

INTERNATIONAL
STANDARD

ISO
14224

Third edition
2016-09-15

Corrected version
2016-10-01

**Petroleum, petrochemical and
natural gas industries — Collection
and exchange of reliability and
maintenance data for equipment**

*Industries du pétrole, de la pétrochimie et du gaz naturel — Collecte
et échange de données de fiabilité et de maintenance des équipements*



Reference number
ISO 14224:2016(E)

© ISO 2016



COPYRIGHT PROTECTED DOCUMENT

© ISO 2016, Published in Switzerland

All rights reserved. Unless otherwise specified, no part of this publication may be reproduced or utilized otherwise in any form or by any means, electronic or mechanical, including photocopying, or posting on the internet or an intranet, without prior written permission. Permission can be requested from either ISO at the address below or ISO's member body in the country of the requester.

ISO copyright office
Ch. de Blandonnet 8 • CP 401
CH-1214 Vernier, Geneva, Switzerland
Tel. +41 22 749 01 11
Fax +41 22 749 09 47
copyright@iso.org
www.iso.org

Contents

Page

Foreword	v
Introduction	vi
1 Scope	1
2 Normative references	2
3 Terms and definitions	2
4 Abbreviated terms	18
5 Application	20
5.1 Equipment coverage	20
5.2 Time periods	20
5.3 Users of this International Standard	20
5.4 Limitations	21
5.5 Exchange of RM data	22
6 Benefits of RM data collection and exchange	23
7 Quality of data	25
7.1 Obtaining quality data	25
7.1.1 Definition of data quality	25
7.1.2 Planning measures	25
7.1.3 Verification of quality	26
7.1.4 Limitations and problems	27
7.2 Data collection process	27
7.2.1 Data sources	27
7.2.2 Data collection methods	28
7.2.3 Organization and training	28
8 Equipment boundary, taxonomy and time definitions	29
8.1 Boundary description	29
8.2 Taxonomy	30
8.3 Timeline issues	32
8.3.1 Surveillance and operating period	32
8.3.2 Data collection periods	33
8.3.3 Maintenance times	34
9 Recommended data for equipment, failures and maintenance	35
9.1 Data categories	35
9.2 Data format	35
9.3 Database structure	36
9.3.1 Description	36
9.3.2 Logical structure	36
9.3.3 Database architecture	37
9.4 Equipment data	38
9.5 Failure data	40
9.6 Maintenance data	42
9.6.1 General	42
9.6.2 Maintenance categories	42
9.6.3 Reporting maintenance data	43
Annex A (informative) Equipment-class attributes	46
Annex B (normative) Interpretation and notation of failure and maintenance parameters	176
Annex C (informative) Guide to interpretation and calculation of derived reliability and maintenance parameters	205
Annex D (informative) Typical requirements for data	229

Annex E (informative) Key performance indicators (KPIs) and benchmarking	238
Annex F (informative) Classification and definition of safety critical failures	251
Bibliography	260

Foreword

ISO (the International Organization for Standardization) is a worldwide federation of national standards bodies (ISO member bodies). The work of preparing International Standards is normally carried out through ISO technical committees. Each member body interested in a subject for which a technical committee has been established has the right to be represented on that committee. International organizations, governmental and non-governmental, in liaison with ISO, also take part in the work. ISO collaborates closely with the International Electrotechnical Commission (IEC) on all matters of electrotechnical standardization.

The procedures used to develop this document and those intended for its further maintenance are described in the ISO/IEC Directives, Part 1. In particular the different approval criteria needed for the different types of ISO documents should be noted. This document was drafted in accordance with the editorial rules of the ISO/IEC Directives, Part 2. www.iso.org/directives

Attention is drawn to the possibility that some of the elements of this document may be the subject of patent rights. ISO shall not be held responsible for identifying any or all such patent rights. Details of any patent rights identified during the development of the document will be in the Introduction and/or on the ISO list of patent declarations received. www.iso.org/patents

Any trade name used in this document is information given for the convenience of users and does not constitute an endorsement.

For an explanation on the meaning of ISO specific terms and expressions related to conformity assessment, as well as information about ISO's adherence to the WTO principles in the Technical Barriers to Trade (TBT) see the following URL: [Foreword - Supplementary information](#)

The committee responsible for this document is Technical Committee ISO/TC 67, *Materials, equipment and offshore structures for petroleum, petrochemical and natural gas industries*.

This third edition cancels and replaces the second edition (ISO 14224:2006), which has been technically revised. The main changes are:

- Clause 3 — several new definitions;
- Clauses 8 and 9 — changes in some figures and tables;
- Annex A — new equipment classes;
- Annex B — associated new and aligned failure modes;
- Annex C — some changes and new subclauses, e.g. C.3.4 and C.7;
- Annex D — new subclause D.5;
- Annex E — new KPIs;
- Annex F — alignment with ISO/TR 12489:2013.

This corrected version of ISO 14224:2016 incorporates various editorial corrections.

Introduction

This International Standard has been prepared based on the previous edition (ISO 14224:2006), experience gained through its use, and know-how and best practices shared through the international development process.

In the petroleum, petrochemical and natural gas industries, great attention is being paid to safety, availability, reliability and maintainability of equipment. The industry annual cost of equipment unavailability is very large, although many plant owners have improved the availability of their operating facilities by addressing this challenge. A stronger emphasis has recently been put on cost-effective design and maintenance for new plants and existing installations among more industrial parties. In this respect, data on failures, failure mechanisms and maintenance related to these industrial facilities and its operations have become more important. It is necessary that this information is used by, and communicated between, the various parties and its disciplines, within the same company or between companies. Various analysis methodologies are used to estimate the risk of hazards to people and environment, or to analyse plant or system performance. For such analyses to be effective and decisive, equipment reliability and maintenance (RM) data are vital.

These analyses require a clear understanding of the equipment's technical characteristics, its operating and environmental conditions, its potential failures and its maintenance activities. It can be necessary to have data covering several years of operation before sufficient data have been accumulated to give confident analysis results and relevant decision support. It is necessary, therefore, to view data collection as a long-term activity, planned and executed with appropriate goals in mind. At the same time, clarity as to the causes of failures is key to prioritizing and implementing corrective actions that result in sustainable improvements in availability, leading to improved profitability and safety.

Data collection is an investment. Data standardization, when combined with enhanced data-management systems that allow electronic collection and transfer of data, can result in improved quality of data for reliability and maintenance. A cost-effective way of optimizing data requirements is through industry co-operation. To make it possible to collect, exchange and analyse data based on common viewpoints, a standard is required. Standardization of data collection practices facilitates the exchange of information between relevant parties e.g. plants, owners, manufacturers and contractors throughout the world.

Petroleum, petrochemical and natural gas industries — Collection and exchange of reliability and maintenance data for equipment

1 Scope

This International Standard provides a comprehensive basis for the collection of reliability and maintenance (RM) data in a standard format for equipment in all facilities and operations within the petroleum, natural gas and petrochemical industries during the operational life cycle of equipment. It describes data collection principles and associated terms and definitions that constitute a “reliability language” that can be useful for communicating operational experience. The failure modes defined in the normative part of this International Standard can be used as a “reliability thesaurus” for various quantitative as well as qualitative applications. This International Standard also describes data quality control and assurance practices to provide guidance for the user.

Standardization of data collection practices facilitates the exchange of information between parties, e.g. plants, owners, manufacturers and contractors. This International Standard establishes requirements that any in-house or commercially available RM data system is required to meet when designed for RM data exchange. Examples, guidelines and principles for the exchange and merging of such RM data are addressed. This International Standard also provides a framework and guidelines for establishing performance objectives and requirements for equipment reliability and availability performance.

[Annex A](#) contains a summary of equipment that is covered by this International Standard.

This International Standard defines a minimum amount of data that is required to be collected, and it focuses on two main issues:

- data requirements for the categories of data to be collected for use in various analysis methodologies;
- standardized data format to facilitate the exchange of reliability and maintenance data between plants, owners, manufacturers and contractors.

The following main categories of data are to be collected:

- a) equipment data, e.g. equipment taxonomy, equipment attributes;
- b) failure data, e.g. failure cause, failure consequence;
- c) maintenance data, e.g. maintenance action, resources used, maintenance consequence, down time.

NOTE Clause 9 gives further details on data content and data format.

The main areas where such data are used are the following:

- 1) reliability, e.g. failure events and failure mechanisms;
- 2) availability/efficiency, e.g. equipment availability, system availability, plant production availability;
- 3) maintenance, e.g. corrective and preventive maintenance, maintenance plan, maintenance supportability;
- 4) safety and environment, e.g. equipment failures with adverse consequences for safety and/or environment.

This International Standard does not apply to the following:

- i. data on (direct) cost issues;

- ii. data from laboratory testing and manufacturing (e.g. accelerated lifetime testing), see also 5.2;
- iii. complete equipment data sheets (only data seen relevant for assessing the reliability performance are included);
- iv. additional on-service data that an operator, on an individual basis, can consider useful for operation and maintenance;
- v. methods for analysing and applying RM data (however, principles for how to calculate some basic reliability and maintenance parameters are included in the annexes).

2 Normative references

The following documents, in whole or in part, are normatively referenced in this document and are indispensable for its application. For dated references, only the edition cited applies. For undated references, the latest edition of the referenced document (including any amendments) applies.

ISO 20815:2008, *Petroleum, petrochemical and natural gas industries — Production assurance and reliability management*

3 Terms and definitions

For the purposes of this document, the following terms and definitions apply.

NOTE Some derived RM parameters, which can be calculated from collected RM data covered by this International Standard, are contained in Annex C. References to Annex C are given as deemed appropriate.

3.1 active maintenance time

duration of a maintenance action, excluding logistic delay

Note 1 to entry: Technical delays are included in the active maintenance time.

Note 2 to entry: See [Figure 4](#) and Annex C for a more detailed description and interpretation of maintenance times. See also ISO/TR 12489:2013, Figure 5.

Note 3 to entry: A maintenance action can be carried out while the item is performing a required function.

[SOURCE: IEC 60050-192:2015, 192-07-04, modified – Notes 2 and 3 to entry have been added.]

3.2 active repair time

effective time to achieve repair of an item

Note 1 to entry: See also ISO/TR 12489:2013, Figures 5 and 6.

Note 2 to entry: See also definition of “mean active repair time (MART)” in ISO/TR 12489:2013, 3.1.34, that is defined as “expected active repair time”.

3.3 availability

ability to be in a state to perform as required

Note 1 to entry: See Annex C for a more detailed description and interpretation of availability.

Note 2 to entry: Further terms are given in ISO/TR 12489:2013.

[SOURCE: IEC 60050-192:2015, 192-01-23, modified – Notes 1 and 2 to entry have been added.]

3.4 boundary

interface between an item and its surroundings

3.5**common cause failures**

failures of multiple items, which would otherwise be considered independent of one another, resulting from a single cause

Note 1 to entry: Common cause failures can also be common mode failures.

Note 2 to entry: The potential for common cause failures reduces the effectiveness of system redundancy.

Note 3 to entry: It is generally accepted that the failures occur simultaneously or within a short time of each other.

Note 4 to entry: Components that fail due to a shared cause normally fail in the same functional mode. The term common mode is therefore sometimes used. It is, however, not considered to be a precise term for communicating the characteristics that describe a common cause failure.

Note 5 to entry: See also ISO/TR 12489:2013, 3.2.14 and 5.4.2.

Note 6 to entry: See also C.1.6

[SOURCE: IEC 60050-192:2015, 192-03-18, modified – Notes 3-6 to entry have been added.]

3.6**common mode failures**

failures of different items characterized by the same failure mode

Note 1 to entry: Common mode failures can have different causes.

Note 2 to entry: Common mode failures can also be common cause failures (3.5).

Note 3 to entry: The potential for common mode failures reduces the effectiveness of system redundancy.

[SOURCE: IEC 60050-192:2015, 192-03-19, modified]

3.7**condition-based maintenance****CBM**

preventive maintenance based on the assessment of physical condition

Note 1 to entry: The condition assessment can be by operator observation, conducted according to a schedule, or by condition monitoring of system parameters.

[SOURCE: IEC 60050-192:2015, 192-06-07, modified]

3.8**corrective maintenance**

maintenance carried out after fault detection to effect restoration

Note 1 to entry: Corrective maintenance of software invariably involves some modification

Note 2 to entry: See also ISO/TR 12489:2013, Figures 5 and 6, which illustrate terms used for quantifying corrective maintenance.

[SOURCE: IEC 60050-192:2015, 192-06-06, modified – Note 2 to entry has been added.]

3.9**critical failure**

failure of an equipment unit that causes an immediate cessation of the ability to perform a required function

Note 1 to entry: Includes failures requiring immediate action towards cessation of performing the function, even though actual operation can continue for a short period of time. A critical failure results in an unscheduled repair.

Note 2 to entry: See also definition of “critical dangerous failure” and “critical safe failure” in ISO/TR 12489:2013, 3.2.4 and 3.2.7, respectively.

**3.10
cycle**

operation and subsequent release/reset

[SOURCE: IEC 60050-444:2002, 444-02-11]

**3.11
degraded failure**

failure that does not cease the fundamental function(s), but compromises one or several functions

Note 1 to entry: The failure can be gradual, partial or both. The function can be compromised by any combination of reduced, increased or erratic outputs. An immediate repair can normally be delayed but, in time, such failures can develop into a critical failure if corrective actions are not taken.

**3.12
demand**

activation of the function (includes functional, operational and test activation)

Note 1 to entry: See C.1.3 for a more detailed description.

Note 2 to entry: Annex F.3 gives a list of safety critical equipment which are subject to periodic testing.

Note 3 to entry: See also relevant definitions in ISO/TR 12489:2013: “mean time to demand (MTTD)” is defined in 3.1.38, “failure due to demand” is defined in 3.2.13, and “demand mode of operation safety system” is defined in 3.3.1.

**3.13
design life**

planned usage time for the total system

Note 1 to entry: It is important not to confuse design life with the ‘mean time to failure’ (MTTF), which is comprised of several items that might be allowed to fail within the design life of the system as long as repair or replacement is feasible.

[SOURCE: ISO 20815:2008, 3.1.5]

**3.14
detection method**

method or activity by which a failure is discovered

Note 1 to entry: A categorization of detection methods (e.g. periodic testing or continuous condition monitoring) is shown in [Table B.4](#).

**3.15
down state
unavailable state
internally disabled state
internal disabled state**

<of an item> state of being unable to perform as required, due to internal fault, or preventive maintenance

Note 1 to entry: Down state relates to unavailability of the item.

Note 2 to entry: The adjectives “down” or “unavailable” designate an item in a down state.

Note 3 to entry: See also [Table 4](#) and [Figure 4](#).

Note 4 to entry: See also ISO/TR 12489:2013, Figures 5 and 6.

[SOURCE: IEC 60050-192:2015, 192-02-20, modified – Notes 3 and 4 to entry have been added.]

3.16 down time

time interval during which an item is in a down state

Note 1 to entry: The down time includes all the delays between the item failure and the restoration of its service. Down time can be either planned or unplanned (see [Table 4](#)).

Note 2 to entry: Mean downtime is in IEC 60050-192, 192-08-10, defined as the 'expectation of the down time'.

[SOURCE: IEC 60050-192:2015, 192-02-21, modified - Notes 1 and 2 to entry have been added.]

3.17 downstream

business category most commonly used in the petroleum industry to describe post-production processes

EXAMPLE Refining, transportation and marketing of petroleum products

Note 1 to entry: See also A.1.4 for further details.

3.18 equipment class

class of similar type of equipment units (e.g. all pumps)

Note 1 to entry: [Annex A](#) contains equipment-specific data for the equipment covered in this International Standard.

3.19 equipment data

technical, operational and environmental parameters characterizing the design and use of an equipment unit

3.20 equipment type

particular feature of the design which is significantly different from the other design(s) within the same equipment class

3.21 equipment unit

specific equipment within an equipment class as defined by its boundary

Note 1 to entry: Equipment unit is given at level 6 of the equipment taxonomy classification with taxonomic levels shown in [Figure 3](#).

3.22 error

discrepancy between a computed, observed or measured value or condition and the true, specified or theoretically correct value or condition

Note 1 to entry: An error within a system can be caused by failure of one or more of its components, or by the activation of a systematic fault.

Note 2 to entry: An error can be caused by a faulty item, e.g. a computing error made by faulty computer equipment.

Note 3 to entry: In this International Standard, error is also specifically used for software and human errors.

[SOURCE: IEC 60050-192:2015, 192-03-02, modified – Notes 2 and 3 to entry have been added.]

3.23

failure

<of an item> loss of ability to perform as required

Note 1 to entry: A failure of an item is an event that results in a fault of that item: see fault (3.22).

Note 2 to entry: A failure of an item is an event, as distinct from a fault of an item, which is a state [source: ISO/TR 12489:2013].

Note 3 to entry: This concept as defined does not apply to items consisting of software only.

Note 4 to entry: See [Table B.1](#), and also F.2 and F.3.

[SOURCE: IEC 60050-192:2015, 192-03-01, modified – Notes 2 through 4 to entry have been added.]

3.24

failure cause

root cause

set of circumstances that leads to failure

Note 1 to entry: A failure cause can originate during specification, design, manufacture, installation, operation or maintenance of an item.

Note 2 to entry: See also B.2.3 and [Table B.3](#), which define failure causes for all equipment classes.

[SOURCE: IEC 60050-192:2015, 192-03-11, modified – Note 2 to entry has been added.]

3.25

failure data

data characterizing the occurrence of a failure event

Note 1 to entry: See also [Table 6](#).

3.26

failure due to demand

failure occurring on demand

Note 1 to entry: See further details in ISO/TR 12489:2013, 3.2.13.

[SOURCE: ISO/TR 12489:2013, modified – Note 1 to entry has been added.]

3.27

failure frequency

unconditional failure intensity; conditional probability per unit of time that the item fails between t and $t + dt$, provided that it was working at time 0

Note 1 to entry: Another term used for failure frequency is “rate of occurrence”.

Note 2 to entry: See also ISO/TR 12489:2013, 3.1.22 and 3.1.23.

[SOURCE: ISO/TR 12489:2013, modified – Notes 1 and 2 to entry have been added.]

3.28

failure impact

effect of a failure on an equipment’s function(s) or on the plant

Note 1 to entry: On the equipment level, failure impact can be classified in three classes (critical, degraded, incipient); see definitions of “critical failure” (3.9), “degraded failure” (3.11) and “incipient failure” (3.40). Classification of failure impact on taxonomy levels 3 to 5 (see [Figure 3](#)) is shown in [Table 3](#).

Note 2 to entry: Classification of failure impact on taxonomy levels 4 and 5 (see [Figure 3](#)) is shown in [Table 3](#). See also C.1.10.

3.29**failure mechanism**

process that leads to failure

Note 1 to entry: The process can be physical, chemical, logical, or a combination thereof.

Note 2 to entry: See also B.2.2 and [Table B.2](#), which define failure causes for all equipment classes.

[SOURCE: IEC 60050-192:2015, 192-03-12, modified – Note 2 to entry has been added.]

3.30**failure mode**

manner in which failure occurs

Note 1 to entry: See also the tables in B.2.6, on the relevant failure modes which defines failure modes to be used for each equipment class

Note 2 to entry: Analysis might require data collection to be established on different taxonomy levels, see [Table 3](#).

[SOURCE: IEC 60050-192:2015, 192-03-17, modified – Notes 1 and 2 to entry have been added.]

3.31**failure on demand**

failure likely to be observed when a demand occurs

Note 1 to entry: Failure on demand includes the failures occurred before the demand and the failures due to the demand.

Note 2 to entry: See also C.6 on testing for hidden failures in safety systems.

Note 3 to entry: See also definition on *failure due to demand* ([3.26](#)).

Note 4 to entry: See ISO/TR 12489:2013, 3.1.15 for definition of the probability of failure on demand (PFD).

Note 5 to entry: Different failure modes are used to reflect failure on demand (see the tables in B.2.6).

[SOURCE: ISO/TR 12489:2013, modified – Notes 1 through 5 to entry have been added.]

3.32**failure rate**

conditional probability per unit of time that the item fails between t and $t + dt$, provided that it has been working over $[0, t]$

Note 1 to entry: See also definition of failure rate in ISO/TR 12489:2013, 3.1.18.

Note 2 to entry: See also definition of failure rate in IEC 60050-192:2015, 192-05-06 (instantaneous failure rate).

[SOURCE: ISO/TR 12489:2013, modified – Notes 1 and 2 to entry have been added.]

3.33**fault**

inability to perform as required, due to an internal state

Note 1 to entry: A fault of an item results from a failure, either of the item itself, or from a deficiency in an earlier stage of the life cycle, such as specification, design, manufacture or maintenance. See *latent fault* ([3.44](#)).

Note 2 to entry: A fault is often a result of a failure of the item itself but the state can exist without a failure (see ISO 20815:2008, 3.1.14).

Note 3 to entry: See also ISO/TR 12489:2013, 3.2.2.

[SOURCE: IEC 60050-192:2015, 192-04-01, modified – Notes 2 and 3 to entry have been added.]

3.34

generic reliability data

reliability data covering families of similar equipment

Note 1 to entry: See Annex D.5 and Table D.5.

3.35

hidden failure

failure that is not immediately evident to operations and maintenance personnel

Note 1 to entry: Equipment failures that occurred at an earlier point of time, but were first observed at demand, fall into this category. Such failures are first revealed when the relevant functionality is tested (activated).

Note 2 to entry: See definition with notes to entry in ISO/TR 12489:2013, 3.2.11.

Note 3 to entry: See also *latent fault* (3.44).

3.36

human error

discrepancy between the human action taken or omitted and that intended

EXAMPLE Performing an incorrect action; omitting a required action.

Note 1 to entry: Discrepancy with intention is considered essential in determining human error (see [303]).

Note 2 to entry: The term “human error” is often attributed in hindsight to a human decision, action or inaction considered to be an initiator or contributory cause of a negative outcome such as loss or harm.

Note 3 to entry: In human reliability assessment human error is defined as any member of a set of human actions or activities that exceeds some limit of acceptability, this being an out of tolerance action or failure to act where the limits of performance are defined by the system (see [298]).

Note 4 to entry: See also IEC 62508:2010 for further details.

Note 5 to entry: See also ISO/TR 12489:2013, 5.5.2.

[SOURCE: IEC 60050-192:2015, 192-03-14, modified – Notes 1 through 5 to entry have been added.]

3.37

human fatigue

loss of physiological and psychological function as a result of extended wakefulness, heavy work, excessive stimulation, illness or stress

Note 1 to entry: Human fatigue can be related to some of the failure causes in [Table B.3](#), e.g. operating error.

[SOURCE: Moore-Ede M.:2009, modified – Note 1 to entry has been added.]

3.38

idle state

non-operating up state during non-required time

Note 1 to entry: The adjective “idle” designates an item in an idle state.

Note 2 to entry: In some applications, an item in an idle state has some functioning subsystems, and is therefore considered to be operating.

Note 3 to entry: The non-operating time comprises the idle time, the stand-by time and the externally disabled time

[SOURCE: IEC 60050-192:2015, 192-02-14, modified – Note 3 to entry has been added.]

3.39**idle time**

time interval for which the item is in an idle state

[SOURCE: IEC 60050-192:2015, 192-02-15]

3.40**incipient failure**

imperfection in the state or condition of an item so that a degraded or critical failure might (or might not) eventually be the expected result if corrective actions are not taken

Note 1 to entry: The recording of incipient failure requires some criteria for when a fault of this nature requires registration as opposed to a state/condition where no corrective actions are required.

3.41**indenture level**

level of subdivision of an item from the point of view of maintenance action

3.42**integrity**

ability of a barrier to function as required when needed

Note 1 to entry: See 3.1.2 in ISO/TR 12489:2013 for definition of safety integrity.

Note 2 to entry: There are different definitions of integrity: plant, asset, system, pipeline, well (see ISO 16530-1:—, 2.73), mechanical, safety (see ISO/TR 12489:2013, 3.1.2), structural and technical.

3.43**item**

subject being considered

Note 1 to entry: The item can be an individual part, component, device, functional unit, equipment, subsystem, or system.

Note 2 to entry: The item may consist of hardware, software, people or any combination thereof.

Note 3 to entry: In this International Standard, the common term “item” is used on all taxonomy levels 6 to 9 in [Figure 3](#). See also 3.30, which defines a specific item level.

[SOURCE: IEC 60050-192:2015, 192-01-01, modified – Note 3 to entry has been added.]

3.44**latent fault****undetected fault**

<of an item> fault that has not become apparent

Note 1 to entry: A latent fault can eventually be revealed by preventive maintenance or by a system failure.

[SOURCE: IEC 60050-192:2015, 192-04-08, modified]

3.45**life cycle**

series of identifiable stages through which an item goes, from its conception to disposal

Note 1 to entry: See 5.2 for the purpose of data collection.

Note 2 to entry: See also ISO 20815:2008, Table 2 for the purpose of production assurance.

[SOURCE: IEC 60050-192:2015, 192-01-09, modified – Notes 1-2 to entry have been added.]

3.46

logistic delay

delay, excluding administrative delay, incurred for the provision of resources needed for a maintenance action to proceed or continue

Note 1 to entry: Logistic delays can be due to, for example, travelling to unattended installations, pending arrival of spare parts, specialists, test equipment and information, and delays due to unsuitable environmental conditions (e.g. waiting on weather).

Note 2 to entry: See also ISO/TR 12489:2013, Figure 5.

[SOURCE: IEC 60050-192:2015, 192-07-13, modified – Notes 1 and 2 to entry have been added.]

3.47

maintainability

<of an item> ability to be retained in, or restored to a state to perform as required, under given conditions of use and maintenance

Note 1 to entry: Given conditions would include aspects that affect maintainability, such as: location for maintenance, accessibility, maintenance procedures and maintenance resources.

Note 2 to entry: Maintainability can be quantified using appropriate measures. See IEC 60050-192:2015, 192-07-Maintainability and maintenance support: measures.

Note 3 to entry: See Annex C for a more detailed definition and interpretation of maintainability.

[SOURCE: IEC 60050-192:2015, 192-01-27, modified – Note 3 to entry has been added.]

3.48

maintainable item

item that constitutes a part or an assembly of parts that is normally the lowest level in the equipment hierarchy during maintenance

3.49

maintenance

combination of all technical and management actions intended to retain an item in, or restore it to, a state in which it can perform as required

Note 1 to entry: See also definition of “maintenance” in ISO/TR 12489:2013, 3.4.1.

[SOURCE: IEC 60050-192:2015, 192-06-01, modified – Note 1 to entry has been added.]

3.50

maintenance concept

definition of the maintenance objectives, line of maintenance, indenture levels, maintenance levels, maintenance support, and their interrelationships

Note 1 to entry: The maintenance policy provides the basis for maintenance planning, determining supportability requirements, and developing logistic support.

Note 2 to entry: See also ISO/TR 12489:2013, 3.4.2.

[SOURCE: IEC 60050-192:2015, 192-06-02, modified – Note 2 to entry has been added.]

3.51

maintenance data

data characterizing the maintenance action planned or done

Note 1 to entry: Refers to the type of data dealt with in this International Standard.

Note 2 to entry: See also 9.6.3, [Table 8](#).

Note 3 to entry: See also ISO/TR 12489:2013, Clause 3.

3.52**maintenance impact**

effect of the maintenance on the plant or equipment's function(s)

Note 1 to entry: On the equipment level, two classes of impact are defined: critical and non-critical. On plant level, three classes are defined: total, partial or zero impact.

3.53**maintenance man-hours**

accumulated duration of the individual maintenance times used by all maintenance personnel for a given type of maintenance action or over a given time interval

Note 1 to entry: Maintenance man-hours are expressed in units of hours.

Note 2 to entry: As several people can work at the same time, man-hours are not directly related to other parameters like the "mean time to repair" and "mean down time".

3.54**maintenance plan**

structured and documented set of tasks that include the activities, procedures, resources and the time scale required to carry out maintenance

Note 1 to entry: See also ISO/TR 12489:2013, 3.4.6.

[SOURCE: EN 13306:2010, 2.5, modified – Note 1 to entry has been added.]

3.55**maintenance record**

part of maintenance documentation that contains all failures, faults and maintenance information relating to an item

Note 1 to entry: This record can also include maintenance costs, item availability or up time and any other data where relevant.

3.56**maintenance supportability
supportability**

<of an item> ability to be supported to sustain the required availability with a defined operational profile and given logistic and maintenance resources

Note 1 to entry: Supportability of an item results from the inherent maintainability (3.47), combined with factors external to the item that affect the relative ease of providing the required maintenance and logistic support.

Note 2 to entry: See Annex C for further details regarding the interpretation of maintainability.

[SOURCE: IEC 60050-192:2015, 192-01-31, modified – Note 2 to entry has been added.]

3.57**mean cycles to failure****MCTF**

expected number of cycles before the item fails

Note 1 to entry: See also C.3.4.

Note 2 to entry: Refer to definition of *cycle* (3.10).

3.58**mean number of cycles**

expected number of cycles per time unit

Note 1 to entry: See also C.3.4.

Note 2 to entry: Refer to definition of *cycle* (3.10).

3.59

mean active repair time

MART

expected active repair time

Note 1 to entry: The MART is the expected effective time to repair.

Note 2 to entry: See also definition of active repair time

[SOURCE: ISO/TR 12489:2013, 3.1.34, modified – Note 2 to entry has been added.]

3.60

mean elapsed time between failures

METBF

expected elapsed time between successive failures of a repairable item

Note 1 to entry: See further details in ISO/TR 12489:2013, 3.1.30.

Note 2 to entry: IEC 60050-192:2015, 192-05-13 defines mean operating time between failures (abbreviated by MTBF or MOTBF) as “expectation of the duration of the operating time between failures”.

Note 3 to entry: See also Annex C.

3.61

mean overall repairing time

MRT

expected time to achieve the following actions:

- the time spent before starting the repair; and,
- the effective time to repair; and,
- the time before the item is made available to be put back into operation

Note 1 to entry: See ISO/TR 12489:2013, Figures 5 to 7.

[SOURCE: ISO/TR 12489:2013, 3.1.33]

3.62

mean time to failure

MTTF

expected time before the item fails

Note 1 to entry: See further details in ISO/TR 12489:2013, 3.1.29.

Note 2 to entry: IEC 60050-192:2015, 192-05-11, defines MTTF as “expectation of the operating time to failure”.

Note 3 to entry: See also Annex C.

[SOURCE: ISO/TR 12489:2013, 3.1.29, modified – Notes 1 through 3 to entry have been added.]

3.63

mean time to repair

MTTR

expected time to achieve the repair of a failed item

Note 1 to entry: See further details in ISO/TR 12489:2013, 3.1.31.

Note 2 to entry: IEC 60050-192:2015 defines the term as “expectation of the time to restoration”.

Note 3 to entry: See also definition of ‘mean time to restoration’ in ISO/TR 12489:2013, 3.1.32.

Note 4 to entry: In actual life the detection time is either 0 (immediately revealed failures) or unknown (failures detected by tests). Only MRT and MART can be collected.

Note 5 to entry: See also C.5.5.2.

3.64

mean time to restoration

MTTRes

expected time to achieve the following actions:

- a) the time to detect the failure; and,
- b) the time spent before starting the repair; and,
- c) the effective time to repair; and,
- d) the time before the component is made available to be put back into operation

Note 1 to entry: See further details in ISO/TR 12489:2013, 3.1.32.

Note 2 to entry: See also ISO/TR 12489:2013, Figures 5 to 7.

Note 3 to entry: See also definition of “mean overall repairing time” and “mean active repair time” in ISO/TR 12489:2013, 3.1.33 and 3.1.34, respectively.

Note 4 to entry: Mean time to restoration is abbreviated as MTTR in IEC 60050-192:2015, 192-07-23.

[SOURCE: ISO/TR 12489:2013, 3.1.32, modified – Notes 1 through 4 to entry have been added.]

3.65

midstream

business category involving the processing, storage and transportation sectors of the petroleum industry

EXAMPLE Transportation pipelines, terminals, gas processing and treatment, LNG, LPG and GTL.

Note 1 to entry: See also A.1.4 for further details.

3.66

mobilization time

time to get all necessary resources available to execute maintenance

Note 1 to entry: Time spent before starting the maintenance is dependent on access to resources e.g. spare parts, tools, personnel, subsea intervention and support vessels.

Note 2 to entry: See also ISO/TR 12489:2013, Figure 5 and Figure 7.

3.67

modification

combination of all technical and administrative actions intended to change an item

Note 1 to entry: Modification is not normally a part of maintenance, but is frequently performed by maintenance personnel.

Note 2 to entry: Care is needed in the collection and analysis of RM data to distinguish between maintenance due to failures and maintenance due to equipment modification.

Note 3 to entry: See also [Table B.5](#).

3.68

non-critical failure

failure of an equipment unit that does not cause an immediate cessation of the ability to perform its required function

Note 1 to entry: Non-critical failures can be categorized as “degraded” or “incipient” (see separate definitions on degraded failure and incipient failure).

ISO 14224:2016(E)

Note 2 to entry: The term “critical” does not have the same meaning in ISO/TR 12489:2013 as in this International Standard; see further details in F.4.1.

3.69

operating state

<of an item> state of performing as required

Note 1 to entry: See also [Table 4](#).

Note 2 to entry: In some applications, an item in an idle state is considered to be operating.

[SOURCE: IEC 60050-192:2015, 192-02-04, modified – Note 1 to entry has been added.]

3.70

operating time

time interval during which an item is in an operating state

Note 1 to entry: The duration of operating time can be expressed in units appropriate to the item concerned, e.g. calendar time, operating cycles, distance covered, and the units should always be clearly stated.

Note 2 to entry: Operating time includes actual operation of the equipment or the equipment being available for performing its required function.

Note 3 to entry: See also [Table 4](#).

Note 4 to entry: The point in time of start-up time can differentiate depending on item subject to data collection, and could start from time of installation, time of commissioning, or time of start of service/production/injection.

[SOURCE: IEC 60050-192:2015, 192-02-05, modified – Note 1 to entry has been amended and notes 2 through 4 to entry have been added.]

3.71

opportunity maintenance

maintenance of an item that is deferred or advanced in time and is performed when an unplanned opportunity becomes available

3.72

performance objective

indicative level for the desired performance

Note 1 to entry: See further details in ISO 20815:2008, 3.1.32 and Annex F.

[SOURCE: ISO 20815:2008, 3.1.32, modified – Note 1 to entry has been added.]

3.73

performance requirement

required minimum level for the performance of a system

Note 1 to entry: Requirements are normally quantitative but can also be qualitative.

[SOURCE: ISO 20815:2008, 3.1.33, modified]

3.74

periodic test

proof test

planned operation performed at constant time intervals in order to detect the potential hidden failures which can have occurred in the meantime

Note 1 to entry: The unsafe hidden failures of a safety system which are not detected by the diagnostic tests can be detected by periodic tests. Such tests are named “proof tests” in the standards dealing with functional safety (e.g. IEC 61508-4:2010, 3.8.5).

Note 2 to entry: See ISO/TR 12489:2013, 3.4.8, 3.4.9 and 3.4.10 for further details.

[SOURCE: ISO/TR 12489:2013, 3.4.8, modified – Note 2 to entry has been added.]

3.75

petrochemical

business category producing chemicals derived from petroleum and used as feedstock for the manufacture of a variety of plastics and other related products

EXAMPLE Methanol and polypropylene.

Note 1 to entry: See A.1.4 for further details.

3.76

planned maintenance

scheduled maintenance

planned preventive maintenance

maintenance carried out in accordance with a specified time schedule

Note 1 to entry: Scheduled maintenance can identify the need for some corrective maintenance action.

[SOURCE: IEC 60050-192:2015, 192-06-12, modified]

3.77

predictive maintenance

PdM

maintenance based on the prediction of the future condition of an item estimated or calculated from a defined set of historic data and known future operational parameters

Note 1 to entry: See 9.6, [Table B.4](#) and [B.5](#), and also Table E.3.

3.78

preventive maintenance

PM

maintenance carried out to mitigate degradation and reduce the probability of failure

Note 1 to entry: See also condition-based maintenance, and planned (scheduled) maintenance.

[SOURCE: IEC 60050-192:2015, 192-06-05]

3.79

random failure

failure, occurring in a random way

[SOURCE: ISO/TR 12489:2013]

3.80

redundancy

existence of more than one means for performing a required function of an item

Note 1 to entry: See C.1.2 for further details, where passive (cold), active (hot) standby and mixed redundancy are described.

Note 2 to entry: Redundancy in IEC 61508 is called “fault tolerance”.

Note 3 to entry: IEC 60050-192:2015, 192-10-02 defines redundancy as “provision of more than one means for performing a function”.

3.81

reliability

ability of an item to perform a required function under given conditions for a given time interval

Note 1 to entry: The term “reliability” is also used as a measure of reliability performance and can also be defined as a probability; see ISO/TR 12489:2013, 3.1.8.

ISO 14224:2016(E)

Note 2 to entry: See also Annex C.

Note 3 to entry: IEC 60050-192:2015, 192-01-24 defines reliability as “ability to perform as required, without failure, for a given time interval, under given conditions”.

Note 4 to entry: The examples of equipment specific data in [Annex A](#) list technical and operational conditions that can cause differences in equipment reliability performance.

3.82

reliability data

data for reliability, maintainability and maintenance support performance

[SOURCE: ISO 20815:2008, 3.1.42]

3.83

required function

function or combination of functions of an item that is considered necessary to provide a given service

3.84

safety critical equipment

equipment and items of permanent, temporary and portable equipment playing an important role in safety systems/functions

3.85

safety critical failure

critical dangerous failures that are undetected

EXAMPLE Failures revealed by periodic tests.

Note 1 to entry: Critical dangerous failures are in ISO/TR 12489:2013, 3.2.4 defined as “dangerous failure leading to the complete inhibition of the safety action (i.e., leading to a dangerous situation for the protected system)”.

Note 2 to entry: See also Annex F, and specifically F.4.1. regarding the indicator “failure fraction”.

[SOURCE: ISO/TR 12489:2013, notes 1 and 2 to entry have been added.]

3.86

safety system

system which is used to implement one or more safety functions

Note 1 to entry: Safety function is in ISO/TR 12489:2013, 3.1.6 defined as “function which is intended to achieve or maintain a safe state, in respect of a specific hazardous event”.

Note 2 to entry: Systems with safety functions are defined in ISO/TR 12489:2013, Annex A. These systems are also cross-related in [Table A.3](#).

[SOURCE: ISO/TR 12489:2013, 3.1.7, modified – Notes 1 and 2 to entry have been added.]

3.87

software error

erroneous result produced by the use of software product

EXAMPLE Bad code in a computer program resulting in an error.

Note 1 to entry: See [Table B.2](#) for list of relevant equipment failure mechanisms.

Note 2 to entry: See also ISO/TR 12489:2013, B.3, and Note 5 to entry 3.2.17 (Systematic failure) in ISO/TR 12489:2013.

Note 3 to entry: See also definition of “error” (3.22).

3.88**subunit**

assembly of items that provides a specific function that is required for the equipment unit within the main boundary to achieve its intended performance

3.89**surveillance period**

interval of time (calendar time) between the start date and end date of RM data collection

Note 1 to entry: See Annex C for further details.

Note 2 to entry: Surveillance time in data collection is a part of the total accumulated operating time (see definition of operating time).

3.90**systematic failure**

failure that consistently occurs under particular conditions of handling, storage or use

Note 1 to entry: See also Annex F.

Note 2 to entry: See also further details in ISO/TR 12489:2013, 3.2.17.

Note 3 to entry: Reliability data covers random and systematic failures as described in ISO/TR 12489:2013, Figure B.5.

[SOURCE: ISO/TR 12489:2013, 3.2.17, modified – Notes to entry 1 to 3 have been added.]

3.91**tag number**

unique code that identifies the equipment function and its physical location

Note 1 to entry: See Annex C for more detailed definitions and interpretations.

Note 2 to entry: Normally includes the system for which it belongs. The systems covered are shown in [Table A.3](#).

Note 3 to entry: Also entitled “functional location” in some CMMIS.

Note 4 to entry: The equipment is allocated to a tag for only so long as it occupies that function and location. See also footnote b in [Table 5](#).

3.92**taxonomy**

systematic classification of items into generic groups based on factors possibly common to several of the items

3.93**trip**

shutdown of machinery from normal operating condition to full stop

Note 1 to entry: Trip: The shutdown is activated automatically by the control/monitoring system:

- real trip The shutdown is effectuated as a result of a monitored (or calculated) value in the control system exceeding a pre-set limit;
- spurious trip Unexpected shutdown resulting from failure(s) in the control/monitoring system or error(s) imposed on the control/monitoring system originating from the environment or people.

Note 2 to entry: See also ISO/TR 12489:2013, 3.4.14.

3.94
turnaround
revision shutdown

planned event wherein an entire process unit is taken off stream for revamp or renewal

Note 1 to entry: See also ISO 20815:2008, Table G.1.

3.95
uncertainty

<of a quantity> inability to determine accurately what is or will be the true value of a quantity

Note 1 to entry: Uncertainty can have different meanings within reliability data collection and exchange. It can be used as a measure of variability within a population, which is a type of uncertainty often referred to as stochastic (or aleatory) uncertainty. Uncertainty can also have a subjective meaning (epistemic uncertainties).

3.96
up state
available state

<of an item> state of being able to perform as required

Note 1 to entry: Up state relates to the availability performance of the item.

Note 2 to entry: See also ISO/TR 12489:2013, Figure 5.

[SOURCE: IEC 60050-192:2015, 192-02-01, modified – Notes 1 and 2 to entry have been added.]

3.97
up time

time interval during which an item is in an up state

Note 1 to entry: See also ISO/TR 12489:2013, Figure 3.

Note 2 to entry: Mean up time is defined in IEC 60050-192:2015 as “expectation of the up time”.

3.98
upstream

business category of the petroleum industry involving exploration and production

EXAMPLE Offshore oil/gas production facility, drilling rig, intervention vessel.

Note 1 to entry: See also A.1.4 for further details.

4 Abbreviated terms

NOTE Some specific abbreviations used for equipment types (e.g. BOP) and units (e.g. kW) are not included in this clause, but covered within each clause/sub-clause where they are used. There are also some abbreviations used in the document (see e.g. Table D.1), which are not included in this clause.

CAPEX	capital expenditure
CBM	condition-based maintenance
CDF	cumulative distribution function
CM	condition monitoring
CMMIS	computerized maintenance-management information system
DHSV	downhole safety valve
ESD	emergency shutdown

FTA	fault tree analysis
FMECA	failure mode, effect and criticality analysis
HIPPS	high integrity pressure protection system
KPI	key performance indicators
LCC	life cycle cost
LEL	lower explosive limit
MART	mean active repair time
MCTF	mean cycles to failure
MEG	monoethylene glycol
MI	maintainable item
METBF	mean elapsed time between failures
MTTF	mean time to failure
MTTR	mean time to repair
MTTRes	mean time to restoration
MUT	mean up time
MDT	mean down time
MRT	mean overall repairing time
NCR	non-compliance reporting
NDT	non-destructive testing
OPEX	operational expenditure
PdM	predictive maintenance
PM	preventive maintenance
PFD	probability of failure on demand
P&ID	pipng and instrumentation diagram
PSD	process shutdown
PSV	pressure safety valve
QA	quality assurance
QN	quality notification
QRA	quantitative risk assessment
RAM(S)	reliability, availability, maintainability (and safety)
RBI	risk-based inspection
RCM	reliability-centred maintenance

ISO 14224:2016(E)

RM	reliability and maintenance
SCSSV	surface-controlled subsurface safety valve
SIS	safety instrumented system
SIF	safety instrumented function
SIL	safety integrity level
SSIV	subsea isolation valve
TEG	triethylene glycol
TTF	time to failure
TTR	time to repair
WO	work order

5 Application

5.1 Equipment coverage

This International Standard is applicable to equipment types used in the petroleum, natural gas and petrochemical industry including, but not limited to, equipment categories such as process equipment and piping, safety equipment, subsea equipment, pipeline systems, loading/unloading equipment, downhole well equipment and drilling equipment. The equipment can be permanently installed at the facilities or used in conjunction with installation, maintenance or modification phases. The principles of this International Standard can also be relevant for the pre-production phases, e.g. how experience is gained and systematized during technology qualification, fabrication and associated testing (QN, NCR, etc.).

[Annex A](#) contains examples of how this International Standard should be used for specific equipment types. The users are expected to define taxonomies for additional equipment classes as needed based on the principles given by this International Standard.

Some principles for RM data collection at equipment level can be applied for monitoring and analysing performance at plant and system levels constituted by various equipment classes. However, facility- and plant-performance monitoring also requires other types of data not covered by this International Standard.

5.2 Time periods

This International Standard is applicable to data collected during the operational life cycle of equipment, including installation, start-up, operation, maintenance and modification. Laboratory testing, manufacturing and fabrication phases are not specifically addressed in this International Standard. Many of the principles in this standard can however be used by equipment manufacturer to collect and systematize failures occurring on equipment during fabrication and detected during acceptance testing, e.g. for non-compliance reporting (NCR). In addition, it is emphasized that analysis of relevant historic RM data shall be used in the dimensioning of such testing prior to operation. Technology qualification and development require also, and benefit from, past reliability knowledge to reveal potential improvement areas (see 8.3).

5.3 Users of this International Standard

This International Standard is intended for users such as the following.

Installation/plant/facility:	Operating facility, e.g. maintenance and engineering personnel logging equipment failures or recording maintenance events into facility information management systems.
Owner/operator/company:	Reliability staff or others creating (generic) equipment reliability databases for equipment located in company facilities; reliability engineers requiring data or maintenance engineers preparing maintenance plans. This International Standard provides a format for analysing any RM data element as appropriate associated with an analysis (as described in Annex D); e.g. root-cause analysis, analysis of historic performance, prediction of future performance, use in a design process, etc.
Industry:	Groups or companies exchanging equipment RM data or joint industry reliability database project co-operation. Improved communication of equipment reliability performance requires the principles in this International Standard to be adhered to (as a “reliability language”).
Manufacturers/designers:	Use of RM data to improve equipment designs and learn from past experience.
Authorities/regulatory bodies:	A format for communicating any RM data on an individual event basis or as otherwise required from the operating company. This International Standard is, for example, vital for authorities addressing safety equipment reliability.
Consultant/contractor:	A format and quality standard for data collection projects and analyses of safety, reliability or maintenance aspects commonly performed by contractors/consultants for the asset owners (e.g. oil companies).

While others, such as developers of computer-maintenance-management software, can find this International Standard to be useful, the primary users are expected to be owners and/or operators who should find the data to be collected readily available within their operating facilities.

5.4 Limitations

Through analysis of data, RM parameters can be determined for use in design, operation and maintenance. This International Standard does not provide detailed descriptions of methods for analysing data. However, it does give recommendations for defining and calculating some of the vital RM parameters (Annex C) and reviews the purposes and benefits of some analytical methodologies for which data can be used. Such analytical methodologies and application areas can be found in other International Standards, and relevant International Standards have been exploited for the purpose of identifying and co-ordinating the RM data requirements (see Annex D).

Although cost data are important in establishing priorities for improvement opportunities and are frequently included in the analysis of reliability performance, cost data (parameters) are not specifically included in this International Standard. Most facilities track the costs of maintenance (man-hours), equipment replacements, capital improvements, business interruption and environmental events. These data may be maintained in the computerized maintenance management information system (CMMIS). When costs are required for setting the analysis of reliability in an economic perspective or performing calculation of life cycle costing, the user should obtain that information from the appropriate sources within the operating facility or company.

Due to the variety of uses for RM data, requirements for data in a data collection programme should be adapted to the expected application(s). Credible analysis results are directly related to the quality of the data collected. While this International Standard does not specify detailed quality measures, data quality control and assurance practices are outlined to provide guidance for the user.

The technical information gathered to describe the equipment and its location within a plant, facility or system is, in this International Standard, not meant to be exhaustive and complete like the overall

plant technical information system, but rather used to identify and explain variables for the purposes of the analytical functions. Use of common technical terms is, however, recommended and linked to life cycle information-system and equipment technical standards. Even though this International Standard describes how to record maintenance activities for the purpose of equipment reliability and availability optimization, this International Standard is not meant to act as a standard to specify in detail how maintenance programmes are documented.

The technical status of equipment and degradation of equipment performance can be recorded through condition-monitoring systems, which requires details beyond the equipment data covered in this International Standard. However, this International Standard contains RM data elements that can be used in such condition-monitoring systems.

This International Standard is not meant to be a software specification of such database systems but can, in general, be complied with to facilitate and improve the industry RM data exchange.

5.5 Exchange of RM data

A major objective of this International Standard is to make it possible to exchange RM data in a common format within a company, between companies, within an industrial arena or in the public domain. Measures for ensuring the quality of data are discussed in Clause 7. Some additional aspects to be considered with respect to exchange of RM data are the following.

- Detailed versus processed data: Data can be exchanged on various levels from the actual failure and maintenance records to data on a more aggregated level. For example, if only the number of failures of a certain category is required, it is necessary to exchange only the failure quantity for these failures. This sort of information is commonly given in public data sources (e.g. reliability data books). For exchanging data on the overall performance of a unit or a plant (benchmarking), the so-called key performance indicators (KPI) may be used. Examples of KPIs are given in Annex E.
- Data sensitivity: Some data fields can be of a certain sensitive character and/or possibly be used for purposes for which they were not intended (e.g. to obtain commercial advantages, non-qualified communication of plant/equipment experience). To avoid this, two options can be utilized:
 - “blank” such data;
 - make such data anonymous.

The latter can be achieved by defining some anonymous codes representing the data element where only a few authorized persons know the conversion between the codes and the actual data. This is recommended if these data fields are essential for the data taxonomy.

It is important to recognize the potential commercial sensitivity of exchanging reliability and other performance data. Competition law prohibits “collective boycott” agreements or arrangements between competitors where competitors agree not to deal with certain suppliers/contractors. A benchmarking study where competitors exchange information so that suppliers/contractors can be “ranked” incurs a real risk that the parties to the benchmarking study will arrive at a common conclusion not to use particular suppliers/contractors and this should be avoided. Collective boycott arrangements are violations of competition law and can leave individuals and companies exposed to criminal actions.

It is necessary, therefore, that any exchange complies with the national and international laws governing anti-competitive practices. Hence, it is recommended that prior to embarking upon such an exercise, clarification of the local guidelines is sought to avoid possible infringement.

- Data security: Systematized operational-equipment performance (i.e. quality RM data that have a cost to obtain) is an asset generally of great value, and data not open to the public domain shall be treated with appropriate security measures to avoid misuse and not affect the reputation of associated parties. This relates to storage of data (e.g. safe location), transmission of data (e.g. Internet), access to data for authorized users (e.g. password), etc.

- Value of data: In some cases, it is useful to define a “value measure” for an amount of reliability data. This can be the case in joint industry projects where several contributors are supposed to contribute with an equal “value” of data. Two approaches may be used:
 - calculating the actual cost of collecting the data;
 - value the data by combining the population with aggregated surveillance time.

6 Benefits of RM data collection and exchange

Although many plant owners have improved the availability of their operating facilities, lost production and maintenance costs from poor equipment reliability still represent a high annual industrial cost. Even though most failure events are not catastrophic, increased clarity as to the causes of failure events is key to prioritizing and implementing corrective maintenance actions. This results in sustainable improvements in reliability, leading to improved profitability and safety.

Benefits of reliability data analysis are wide-ranging, including the opportunity to optimize the timing of equipment overhauls and inspections, the content of maintenance procedures, as well as the life cycle costing of sparing and upgrade programmes in operating facilities world-wide. Other benefits resulting from the collection and analysis of RM data include improvements in decision-making, reductions in catastrophic failures, reduced environmental impacts, more effective benchmarking and trending of performance, and increased process unit availability. The data collection and exchange principles outlined in this International Standard require the production assurance given in ISO 20815:2008, Table 2 (e.g. “performance data tracking and analysis”).

Improvement of equipment reliability is dependent on experiences from real-life usage. The collection, analysis and feedback of performance data to equipment designers and manufacturers are, therefore, paramount. Also, when purchasing new equipment, RM data are key parameters to take into account.

In order to merge data from several equipment units, plants or across an industry arena, it is required that parties agree on what data are useful to collect and exchange and that those data are contained in a compatible format.

Recently, several nations with oil and gas industries have issued regulations requiring the companies to have a system for the collection, analysis and implementation of corrective and preventive actions, including improvement of systems and equipment. Some of these regulations refer to International Standards, including this International Standard.

Collecting RM data is costly and therefore it is necessary that this effort be balanced against the intended use and benefits. Commonly one would select equipment for RM data collection where the consequences of failures have an impact on safety, production, environment or high repair/replacement cost as indicated below.

A typical feedback loop for potential uses of data and describing a continuous improvement process is shown in [Figure 1](#).

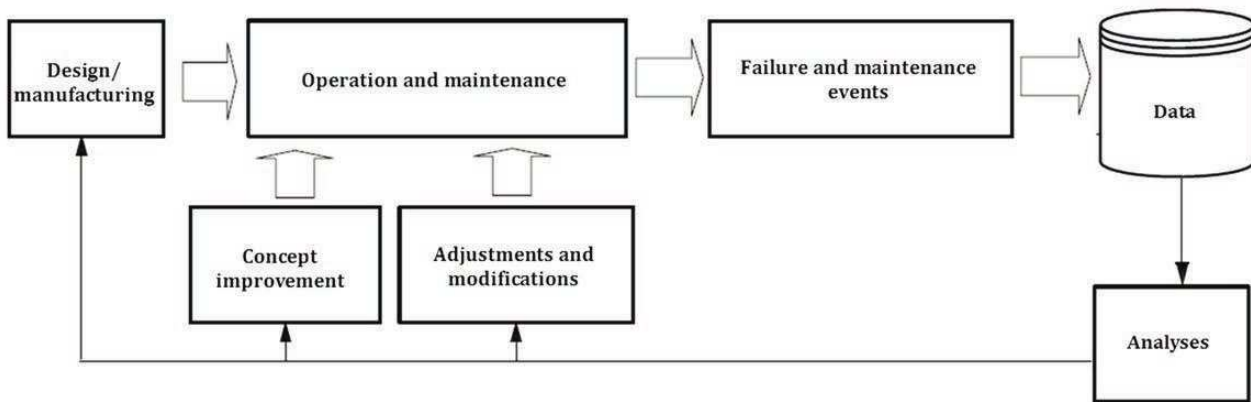

Figure 1 — Typical feedback of analysis from collected reliability and maintenance data

Industry and business value elements of utilizing this International Standard are summarised below:

- economic aspects:
 - cost-effective design to optimize CAPEX,
 - cost-effective operation to optimize OPEX,
 - improved profitability (reduced revenue loss),
 - LCC/whole-life management,
 - reduced cost of insurance;
- general aspects:
 - “being able to operate” (operatorship license),
 - life extension of capital equipment,
 - improved product quality,
 - better (data-based) equipment purchase,
 - better resource planning;
- safety and environmental aspects:
 - improved personnel safety,
 - reduced catastrophic failures,
 - reduced environmental impact,
 - improvement of safety procedures and regulations (e.g. extend test interval based on RM performance),
 - compliance with authority requirements;
- analytical:
 - higher-quality data,
 - larger population of data,
 - improved decision-making,

- reduced uncertainty in decision-making,
- qualified benchmarking,
- exchange of experience in industrial collaboration,
- creation of a common “reliability” language (understanding, various disciplines),
- verification of analysis techniques,
- better predictability,
- basis for a risk-based inspection and reliability-availability-maintainability studies.

7 Quality of data

7.1 Obtaining quality data

7.1.1 Definition of data quality

Confidence in the collected RM data, and hence any analysis, is strongly dependent on the quality of the data collected. High-quality data are characterized by the following:

- a) completeness of data in relation to specification;
- b) compliance with definitions of reliability parameters, data types and formats;
- c) accurate input, transfer, handling and storage of data (manually or electronic);
- d) sufficient population and adequate surveillance period to give statistical confidence;
- e) relevance of the data to the need of the users.

7.1.2 Planning measures

The following measures shall be emphasized before the data collection process starts.

- Define the objective for collecting the data in order to collect data relevant for the intended use. Examples of analyses where such data may be used are quantitative risk analysis (QRA); reliability, availability and maintainability analysis (RAM); reliability-centred maintenance (RCM); life cycle cost (LCC); safety integrity level (SIL) analysis. (See also Annex D.)
- Investigate the source(s) of the data to ensure that relevant data of sufficient quality are available. Sources cover inventory/technical equipment information, RM event data and associated plant impacts.
- Define the taxonomical information to be included in the database for each equipment unit (see Clause 8).
- Identify the installation date, population and operating period(s) for the equipment from which data can be collected.
- Define the boundaries for each equipment class, indicating what RM data are to be collected (see Clause 8).
- Apply a uniform definition of failure and a method of classifying failures (see Clause 9).
- Apply a uniform definition of maintenance activities and a method of classifying maintenances (see Clause 9).

- Define the checks used in data quality verification (see 7.1.3 and 7.1.9). At a minimum, the following shall be verified.
 - 1) The origin of the data is documented and traceable.
 - 2) The data originate from similar equipment type, technology and operating conditions.
 - 3) The equipment is relevant for the purpose (e.g. not outdated models).
 - 4) The data comply with definitions and interpretation rules (e.g. definition of failure).
 - 5) Recorded failures are within the defined equipment boundary and surveillance period.
 - 6) The information is consistent (e.g. consistency between failure modes and failure impact).
 - 7) Data are registered in the correct format.
 - 8) Sufficient data are collected to give acceptable statistical confidence, e.g. not biased by outliers. (See recommendations for calculating confidence limits in C.3.2.)
 - 9) Operating and maintenance personnel are consulted to validate the data.
- Define a priority level for the completeness of data by a suitable method. One method of weighting the importance of the different data to be collected is by using three classes of importance in accordance with the following classification:
 - HIGH: compulsory data (coverage \approx 100 %)
 - MEDIUM: highly desirable data (coverage $>$ 85 %)
 - LOW: desirable data (coverage $>$ 50 %)
- Define the level of detail of RM data reported and collected and link it closely to the production and safety importance of the equipment. Base prioritization on safety, production performance and/or other severity measures.
- Prepare a plan for the data collection process (see 7.2), e.g. schedules, milestones, data collection sequence for installations and equipment units, surveillance periods to be covered (see 8.3.1), etc.
- Plan how the data will be assembled and reported and devise a method for transferring the data from the data source to the reliability data bank using any suitable method (see 7.2).
- Train, motivate and organize the data collection personnel, e.g. interpretation of sources, equipment know-how, software tools, involvement of operating personnel and equipment experts, understanding/ experience in analysis application of RM data, etc. Ensure that they have an in-depth understanding of the equipment, its operating conditions, this International Standard and the requirements given for data quality.
- Make a plan for quality assurance of the data collection process and its deliverables. This shall, as a minimum, include procedures for quality control of the data and recording and correcting deviations (see 7.1.3).
- It is recommended to carry out a cost-benefit analysis of the data collection by running a pilot exercise before the main data collection phase is started and to revise the plan if necessary.
- Review the planning measures after a period of using the system (see 7.2.3).

7.1.3 Verification of quality

During and after the data collection exercise, analyse the data to verify consistency, reasonable distributions, proper codes and correct interpretations in accordance with the planning measures (see 7.1.2). This verification-of-quality process shall be documented and may vary depending on whether

the data collection is for a single plant or involves several company or industry facilities. When merging individual databases, it is imperative that each data record has a unique identification.

Assess the quality of data being collected as early as feasible in the data collection process in accordance with the planning measures (see 7.1.2). A suitable procedure is an assessment by the data collector, who shall be provided with guidelines for what quality measures should be focused on in accordance with the planning measures. The main objective of this early assessment is to look for any problems that require the planning measures to be immediately revised to avoid unacceptable data being collected.

Personnel other than those having collected the data shall verify the quality of each individual data record and the overall reliability pattern reflected by the sum of individual events in accordance with the planning measures (see 7.1.2).

7.1.4 Limitations and problems

Some of the problems and limitations to be aware of, when obtaining quality data are summarized in [Table 1](#).

Table 1 — Problems, limitations and storage

Issue	Challenges
Source	The data source can lack the required data and the source information can be spread over several different systems (computers, files, books, drawings). It is recommended to carefully evaluate this aspect in the planning measures (see 7.1.2) in order to assess data quality, collection method and cost.
Interpretation	Commonly, data are compiled from the source into a standardized format (database). In this process, the source data can be interpreted differently by various individuals. Correct definitions, training and quality checks can reduce this problem (see 7.1.2).
Data format	The use of coded fields is fundamental to ensure data collection efficiency and consistency of data entered (e.g. correct coding of a manufacturer). Free text should, however, be included in addition to codes to describe unexpected or unclear situations
Data collection method	Most data needed for this category of data collection are today stored in computerized systems (e.g. CMMIS). By using state-of-the-art conversion algorithms and software, it is possible to transfer data among different computer databases in a (semi-)automated way, thereby saving cost.
Competence and motivation	Data collection in the “normal” manual way can become a repetitive and tedious exercise. Therefore, take care to employ people with sufficient know-how to do the jobs, avoid using personnel with low competence/experience, as data quality can suffer, and find measures to stimulate the RM data collection staff, e.g. by training, doing plant visits and involving them in data analyses and application of results. Other examples are feedback on data collection results, involvement in QA processes, relevant information fields in facility CMMIS to stimulate reporting quality, etc.

7.2 Data collection process

7.2.1 Data sources

The facility CMMIS constitutes the main source of RM data. The quality of the data that can be retrieved from this source is dependent on the way RM data are reported in the first place. Reporting of RM data according to this International Standard shall be allowed for in the facility CMMIS, thereby providing a more consistent and sound basis for transferring RM data to equipment RM databases. Other sources of information can be spread across several different systems (computers, files, books, drawings), for example, feedback on data collection results, involvement in QA processes. Adequate or proper use of information fields in facility CMMIS will stimulate reporting quality, etc.

Such data collection creates reliability data sources for various applications, as classified in Table D.5:

- 1) generic data;
- 2) operator/company specific data;

- 3) manufacturer data;
- 4) expert judgement;
- 5) human error data.

7.2.2 Data collection methods

The typical data collection process consists of compiling data from different sources into one database where the type and the format of the data are pre-defined. The most common method is as follows.

- a) Address all the data sources that are available, and extract the relevant “raw” data into an intermediate storage. If the information is contained in a computerized database, use any suitable methods for extracting the relevant information; viz. extraction of targeted information by specific software methods or printing reports with desired information.
- b) Interpret this information and translate it into the type and format desired for the target database. In most cases, this is done by manual interpretation.
- c) Transfer the data from the source(s) to the reliability data bank using any suitable method. Suitable “off-the-shelf” software can be used to transfer data from one database to another with the desired “language” conversion done by software algorithms. This is only feasible as long as a conversion algorithm, sufficiently robust to make a confident conversion, can be defined. These methods do require some extra effort upfront and, therefore, are only cost-effective for large quantities of data or repetitive data collection of the same category. It may also be used for maintenance when transferring data from one CMMIS to another.
- d) Data collection methods significantly impact the cost-benefit analysis for data collection and shall, therefore, be carefully planned and tested before the main data collection process is started.

7.2.3 Organization and training

Data collection may be done either within the company using internal resources or as a task done by more specialized companies or personnel. As data are, by nature, “historical”, it evidently takes some time before sufficient data are accumulated to draw valid conclusions based on statistics only. The cost-benefit analysis for collecting data can take some time to become evident but annual tracking of equipment performance captures a useful history.

Data collection can require skills from several categories, viz. IT, reliability/statistics, maintenance, operation and data collection. Key personnel shall be familiar, in particular, with the data collection concept and any specific software for the data collection activity, and, to a reasonable extent, know the technical, operational and maintenance aspects of the equipment for which data are collected. Proper training of key personnel on these issues is necessary in order to obtain quality data. The personnel who check the quality of the data shall be different from those performing the data collection. Data collectors shall, as a pre-requisite, know this International Standard and should give feedback as appropriate.

Before data collection starts, it is useful to do a pilot exercise to check the available population, the quality of source information and the feasibility of the data collection methods. This serves as a model for what can be achieved within a given time and budget.

A system for dealing with deviations encountered in the data collection process, such as ambiguous definitions, lack of interpretation rules, inadequate codes, etc., shall be established and problems solved as soon as possible. It can be a major task to correct corrupt data after many data have been collected.

A data collection exercise shall also provide feedback by summarizing and evaluating all quality lessons learned during the planning and execution of the data collection effort. Recommendations shall then be fed back to the relevant personnel for improvement on definitions, maintenance systems (e.g. CMMIS-systems) and the data collection process and personnel.

8 Equipment boundary, taxonomy and time definitions

8.1 Boundary description

A clear boundary description is imperative for collecting, merging and analysing RM data from different industries, plants or sources. It also facilitates communication between operators and equipment manufacturers. Otherwise, the merging and analysis is based on incompatible data.

For each equipment class, a boundary shall be defined indicating what RM data are to be collected. This may be given by using a figure, a text definition or a combination of both.

An example of a boundary diagram is shown in [Figure 2](#) and an example of a definition to accompany the diagram is as follows:

EXAMPLE The boundary applies to both general-service and fire-fighting pumps. Inlet and outlet valves and suction strainer are not within the boundary. Furthermore, the pump drivers along with their auxiliary systems are not included. Driver units are recorded as separate inventories (electric motor, gas turbine or combustion engine) and it is important that the failures on the driver, if recorded, be recorded as part of the driver units. A number in the pump inventory gives a reference to the appropriate driver inventory.

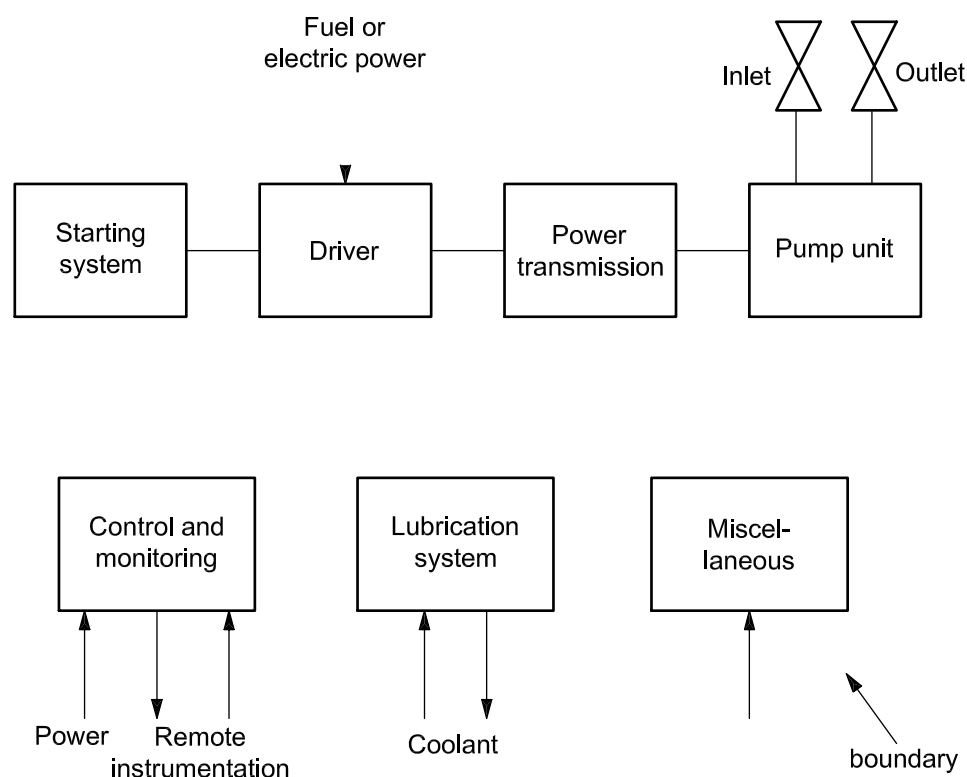

Figure 2 — Example of boundary diagram (pump)

Due attention shall be paid to the location of the instrument elements. In the above example, the central control and monitoring items are typically included within the “control and monitoring” subunit, while individual instrumentation (trip, alarm, control) is typically included within the appropriate subunit, e.g. lubrication system.

The boundary diagram shall show the main lower-level items and the interfaces to the surroundings. Additional textual description shall, when needed for clarity, state in more detail what shall be considered inside and outside the relevant boundary (see the Example associated with [Figure 2](#) where e.g. the driver of the pump is outside the boundary). When referring to this International Standard, it is vital that any deviation from the boundaries given in this International Standard, or new boundaries not given by this International Standard, be specified.

Boundaries shall avoid overlapping among different equipment classes. For example, when collecting data on instruments as separate equipment units, one shall avoid including those instruments that are also included within the boundaries of other equipment units on which data are being collected. Some overlapping can be difficult to avoid; however, such case(s) shall be identified and treated appropriately during the data analyses.

Recommended boundary diagrams for some selected equipment units are given in [Annex A](#).

8.2 Taxonomy

The taxonomy is a systematic classification of items into generic groups based on factors possibly common to several of the items (location, use, equipment subdivision, etc.). A classification of relevant data to be collected in accordance with this International Standard is represented by a hierarchy as shown in [Figure 3](#). Definitions of each segment are provided below, in addition to examples of different business streams and equipment types, as illustrated in [Table 2](#).

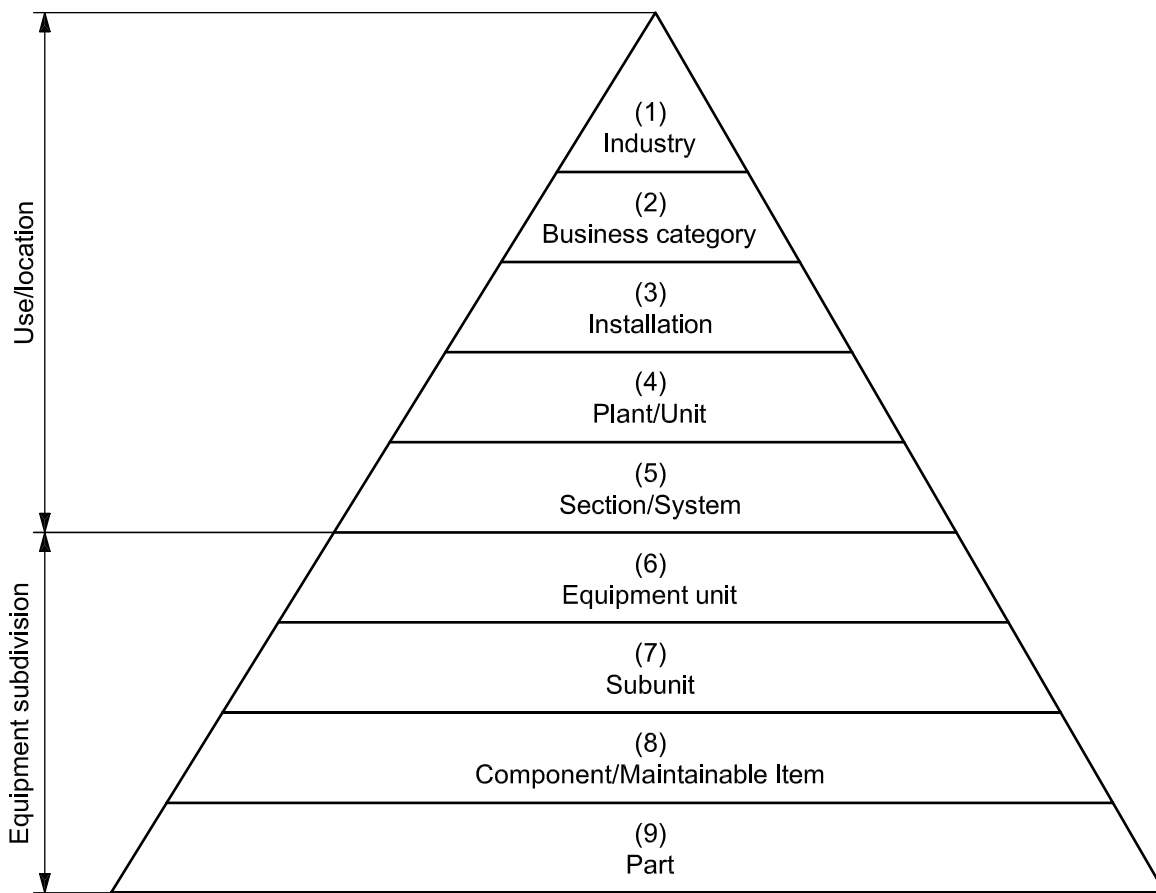

Figure 3 — Taxonomy classification with taxonomic levels

Table 2 — Taxonomy examples

Main category	Taxonomic level	Taxonomy hierarchy	Definition	Examples
Use/location data	1	Industry	Type of main industry	Petroleum, natural gas, petrochemical
	2	Business category	Type of business or processing stream	Upstream (E and P), midstream, downstream (refining), petrochemical
	3	Installation category	Type of facility	Oil/gas production, transportation, drilling, LNG, refinery, petrochemical (see Table A.1)
	4	Plant/Unit category	Type of plant/unit	Platform, semi-submersible, hydrocracker, ethylene cracker, polyethylene, acetic acid plant, methanol plant (see Table A.2)
	5	Section/System	Main section/system of the plant	Compression, natural gas, liquefaction, vacuum gas oil, methanol regeneration, oxidation section, reaction system, distillation section, tanker loading system (see Table A.3)
Equipment subdivision	6	Equipment class/unit	Class of similar equipment units. Each equipment class contains comparable equipment units (e.g. compressors).	Heat exchangers, compressors, piping, pumps, gas turbines, subsea wellhead and X-mas trees, lifeboats, extruders, subsea BOPs (see Table A.4)
	7	Subunit	A subsystem necessary for the equipment unit to function	Lubrication subunit, cooling subunit, control and monitoring, heating subunit, pelletizing subunit, quenching subunit, refrigeration subunit, reflux subunit, distributed control subunit
	8	Component/Maintainable item (MI) ^a	The group of parts of the equipment unit that are commonly maintained (repaired/restored) as a whole	Cooler, coupling, gearbox, lubrication oil pump, instrument loop, motor, valve, filter, pressure sensor, temperature sensor, electric circuit
	9	Part ^b	A single piece of equipment	Seal, tube, shell, impeller, gasket, filter plate, bolt, nut, etc.
^a For some types of equipment, there might not be a MI; e.g. if the equipment class is piping, there might be no MI, but the part could be “elbow”.				
^b While this level can be useful in some cases, it is considered optional in this International Standard.				

Levels 1 to 5 represent a high-level categorization that relates to industries and plant application regardless of the equipment units (see level 6) involved. This is because an equipment unit (e.g. pump) can be used in many different industries and plant configurations and, for analysing the reliability of similar equipment, it is necessary to have the operating context. Taxonomic information on these levels (1 to 5) shall be included in the database for each equipment unit as “use/location data” (see [Table 2](#)).

Levels 6 to 9 are related to the equipment unit (inventory) with the subdivision in lower indenture levels corresponding to a parent-child relationship. This International Standard focuses on the equipment unit level (level 6) for the collection of RM data and also indirectly on the lower indenture items, such as subunits and components. The number of subdivision levels for the collection of RM data depends on the complexity of the equipment unit and the use of the data. A single instrument might need no further breakdown, while several levels can be required for a large compressor. For data used in availability analyses, the reliability at the equipment-unit level can be the only data required, while an RCM analysis and root-cause analysis can require data on failure mechanism at the component/maintainable item, or parts, level. This International Standard does not specifically address level 9.

It is necessary that RM data be related to a certain level within the taxonomic hierarchy in order to be meaningful and comparable. For example, a failure mode shall be related to the equipment unit, while a failure mechanism shall be related to the lowest achievable level in the item hierarchy. [Table 3](#) gives guidance on this.

Table 3 — Reliability and maintenance parameters in relation to taxonomy levels

Recorded RM data	Hierarchy level ^a				
	4 Plant/Unit	5 Section/ System	6 Equipment unit	7 Subunit	8 Component/ Maintainable item
Impact of failure on safety	X ^b				
Impact of maintenance on safety	X				
Impact of failure on operations	X	(X) ^c			
Impact of maintenance with regard to operations	X	(X)			
Failure impact on equipment			X	(X)	(X)
Failure mode		(X)	X	(X)	(X)
Failure mechanism			(X)	(X)	X
Failure cause				(X)	X
Detection method		(X)	X	(X)	(X)
Subunit failed				X	
Component/maintainable item failed					X
Down time	(X)	(X)	X		
Active maintenance time			X	(X)	(X)
^a	See Figure 3 .				
^b	X = default.				
^c	(X) = possible alternatives.				

Regarding items on different hierarchy levels, many items may be found on different levels in the taxonomic hierarchy, depending on the context or the size of the item. For instance, valve and pump are equipment classes, but may also be maintainable items in a gas turbine. The valve is typically a maintainable item subsea and an equipment unit topside. Due care should be taken to avoid double-counting failure events when RM data are collected on such equipment.

For some systems it may be relevant to apply RM data collection also on Level 5 (system level, see [Table A.3](#)). Although many of the same principles as used for equipment data collection on Level 6-8 may apply, these should be used carefully as there could be large differences between the individual systems selected for the data collection.

8.3 Timeline issues

8.3.1 Surveillance and operating period

The equipment surveillance period is typically used as the time period for determining time-related reliability parameters, e.g. MTTF, component life, etc. For many equipment units, the operating, or in-service, period is less than the surveillance period due to maintenance, sparing of equipment or intermittent operation of the equipment (e.g. tank-transfer pumps).

When equipment is in an idle state or in “hot” standby, i.e. being ready for immediate operation when started, it is considered to be operating (or “in-service”) by the definitions in this International Standard. Equipment on standby, which would require some activities to be performed before being ready for operation (“cold” standby) is not considered to be in an operating state. The various time-period definitions are illustrated in [Table 4](#).

Data may also be collected for actual preventive maintenance if one wants the full picture of down time caused by all maintenance actions (see [Table 4](#)). Periods when equipment is deliberately taken

out of service for an extended period, or is being modified, are not considered to be relevant for data collection.

The surveillance period may also cover several states in the life of the item. For example, in the subsea environment, equipment can be installed and functioning, i.e. a barrier to the escape of downhole hydrocarbons, but the well might not start producing for several months. Failures can occur on the equipment during this phase, requiring it to be repaired with a potential delay to start-up. Likewise, equipment can fail during a refinery turnaround, which is not a “production” phase, again requiring repair and possible delay to start-up.

Table 4 — Timeline definitions

Total time ^h													
Down time								Up time					
Planned down time				Unplanned down time				Operating time				Non-operating time	
Preventive maintenance		Other planned outages		Corrective maintenance		Other unplanned outages							
Preparation and/or delay	Active preventive maintenance (item being worked on) ^f	Reserve ^a	“Modification” ^b	Undetected faults ^g	Preparation and/or delay	Repair (item being worked on) ^c	Shut-down, operational problems/restrictions etc. ^d	Run-down	Start-up	Running ^e	Hot stand-by	Idle	Cold stand-by

^a Means that item is available for operation, but not required for some time. Does not include items considered as “spare parts” or items taken out of service on a more permanent basis.

^b Modification can change the reliability characteristics of an item and can, therefore, require that the collection of reliability data for the surveillance period be terminated before the modification and be re-started with a new surveillance period after the modification.

^c Includes fault diagnosis, repair action and testing (as required).

^d Shutdown of machinery (trip and manual shutdown), see definition of trip (3.93) and also C.1.8.

^e Running is the active operational period for equipment in oil & gas production systems. For drilling and workover systems, this is not sufficient since there are many different operational phases. The operational phases for drilling could include: Running, drilling, tripping, set casing; and, the phases for workover could include: well equipment removal, replace completion string, replace casing string, and various workover activities.

^f Includes testing

^g It is difficult to determine downtime associated with undetected faults. These faults are eventually revealed by test or demand.

^h See also ISO/TR 12489:2013, Figures 5, 6, and 7.

8.3.2 Data collection periods

Depending on use and feasibility, data may be recorded for the whole equipment lifetime or for shorter intervals. The latter is common due to both cost and obtaining the data within a reasonable time frame. As shown in Annex C, the lifetime of many items is assumed to follow the so-called “bathtub” curve. If only the RM data for the steady-state operating part of an item are required, data collection shall start after the burn-in period is considered to have ended. The length of this period can vary among equipment categories from no burn-in to several months. Data recorded during the steady-state operating period often follows, or is assumed to follow, the exponential lifetime curve (constant failure rate). For some equipment, it is also useful and essential to collect data from “day one” in order to accumulate experience on burn-in failures. In this case, data collected from what may be considered as an initial burn-in period shall be distinguished from data collected from the subsequent steady-state operating period.

The length of the data collection period shall be balanced against the expected failure rate, size of population and access to data. For equipment of high importance (safety) and equipment where one knows that few failures normally occur (subsea), a longer surveillance period is desirable (e.g. the whole lifetime history). It is even useful to collect data for equipment with no failures during the surveillance period because, by observing no failures in a given period, it is possible to estimate the failure rate by “censoring” the data. Methods within statistics shall be used to estimate the confidence of the data (upper/lower confidence limits), as shown in Annex C.

While the surveillance period is just an interval in the calendar time between two specific times and can, therefore, be defined exactly, operating time is not always that straightforward to determine. For some rotating equipment, the operating time is recorded on a counter and can be read exactly. For other equipment, this might not be true. Hence, it is often necessary to estimate operating time based on knowledge from the operating and/or maintenance staff. As the “true” failure rate for an item shall be calculated based on actual operation, high priority should be given to collecting or estimating this parameter.

8.3.3 Maintenance times

Two main calendar times during maintenance are recommended to be collected, viz. down time and active repair time. The difference between the two is illustrated in Figure 4. For further information on breakdown of the downtimes, see also ISO/TR 12489:2013, Figures 5 to 7, and ISO 20815:2008, Figure I.5.

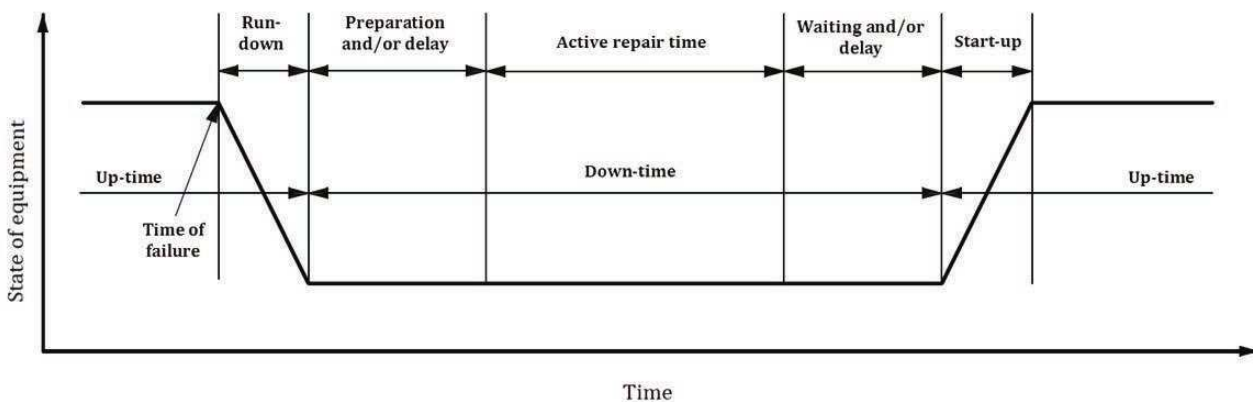

Figure 4 — Maintenance times

Down time includes the calendar time from the time the equipment is stopped for a repair until it is reconnected to its intended service after having been tested.

Active maintenance time” is the “active corrective maintenance time” then see ISO/TR 12489:2013, Figure 5, where “active corrective maintenance time” consists of the “active repair time” (MRT) and the “technical delay. Active maintenance time is the calendar time during which maintenance work on the item is actually performed. Hence, active repair time cannot normally be greater than the down time. However, exceptionally, active repair time can be greater than down time if the maintenance can be performed with the equipment unit operating. Note that the operational time required to run down the equipment before repair and start-up up after the repair is not considered to be part of the down time. Mobilization time is part of the preparation and/ or delay.

NOTE See relevant definitions regarding maintenance times in Clause 3.

9 Recommended data for equipment, failures and maintenance

9.1 Data categories

The RM data shall be collected in an organized and structured way. The major data categories for equipment, failure and maintenance data are the following.

a) Equipment unit data (inventory data)

The description of an equipment unit (level 6 in [Figure 3](#)) is characterized by the following:

- 1) classification data, e.g. industry, plant, location, system;
- 2) equipment attributes, e.g. manufacturer's data, design characteristics;
- 3) operational data, e.g. operating mode, operating power, environment.

These data categories shall be general for all equipment classes. Additionally, some data specific for each equipment class (e.g. number of stages for a compressor) are required. Recommended data for some equipment classes are given in [Annex A](#).

b) Failure data

These data are characterized by the following:

- 1) identification data, e.g. failure record number and related equipment that has failed;
- 2) failure data for characterizing a failure, e.g. failure date, items failed, failure impact, failure mode, failure cause, failure detection method.

c) Maintenance data

These data are characterized by the following:

- 1) identification data, e.g. maintenance record number, related failure and/or equipment record;
- 2) maintenance data, parameters characterising a maintenance action, e.g. date of maintenance, maintenance category, maintenance activity, impact of maintenance, items maintained;
- 3) maintenance resources, maintenance man-hours per discipline and total, utility equipment/resources applied;
- 4) maintenance times, active maintenance time, down time.

The type of failure and maintenance data shall normally be common for all equipment classes, with exceptions where it is necessary to collect specific types of data, e.g. subsea equipment.

Corrective-maintenance events shall be recorded in order to describe the corrective action following a failure. Preventive-maintenance records are required to retain the complete lifetime history of an equipment unit.

9.2 Data format

Each record, e.g. a failure event, shall be identified in the database by a number of attributes. Each attribute describes one piece of information, e.g. failure mode. It is recommended that each piece of information be coded where possible. The advantages of this approach versus free text are

- facilitation of queries and analysis of data,
- ease of data input,
- consistency check undertaken at input, by having predefined code lists,

— minimization of database size and response time of queries.

The range of predefined codes shall be optimized. A short range of codes is too general to be useful. A long range of codes gives a more precise description, but slows the input process and might not be used fully by the data collector. Selected codes shall, if possible, be mutually exclusive.

The disadvantage of a predefined list of codes versus free text is that some detailed information can be lost. For all categories mentioned in 9.1 a), b) and c), it is recommended to include some additional free text giving more explanatory information as available and deemed relevant, e.g. to include a narrative of the occurrence leading to a failure event. This would assist in quality checking the information and browsing through single records to extract more detailed information.

Examples of codes are given in [Annexes A](#) and [B](#) for different equipment types and reliability data. Generic reliability data will use such equipment data, and failure and maintenance characteristics. Regarding the generic reliability data, see also [D.5](#) and [Table D.5](#).

9.3 Database structure

9.3.1 Description

The data collected shall be organized and linked in a database to provide easy access for updates, queries and analysis. Several commercial databases are available that can be used as the main building blocks for designing a reliability database. Two aspects of organizing the structure of data shall be addressed as described in 9.3.2 and 9.3.3.

9.3.2 Logical structure

The logical structure defines the logical links among the main data categories in the database. This model represents an application-oriented view of the database. The example in [Figure 5](#) shows a hierarchical structure with failure and maintenance records linked to the equipment unit (inventory). Records describing preventive maintenance (PM) are linked to the inventory description in a many-to-one relation. The same applies for failures, which additionally have related corrective-maintenance records linked to each failure record. Each record (e.g. failure) may consist of several attributes (e.g. failure date, failure mode, etc.).

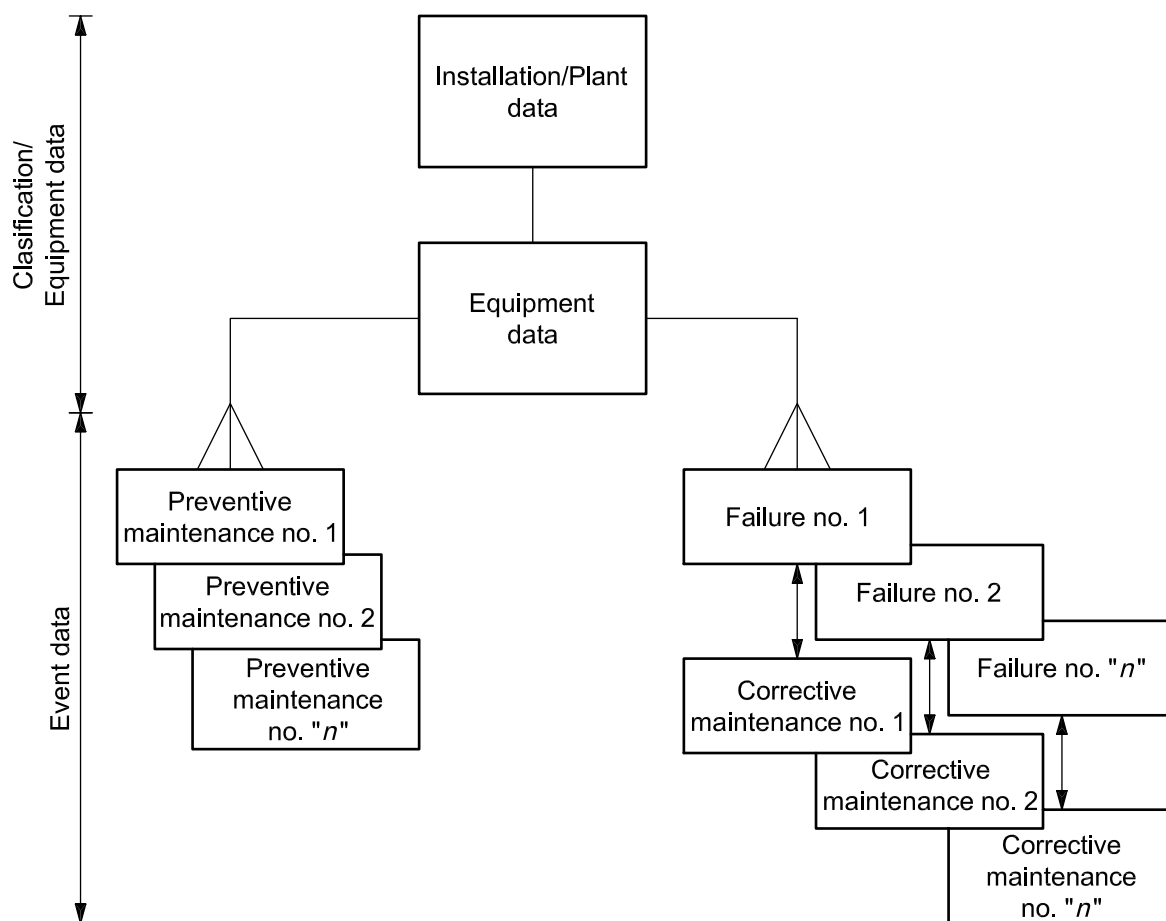

Figure 5 — Logical data structure (example)

9.3.3 Database architecture

This defines the design of the database as to how the individual data elements are linked and addressed. The following four model categories are commonly available, ranked from lowest to highest complexity and versatility:

- Hierarchical model:** Data fields within records are related by a “family tree” relationship. Each level represents a particular attribute of data.
- Network model:** This is similar to the hierarchical model; however, each attribute can have more than one parent.
- Relational model:** The model is constructed from tables of data elements, which are called relations. No access path is defined beforehand; all types of manipulation of the data in tabular form are possible. The majority of database designs use this concept.
- Object model:** The software is considered as a collection of objects, each of which has (1) a structure and (2) an interface. The structure is fixed within each object while the interface is the visible part that provides the link address between the objects. Object modelling enables the database design to be very flexible, extendable, reusable and easy to maintain. This model seems to be popular in new database concepts.

9.4 Equipment data

The classification of equipment into technical, operational and environmental parameters is the basis for the collection of RM data. This information is also necessary to determine whether the data are suitable or valid for various applications. Some data are common to all equipment classes and other data are specific to a particular equipment class.

To ensure that the objectives of this International Standard are met, a minimum of data shall be collected. These data are identified by an asterisk (*) in [Tables 5, 6](#) and [8](#). However, the addition of certain other data categories can significantly improve the potential usability of the RM data (see Annex D). In all cases, the minimum data collected on equipment level should allow a data exchange between the equipment owner (user) and the manufacturer. The minimum data shall encompass all data required to identify the equipment physical location at any given point in time, the main design attribute identifier used by both parties (e.g. manufacturer’s part number), manufacturer and unique identifier of each specific equipment item (typically manufacturer’s serial number).

Equipment data consists of two parts:

- equipment data common to all equipment classes;
- equipment specific.

[Table 5](#) contains the data common to all equipment classes. In addition, some data that are specific for each equipment class shall be recorded. [Annex A](#) gives examples of such data for some equipment classes. In the examples in [Annex A](#), the priority data are suggested, but they can vary according to each case or application. For some equipment specific data, low priority data can be difficult to obtain, but if available can be valuable for analysis of the specific equipment.

Table 5 — Equipment data common to all equipment classes

Data category	Data	Taxonomic level ^a	Business category (examples)			
			Upstream (E & P)	Midstream	Downstream (refining)	Petrochemical
Use/ Location attributes	Industry	1	Petroleum	Natural gas	Petroleum	Petrochemical
	Business category (*)	2	E & P	Midstream	Refining	Petrochemical
	Installation category	3	Oil/gas production	Pipeline	Refinery	Petrochemical
	Installation code or name (*)	3	Delta	Beta gas line	Charlie refinery	Delta chemical
	Owner code or name	4	Smith Ltd.	Johnsen Inc.	JPL Corp.	ABC ASA
	Geographic location	3	UKCS	Europe	Mid-west USA	UK
	Plant/Unit category (*)	4	Oil/gas platform	Compressor station	Hydro-cracker	Ethylene cracker
	Plant/Unit code or name (*)	4	Alpha 1	CS 3	HH 2	EC 1
	Section/System (see Annex A) (*)	5	Oil processing	Compression	Reaction	Reaction system
	Operation category	5	Remote control	Remote control	Manned	Manned

Table 5 (continued)

Data category	Data	Taxonomic level ^a	Business category (examples)			
			Upstream (E & P)	Midstream	Downstream (refining)	Petrochemical
Equipment attributes	Equipment class (see Annex A) (*)	6	Pump	Compressor	Heat exchanger	Heater
	Equipment Type (see Annex A) (*)	6	Centrifugal	Centrifugal	Shell and tube	Fired
	Equipment identification/Location (e.g. tag number) (*) ^b	6	P101-A	C1001	C-21	H-1
	Equipment description (nomenclature)	6	Transfer	Main compressor	Reactor effluent	Charge heater
	Unique equipment identification number ^b	6	12345XL	10101	Cxy123	909090
	Manufacturer's name (*) ^c	6	Johnson	Wiley	Smith	Anderson
	Manufacturer's model designation ^g	6	Mark I	CO ₂	GTI	SuperHeat A
	Design data relevant for each equipment class and subunit/component as applicable, e.g. capacity, power, speed, pressure, redundancy, relevant standard(s) (see also Annex A)	6 - 8	Equipment-specific	Equipment-specific	Equipment-specific	Equipment-specific
Operation (normal use)	Normal operating state/Mode (*)	6	Running	Active stand-by	Intermittent	Running
	Initial equipment commissioning date	6	2003.01.01	2003.01.01	2003.01.01	2003.01.01
	Start date of current service (*)	6	2003.02.01	2003.02.01	2003.02.01	2003.02.01
	Surveillance time, h (calculated) (*)	6	8 950	8 000	5 400	26 300
	Operational time, h ^d (measured/calculated)	6	7 540	675	2 375	22 870
	Number of periodic test demands during the surveillance period as applicable (*) ^e	6 - 8	4	2	2	4
	Number of operational demands during the surveillance period as applicable (*) ^e	6 - 8	4	5	11	3
	Total wells drilled during surveillance period (*) ^f	4	42	N.A.	N.A.	N.A.
	Operating parameters as relevant for each equipment class; e.g. ambient conditions, operating power (see Annex A)	6	Equipment-specific	Equipment-specific	Equipment-specific	Equipment-specific

Table 5 (continued)

Data category	Data	Taxonomic level ^a	Business category (examples)			
			Upstream (E & P)	Midstream	Downstream (refining)	Petro-chemical
Additional information	Additional information in free text as applicable	6	Specify as needed	Specify as needed	Specify as needed	Specify as needed
	Source of data, e.g. P & ID, data sheet, maintenance system	6	Specify as needed	Specify as needed	Specify as needed	Specify as needed
<p>^a See definitions in Figure 3.</p> <p>^b A specific individual equipment unit has an “Unique equipment identification number” (serial number), and this may be required for documenting potential change-out at the equipment level. The tag number identifies the equipment function and its physical location. If the equipment is replaced with, e.g. an overhauled unit, the tag number (and part number) remains the same, but the serial number changes. Operator and equipment supplier may have different “Unique equipment identification number” for same specific equipment unit. See also ISO 15926-2:2003, E.3.3 which describes this relationship in more detail.</p> <p>^c Manufacturer may be relevant for lower hierarchical levels, i.e. level 7 and 8.</p> <p>^d Equipment may be subject to different operational phases, such as for example for equipment used in drilling operations</p> <p>^e See further information on number of demands in C.1.3.</p> <p>^f This applies only to drilling related equipment classes.</p> <p>^g Equipment classes, subunits or maintainable items within some equipment classes can have the need to have a separate information field in the equipment specific data (Level 6-8 in the taxonomy in Figure 3) to reflect the technology generation, to distinguish between older and new technology in reliability data collection and analysis.</p> <p>(*) indicates the minimum data that shall be collected.</p>						

9.5 Failure data

A uniform definition of failure and a method of classifying failures are essential when it is necessary to combine data from different sources (plants and operators) in a common RM database.

A common report, as given in [Table 6](#) (see also [Table 3](#)), for all equipment classes shall be used for reporting failure data. For some equipment classes, e.g. subsea equipment, minor adaptations can be necessary.

Table 6 — Failure data

Data category	Data to be recorded	Description
Identification	Failure record (*)	Unique failure record identification
	Equipment identification/Location (*)	E.g. tag number (see Table 5)
Failure data	Failure date (*)	Date of failure detection (year/month/day)
	Failure mode (*)	Usually at equipment-unit level (level 6) (see B.2.6) ^a
	Failure impact on plant safety (e.g. personnel, environment, assets) ^b	Qualitative or quantitative failure consequence categorization (see also C.1.10)
	Failure impact on plant operations (e.g. production, drilling, intervention) ^b	Qualitative or quantitative failure consequence categorization (see also C.1.10)
	Failure impact on equipment function (*)	Effect on equipment-unit function (level 6): critical, degraded, or incipient failure ^c
	Failure mechanism	The physical, chemical or other processes which have led to a failure (see Table B.2)
	Failure cause ^d	The circumstances during design, manufacture or use which have led to a failure (see Table B.3)
	Subunit failed	Name of subunit that failed (see examples in Annex A)
	Component/Maintainable item(s) failed	Name of the failed component/maintainable item(s) (see Annex A)
	Detection method	How the failure was detected (see Table B.4)
	Operating condition at failure (*)	Run-down, start-up, running, hot standby, idle, cold standby, testing
Operational phase at failure ^e	Type of operation at the time of failure	
SIS failure mode classification ^f	Classify the failure for the specific event (DU, DD, SU, SD; see F.2) ^g	
Remarks	Additional information	Give more details, if available, on the circumstances leading to the failure: failure of redundant units, failure cause(s) etc.
<p>^a For some equipment categories such as subsea equipment, it is recommended to also record failure modes on taxonomic levels lower than the equipment-unit level.</p> <p>^b See example of failure consequence classification in Table C.2</p> <p>^c For some equipment categories and applications it may be sufficient to record critical and non-critical (degraded + incipient) failures only.</p> <p>^d The failure cause and sometimes the failure mechanism are not known when the data are collected, as they commonly require a root cause analysis to be performed. Such analysis shall be performed for failures of high consequence, high repair/down time cost, or failures occurring significantly more frequent than what is considered “normal” for this equipment unit class (“worst actors”).</p> <p>^e Relevant for some equipment, e.g. drilling, completion and workover equipment. The code table depends on equipment category. The operation at the time of failure should be specified, such as drilling, tripping, cementing, perforating, well killing, etc.</p> <p>^f This is for data collection purposes internally for the company and for applications on the specific installation where it is collected. Carefulness if generalizing due to possible differences in classification for the same equipment class on same or different installations.</p> <p>^g The classes, DU (dangerous undetected), DD (dangerous detected), SU (safe undetected), SD (safe detected), are defined in IEC 61508-4:2010. See also ISO/TR 12489:2013.</p> <p>(*) indicates the minimum data that shall be collected.</p>		

The minimum data needed to meet the objectives of this International Standard are identified by (*) in [Table 6](#). However, the addition of certain other data categories can significantly improve the potential usability of the RM data; see [Annex D](#).

9.6 Maintenance data

9.6.1 General

Maintenance is carried out for the following reasons:

- to correct a failure (corrective maintenance); the failure shall be reported as described in 9.5;
- as a planned and normally periodic action to prevent failure from occurring (preventive maintenance).

A common report for all equipment classes shall be used for reporting maintenance data. The data required are given in [Table 8](#). For some equipment classes, minor adaptations can be required (e.g. subsea equipment).

The minimum data needed to meet the objectives of this International Standard are identified by (*) in [Table 8](#). However, the addition of other data categories can significantly improve the potential usability of the RM data; see Annex D.

9.6.2 Maintenance categories

There are two basic categories of maintenance:

- a) that done to correct an item after it has failed (corrective maintenance);
- b) that done to prevent an item from failing (preventive maintenance); part of this can be simply the checks (inspections, tests) to verify the condition and performance of the equipment to decide whether or not any preventive maintenance is required.

NOTE “Modification” is not defined as a maintenance category but is a task often performed by the maintenance organization. A modification can have an influence on the reliability and performance of an item.

[Figure 6](#) shows the main maintenance categories in more detail. [Table B.5](#) presents the main types of maintenance activities commonly performed.

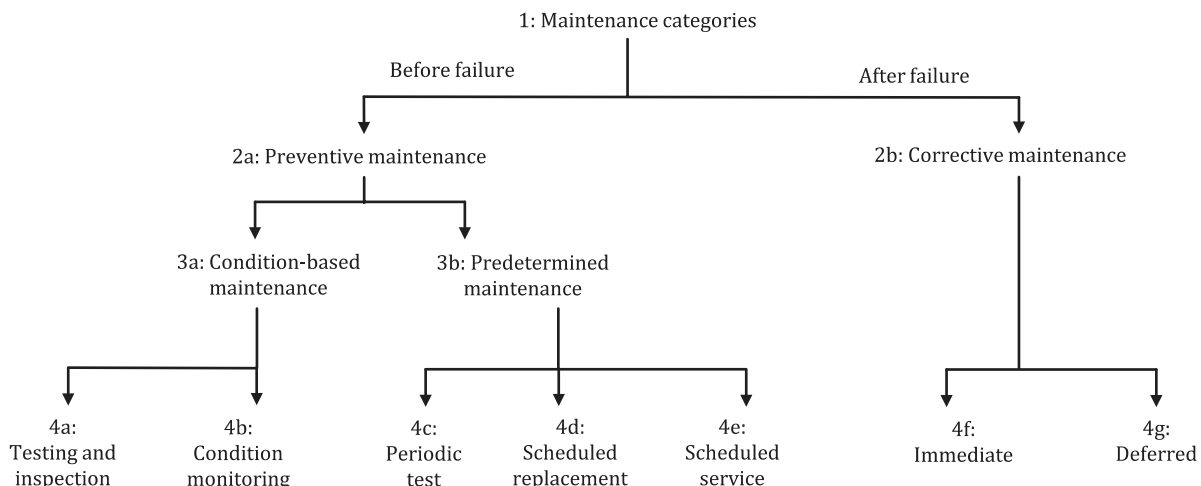

NOTE 3b — Predetermined maintenance, see EN 13306:2010, 7.2; 4c — Periodic test (as defined in 3.74) to detect potential hidden failures; 4e — In this International Standard, the term “scheduled service” is used, since it is meant to cover minor and major life-prolonging service activities; 4g — Deferred maintenance should also include planned corrective maintenance, i.e. where run-to-failure is the chosen failure management strategy.

Figure 6 — Maintenance categorization

9.6.3 Reporting maintenance data

9.6.3.1 Corrective maintenance

As a minimum for recording the reliability of an item, it is required that the corrective maintenance to correct a failure shall be recorded.

Analysing failure data requires attention if there are many repetitive failures on same equipment or critical failures on production critical equipment. This can include performing a root cause analysis, based on the underlying failure characteristics (failure mode, failure cause and failure mechanism). Improvements may be required to prevent recurrence, extend service life or improve ability to detect the failures earlier.

9.6.3.2 Preventive maintenance

It is recommended that the recording of the actual preventive maintenance (PM) be done essentially in the same way as for corrective actions. This can give the following additional information:

- full lifetime story of an item (all failures and maintenance);
- total resources used on maintenance (man-hours, spare parts);
- total down time and, hence, total equipment availability, both technical and operational; see Annex C;
- balance between preventive and corrective maintenance.

Recording PM actions is useful mainly for the maintenance engineer, but is also useful for the reliability engineer wanting to record or estimate the availability of equipment. A lifetime analysis takes into account not only failures but also maintenance actions intended to restore the item to “as-good-as-new” condition. PMs are often performed on a higher indenture level (e.g. “package” level); hence there might not be any data available that can be related to the items on the lower indenture level (subunit, maintainable item). It is necessary to consider this restriction when defining, reporting and analysing PM data.

During the execution of PM actions, impending failures can be discovered and corrected as part of the PM activities. In this case, the failure(s) shall be recorded as any other failure with the subsequent corrective action done, even though it initially was considered to be a PM-type activity. The failure-detection method shall, in this case, be considered as the type of PM being done. It is, however, realized that some failures, generally of minor character, can be corrected as part of the PM and not recorded individually. The practice on this can vary among companies and should be addressed by the data collector(s) in order to reveal the possible type and amount of failures being included within the PM program.

9.6.3.3 Preventive maintenance programme

A final option is to record the planned PM programme as well. In this case, it is possible to additionally record the differences between the planned PM and the PM actually performed (backlog). An increasing backlog indicates that control of the conditions of the plant is being jeopardized and can, in adverse circumstances, lead to equipment damage, pollution or personnel injury. Establishing the maintenance concept (for the purpose of PM programme during pre-operation) for various equipment categories and associated equipment classes should benefit from the use of this International Standard.

Condition-based maintenance (CBM) is important for some type of equipment category: e.g. rotating. Consideration of condition monitoring for predictive maintenance purposes should also utilise the failure and maintenance data reflected in this International Standard. The availability of the conditional monitoring system in itself and operational procedures are also important to gain benefit of CM.

[Table 7](#) shows a summary of data to be collected and possible added value for different data categories. Annex D contains a more detailed survey of data requirements for various applications.

Table 7 — Usefulness of maintenance data

Data to be collected	Priority with regard to data collection	Examples
Corrective maintenance	Required (see Table 8)	<ul style="list-style-type: none"> Repair time (MTTRes or MRT) Amount of corrective maintenance Replacement/repair strategy
Actual preventive maintenance	Optional	<ul style="list-style-type: none"> Full lifetime story of the equipment Total resources used on maintenance Total down time Effect of PM on failure rate Balance between corrective and preventive maintenance
Planned preventive maintenance (maintenance programme)	Optional	<ul style="list-style-type: none"> Difference between real and planned PM (backlog) Updating programme based on experiences (methods, resources, intervals)

Table 8 — Maintenance data

Data category	Data to be recorded	Description ^a
Identification	Maintenance record (*)	Unique maintenance identification
	Equipment identification/location (*)	e.g. tag number (see Table 5)
	Failure record (*)	Corresponding failure identification record (not relevant for preventive maintenance)
Maintenance data	Date of maintenance (*)	Date when maintenance action was undertaken or planned (start date)
	Maintenance category (*)	Main category (corrective, preventive)
	Maintenance priority	High, medium or low priority
	Interval (planned)	Calendar or operating interval (not relevant for corrective maintenance)
	Maintenance activity	Description of maintenance activity, see Annex B, Table B.5
	Maintenance impact on plant operations	Zero, partial or total
	Subunit maintained	Name of subunit maintained (see Annex A) ^b (may be omitted from preventive maintenance).
	Component/maintainable item(s) maintained	Specify the component/maintainable item(s) that were maintained (see Annex A) (may be omitted from preventive maintenance).
Spare part location	Availability of spares (e.g. local/distant, manufacturer)	
Maintenance resources	Maintenance man-hours, per discipline ^c	Maintenance man-hours per discipline (mechanical, electrical, instrument, others)
	Maintenance man-hours, total	Total maintenance man-hours
	Maintenance equipment resources ^c	e.g. intervention vessel, crane

Table 8 (continued)

Data category	Data to be recorded	Description ^a
Maintenance times	Active maintenance time ^d (*)	Time duration for active maintenance work being done on the equipment (see also definitions in Table 4)
	Down time ^d (*)	Time duration during which an item is in a down state (see also Table 4 and Figure 4)
	Maintenance delays/problems	Prolonged down time causes, e.g. logistics, weather, scaffolding, lack of spares, delay of repair crew
Remarks	Additional information	Give more details, if available, on the maintenance action and resources used
<p>^a Records to be entered for both corrective and preventive maintenance, except where shown.</p> <p>^b For corrective maintenance, the subunit maintained is normally identical to the one specified on the failure event report (see Table 6).</p> <p>^c For subsea equipment, the following apply:</p> <ul style="list-style-type: none"> — type of main resource(s) and number of days used, e.g. drilling rig, diving vessel, service vessel; — type of supplementary resource(s) and number of hours used, e.g. divers, ROV/ROT, platform personnel. <p>^d This information is desirable for RAM and RCM analyses. It is currently infrequently recorded in the maintenance-management systems. It is necessary to improve the reporting of this information to capture reasons for long down times.</p> <p>(*) indicates the minimum data that shall be collected.</p>		

Annex A (informative)

Equipment-class attributes

A.1 Advisory notes

A.1.1 General

[Annex A](#) provides examples on how typical equipment used in the petroleum, petrochemical and natural gas industries can be categorized as to their taxonomy, boundary definition, and inventory data. These data are informative for each equipment unit. Normative data, e.g. failure modes, for the equipment examples are shown in [Annex B](#).

A standardized approach has been applied for some of the subunits that are used on a majority of equipment classes (e.g. control and monitoring, lubrication system, cooling system). The result that is the total number of tables required to describe the different data categories and definitions is reduced and, at the same time, there are fewer tailor-made definitions and codes for each individual equipment unit. The user should, therefore, apply those categories and codes that are applicable to the equipment for which data are being collected. Equipment having a unique design can require a more tailor-made categorization instead of that shown in these examples.

In the tables that describe the “equipment-unit subdivision” for the equipment, it is recommended to also include the following:

- a) “Maintainable items/Parts” on an as-needed basis, e.g. to include instrumentation;
- b) “Others”, if defined “Maintainable items/Parts” are lacking; or
- c) “Unknown” category, if sufficient information is not available.

The priority classes given in this annex are high, medium and low. When interpreting or assessing the value of these classes, they can be equated to compulsory (high), highly desirable (medium) and desirable (low).

A.1.2 Boundary definitions

The purpose of the boundary definition is to ensure a common understanding of the “subunit/component” and “maintainable item/part” included within the boundary of a particular equipment unit and, hence, which failure and maintenance events to record. For definition of the boundaries, the following rules are recommended.

- a) Do not include items of unique design or configuration-dependent items. Include only those items that are considered to be generic for the equipment class being considered in order to compare “like with like.”
- b) Exclude connected items from the equipment-class boundary, unless specifically included by the boundary specification. Failures that occur in a connection (e.g. leak), and that cannot be solely related to the connected item, should be included within the boundary definition.
- c) If a driver and the driven unit use a common subunit (e.g. lubrication system), relate failure and maintenance events on this subunit, as a general rule, to the driven unit;
- d) Include instrumentation only where it has a specific control and/or monitoring function for the equipment unit in question and/or is locally mounted on the equipment unit. Control and

supervisory instrumentation of more general use (e.g. SCADA-systems) should not, as a rule, be included;

- e) Proper use of P&ID when defining items within the equipment class boundary.

In A.2.2 to A.2.10 examples of boundary diagrams for different equipment classes are presented. This list is not exhaustive for the equipment categories covered by this International Standard, but includes examples on how taxonomies may be defined for typical equipment found in the petroleum, petrochemical and natural gas industries.

A.1.3 Common equipment data

This International Standard recommends some common equipment data that should be collected for all equipment classes as shown in [Table 5](#).

Note that some data in [Table 5](#) is only valid for certain equipment categories. This applies for example for the information fields, “Number of periodic test demands during the surveillance period as applicable” and “Number of operational demands during the surveillance period as applicable”. The use of such data for reliability analysis is further addressed in C.1.3.

Additionally, some equipment-specific data for equipment classes are presented in this annex. These data have been found to be useful when comparing performance, or benchmarking, of equipment.

Such design features specific for each equipment class should be considered depending on how far down in equipment categorization the data collector wants, or is required, to go. Collection of data is a trade-off between the cost of obtaining it, which often can be high, and the value of the data in relation to the specific requirements to define each equipment class for the intended analyses. The accessibility of the data in the source(s) also sets a limit on the data that can be collected. An indication of the importance of each data type is indicated. This importance ranking can differ among different users and applications.

A.1.4 Equipment classification and application

[Tables A.1](#) to [A.4](#) provide a methodology for grouping different equipment examples and their application as covered by this International Standard. These lists are not meant to be exhaustive but are intended to show the main types of equipment classes and systems and how they can be grouped in categories. Any applied categorization should be appropriate for the intended use and purpose of the data being collected (see 7.1.2). [Tables A.1](#) to [A.4](#) show a categorization related to the taxonomic levels shown in [Figure 3](#).

- [Table A.1](#) shows a recommendation for grouping equipment on installation level (level 3 in the taxonomic hierarchy).
- [Table A.2](#) shows a recommendation for how equipment can be classified on plant/unit level (level 4), as shown in [Table 5](#).
- [Table A.3](#) shows a list of relevant sections/systems (level 5) within the petroleum, natural gas and petrochemical industries where equipment as covered by this International Standard can be used. The systems where the equipment is applied should be recorded as one parameter in the general equipment data shown in [Table 5](#) (category “Use/Location”).
- [Table A.4](#) lists typical examples of equipment units used in the petroleum, natural gas and petrochemical industry as covered by this International Standard (level 6). [Table A.4](#) also indicates those equipment taxonomies that are illustrated by examples, as described in A.2.1. B.2.6 contains the associated failure modes for the same equipment examples. Some equipment related references (e.g. ISO and IEC standards) are also listed for selected equipment classes.

In the classification shown in [Tables A.1](#) to [A.3](#), the terms “upstream,” “midstream,” “downstream” and “petrochemical” are used. For definitions of these terms, see Clause 3.

The equipment categories in [Table A.4](#) have various functions, and is mean to categorize the prioritized equipment classes covered in this standard, e.g. principal operations like rotating, mechanical, and electrical; whereas others are process application groups, e.g. drilling, subsea production, and utilities.

Note that ISO 19008:2016 has a classification system used for standard cost coding, where Physical Breakdown Structure (PBS) and Code of Resources (COR) also address systems listed in [Table A.3](#) and equipment listed in [Table A.4](#), respectively.

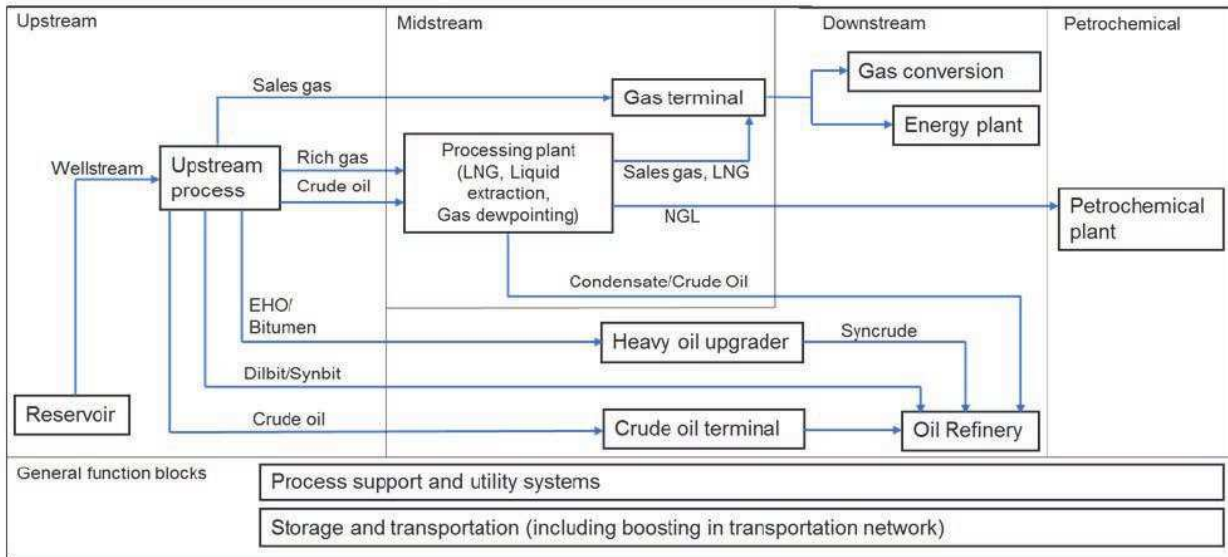

Figure A.1 — Process technology function blocks in the oil and gas value chain — Level 3

Table A.1 — Installation category — Level 3

Business category			
Upstream (E & P)	Midstream	Downstream	Petrochemical
Oil/gas production facility (offshore/ onshore)	Liquefied natural gas (LNG)	Refinery	Petrochemical complex
SAGD facility (onshore)	Liquefied petroleum gas (LPG)	Gas conversion	Terminal
Drilling facility (offshore/ onshore)	Gas processing	Energy plant	Pipeline
Maritime vessel	Terminal	Pipeline	
Terminal	Storage	Terminal	
Pipeline	Shipping	Biofuels	
Floating LNG (FLNG)	Pipeline		

Note 1: Shipping is defined as any means of transportation (sea, rail, road).
 Note 2: Gas conversion includes Gas to Liquids (GTL).
 Note 3: Combined heat and power (CHP) is part of Energy plant.
 Note 4: Drilling facility could be separate or integrated as part of other onshore/offshore installation.

Table A.2 — Plant/Unit level classification — Level 4

Business category			
Upstream (E & P)	Midstream	Downstream	Petrochemical
Drilling Mobile offshore drilling unit (MODU) Onshore drilling rig Offshore Offshore platform Floating production storage and offloading (FPSO) Floating drilling, production storage and offloading (FDPSO) Floating storage unit (FSU) Compliant tower Tension leg platform (TLP) Offshore loading Subsea production Maritime Subsea intervention and support vessel (SISV) Installation vessel Onshore Onshore production plant – conventional wells Onshore production plant – nonconventional wells	NGL extraction NGL fractionation Pipeline compressor station Pipeline pump station Utilities Offloading	Downstream-Process Gas To Liquid (GTL) Combined Heat & Power (CHP) Biofuel Refinery – Process Crude Distillation Unit Delayed Coking Unit Hydrotreating Unit Fluid Catalytic Cracking Unit Sulfur-recovery unit Hydrogen generation Tail Gas Recovery Unit General Utilities Offsite and support facilities	Methanol Ethylene Acetic Acid Polyethylene Polypropylene Polyvinylchloride Utilities Offsite and support facilities

Table A.3 — System/Section classification — Level 5

Business category			
Upstream (E & P)	Midstream	Downstream	Petrochemical
Process — General	Process — General	Crude Distillation	Process — General
S1. Oil process/ treatment	S28. Oil process/ treatment	S40. Preheating train	S57. Hydrogen steam reforming
S2. Gas process/ treatment	S29. Gas process/ treatment	S41. Desalting	S58. Isomerization
S3. Water injection	S30. Oil/condensate export	S42. Atmospheric	S59. Phenol extraction
S4. Oil/condensate export	S31. Gas export	S43. Vacuum	S60. Polymerization unit
S5. Gas export	Midstream utilities	Hydrotreating	S61. Solvent deasphalting
S6. Storage	S32. Fuel gas	S44. Feed	S62. Solvent dewaxing
Upstream utilities ^a	S33. Waste water treatment	S45. Reaction	S63. Solvent extraction
S7. Oily water treatment	LNG process	S46. Recycling	S64. Steam cracking
S8. Closed drains	S34. Gas treatment	S47. Stripping	S65. Steam-methane reforming
S9. Methanol	S35. Liquefaction	S48. Drying	S66. Sweetening
S10. Fuel gas	S36. Fractionation	Fluid Catalytic Cracking	
S11. Fresh water	S37. Refrigeration	S49. Feed	
Offshore systems	S38. LNG storage and loading	S50. Conversion	
S12. Ballast water	LNG utilities	S51. Gas compression	
S13. Seawater	S39. Refrigerant storage	S52. Gas recovery	
S14. Position keeping		S53. Debutanizer	
S15. Ice management		Downstream utilities	
Drilling and well		S54. Fuel gas	
S16. Drilling facilities		S55. SNOX	
S17. Drilling process		S56. Waste water treatment	
S18. Drilling well control			
S19. Drilling control and monitoring			
S20. Riser and well topside			
S21. Well production/injection ^c			
S22. Well completion			
S23. Well workover			
Subsea			
S24. Subsea, umbilical, riser and flowline (SURF) ^d			
S25. Subsea workover			
S26. Subsea processing			
S27. Subsea processing utilities			

Table A.3 (continued)

Business category			
Upstream (E & P)	Midstream	Downstream	Petrochemical
Safety and control systems (applicable for all business categories)			
S67.	Emergency depressurization (EDP) (Blowdown) (cf. ISO/TR 12489:2013, Table A.1, System 3)		
S68.	Emergency shutdown (ESD) (cf. ISO/TR 12489:2013, Table A.1, System 1)		
S69.	Process shutdown (PSD) (cf. ISO/TR 12489:2013, Table A.1, System 2)		
S70.	Fire and gas detection (cf. ISO/TR 12489:2013, Table A.1, System 6)		
S71.	Fire water (cf. ISO/TR 12489:2013, Table A.1, System 7)		
S72.	Fire-fighting (cf. ISO/TR 12489:2013, Table A.1, System 8)		
S73.	Flare (cf. ISO/TR 12489:2013, Table A.1, System 20)		
S74.	Process control (cf. ISO/TR 12489:2013, Table A.1, System 9)		
S75.	Emergency communication ^e (cf. ISO/TR 12489:2013, Table A.1, System 11)		
S76.	Evacuation system (cf. ISO/TR 12489:2013, Table A.1, System 12)		
S77.	Inert gas (includes cargo tank and blanket)		
S78.	Open drains		
Utilities (applicable for all business categories)			
S79.	Steam		
S80.	Main power ^b		
S81.	Emergency power ^b (cf. ISO/TR 12489:2013, Table A.1, System 18)		
S82.	Essential power ^b		
S83.	Instrument air		
S84.	Utility air		
S85.	Cooling		
S86.	Heating		
S87.	Nitrogen		
S88.	Chemical injection (cf. ISO/TR 12489:2013, Table A.1, System 10)		
S89.	Loading (cf. ISO/TR 12489:2013, Table A.1, System 15)		
S90.	Helicopter refuelling		
S91.	Electrical power protection		
S92.	Fiscal metering		
Auxiliaries ^f (applicable for all business categories)			
S93.	Telecommunications ^e (cf. ISO/TR 12489:2013, Table A.1, System 19)		
S94.	HVAC (cf. ISO/TR 12489:2013, Table A.1, System 21)		
S95.	Disconnection (cf. ISO/TR 12489:2013, Table A.1, System 13)		
S96.	Materials handling (cf. ISO/TR 12489:2013, Table A.1, System 22)		
S97.	Saturation diving (cf. ISO/TR 12489:2013, Table A.1, System 31)		
a	These sections/systems can also be applicable for downstream and petrochemical unless defined specifically for these categories.		
b	Includes both power generation and distribution.		
c	Well production/ injection includes the surface wellhead and X-mas tree.		
d	SURF includes SPS (subsea production system).		
e	Regarding telecommunications; this could be subdivided or extended with the following systems: Security, Communication, Navigation aids, Collision avoidance and Metocean data gathering.		
f	Regarding the difference between auxiliaries and utilities. Auxiliaries are providing supplementary or additional help and support. This is a difference from Utilities which are intended to provide service to multiple equipment whereas auxiliary equipment tends to focus on support to a single system, e.g. an auxiliary fuel tank for an engine.		

Table A.4 — Equipment class — Level 6

Equipment category	Equipment class — Level 6	Equipment class code	Example included in Annex A	References
Rotating (A.2.2)	Blowers and fans g	BL	No	API/Std 673 API/Std 560
	Centrifuges	CF	No	
	Combustion engines	CE	A.2.2.1	ISO 8528 API RP 7C-11F API Spec 7B-11C
	Compressors	CO	A.2.2.2	ISO 10439 (all parts) ISO 13631 ISO 13707 ISO 10442 API/Std 617 API/Std 618 API/Std 619
	Electric generators	EG	A.2.2.3	BS 4999-140 IEEE C37.101 IEEE C37.102 NEMA MG 1
	Electric motors	EM	A.2.2.4	IEC 60034-12 IEC 60470 IEC 60947-4-1 API/Std 541 API/Std 547 NEMA MG 1
	Gas turbines	GT	A.2.2.5	ISO 3977 (all parts) ISO 2314 API/Std 616
	Liquid expanders	LE	No	
	Mixers	MI	No	
	Pumps	PU	A.2.2.6	ISO 13709 ISO 13710 API/Std 610 API/Std 674 API/Std 676
	Steam turbines	ST	A.2.2.7	ISO 10437 API/Std 611 API/Std 612
	Turboexpanders	TE	A.2.2.8	API/Std 617
Mechanical (A.2.3)	Conveyors and elevators	CV	No	

Table A.4 (continued)

Equipment category	Equipment class — Level 6	Equipment class code	Example included in Annex A	References
	Cranes	CR	A.2.3.1	
	Filters and strainers	FS	No	
	Heat exchangers	HE	A.2.3.2	ISO 12211 ISO 12212 ISO 16812 ISO 13706 ISO 15547 (all parts) API/Std 660 API/Std 661 API/Std 662
	Heaters and boilers	HB	A.2.3.3	ISO 13703 ISO 15649 API/Std 560
	Loading arms	LA	No	ISO 28460 ISO 16904
	Onshore pipelines	PL	No	ISO 13623
	Piping	PI	A.2.3.5	ISO 13703 ISO 15649 ASME B31.3
	Pressure vessels	VE	A.2.3.4	ASME VIII Div.1/2
	Silos	SI	No	
	Steam ejectors	SE	No	
	Storage tanks ^h	TA	A.2.3.9	ISO 28300 API Spec 12D API Spec 12F API Spec 12P API/Std 650 API/Std 620 API/Std 2000 API/Std 2610
	Swivels	SW	A.2.3.8	
	Turrets	TU	A.2.3.7	
	Winches	WI	A.2.3.6	

Table A.4 (continued)

Equipment category	Equipment class — Level 6	Equipment class code	Example included in Annex A	References
Electrical (A.2.4)	Frequency converters	FC	A.2.4.4	IEC 61800-1 IEC 61800-2 IEC 61800-3 IEC 61800-4 IEC 61800-5-1 IEC 60146 IEEE/Std 1566
	Power cables and terminations (topside/onshore)	PC	No	CSA FT4 CSA/Std C68.3 ICEA S-93-639-2000 IEC 60227 IEEE 1202 NEMA 20C NEMA VE-1 NEMA VE-2 UL 1072 UL 1277 UL 1569 UL 2225 UL 2250
	Power transformers	PT	A.2.4.2	IEC 60076 IEC 60076-1 IEC 60076-2 IEC 60076-3 IEC 60076-4 IEC 60076-5 IEC 60076-7 IEC 60076-8 IEC 60076-10 IEC 60076-11 IEC 60076-12 CAN/CSA C88-M IEEE C57.12.10 IEEE C57.18.10

Table A.4 (continued)

Equipment category	Equipment class — Level 6	Equipment class code	Example included in Annex A	References
	Switchgear	SG	A.2.4.3	IEC 61439-1 IEC 60947 IEC 60947-2 IEC 60947-3 IEC 60947-4-1 IEC 62271-1 IEC 62271-100 IEC 62271-102 IEC 62271-200 IEEE C37.012 IEEE C37.13.1 IEEE C37.20.7
	Uninterruptible power supply	UP	A.2.4.1	IEC 61000-4-7 IEC 62040-2 IEC 62040-3 FCC 47 CFR 15 NEMA PE 1 NEMA PE 5 NEMA PE 7
Safety and control (A.2.5)	Control logic units	CL	A.2.5.3	ISO 10418 ISO 13702 IEC 61131 API RP 554 NORSOK S-001
	Emergency communication equipment ^j	EC	No	ISO 15544 IMO (SOLAS, MODU)
	Escape, evacuation and rescue ^o	ER	No	ISO 13702 ISO 15544 IMO (SOLAS, MODU, LSA) NORSOK S-001
	Fire and gas detectors	FG	A.2.5.1	ISO 10418 ISO 13702 IMO (SOLAS, MODU, FSS) NORSOK S-001
	Fire-fighting equipment	FF	No	ISO 13702 NORSOK S-001

Table A.4 (continued)

Equipment category	Equipment class — Level 6	Equipment class code	Example included in Annex A	References
	Flare ignition	FI	No	ISO 25457 API/Std 521 API/Std 537
	Inert-gas equipment	IG	No	IMO (SOLAS, MODU)
	Input devices	IP	A.2.5.2	ISO 10418 NORSOK I-001
	Lifeboats	LB	A.2.5.6	ISO 13702 ISO 15544 DNV-OS-E406 IMO, SOLAS: MSC.81 (70) IMO, SOLAS: MSC.48 (66) NORSOK R-002 NORSOK S-001 NORSOK U-100
	Nozzles	NO	A.2.5.5	NFPA 13 NFPA 15 NFPA 16
	Telecommunications	TC	No	IMO/COMSAR/ Circ.32 NORSOK T-001 NORSOK T-100
	Valves	VA	A.2.5.4	ISO 5208 ISO 13702 ISO 14313 API Spec 6D API/Std 520 API/Std 521 API/Std 526 API/Std 594 API/Std 609 ASME B16.34 NORSOK S-001
Subsea (A.2.6) ^r	Dry tree risers	DT	No	ISO 10423 API Spec 6A
	Risers	PR	A.2.6.3	API RP 17B API Spec 17J
	Subsea compressors	SC	No	
	Subsea diving equipment	SD	No	

Table A.4 (continued)

Equipment category	Equipment class — Level 6	Equipment class code	Example included in Annex A	References
	Subsea electrical power distribution	EP	A.2.6.5	
	Subsea flowlines	FL	No	ISO 13623 ISO 14313 ISO 14723 ISO 16708 DNV-OS-F101 DNV-RP-F116
	Subsea heat exchangers	SH	No	
	Subsea intervention ^p	CI	No	API RP 17H
	Subsea manifolds	MA	No	ISO 13628-15
	Subsea pipelines	SL	A.2.6.7	ISO 13623 ISO 14313 ISO 14723 ISO 16708 DNV-OS-F101 DNV-RP-F116
	Submarine power cables	CA	No	IEC 60502 IEC 60840
	Subsea pressure vessels	SV	A.2.6.6	
	Subsea production control	CS	A.2.6.1	ISO 13628-5 API/Std 17F
	Subsea pumps	SP	A.2.6.4	
	Subsea templates	TM	No	ISO 13628-15
	Subsea wellhead and X-mas trees	XT	A.2.6.2	ISO 13628-4
Well completion ⁱ (A.2.7)	Downhole safety valves	SS	A.2.7.2 and A.2.7.5	ISO 10417 ISO 10432 ISO 16070 API RP 14B API Spec 14A API Spec 14L NORSOK D-010
	Downhole well completion ^q	WE	A.2.7.2	See also note ^q
	Electrical submersible pumps ^d	ESP	A.2.7.2 and A.2.7.6	ISO 15551-1 API RP 11S
	Surface wellhead and X-mas trees	XD	A.2.7.7	ISO 10423 API Spec 6A
Drilling (A.2.8)	Cementing equipment	CG	No	
	Choke and manifolds	DC	No	
	Crown and travelling blocks	TB	No	
	Derrick ^b	DE	No	

Table A.4 (continued)

Equipment category	Equipment class — Level 6	Equipment class code	Example included in Annex A	References
	Diverters	DI	No	ISO 13354
	Drawworks	DW	No	
	Drilling and completion risers	DD	No	ISO 13624-1 ISO 13628-7
	Drill strings	DS	No	ISO 11961
	Mud-treatment equipment ^f	DM	No	
	Pipe handling equipment	DH	No	
	Riser compensators	DR	No	
	String-motion compensators	MC	No	
	Subsea blowout preventers (BOP)	BO	A.2.8.2	API Spec16A API Spec 16D API/Std 53
	Surface blowout preventers (BOP) ^a	BT	A.2.8.3	API Spec 16A API Spec 16D API/Std 53
	Top drives	TD	A.2.8.1	
Well intervention ^l (A.2.9)	Coiled tubing, surface equipment	W1	No	
	Coiled tubing, surface well control equipment	WC	A.2.9.1	NORSOK D-002
	Coiled tubing, work strings	W2	No	
	Coiled tubing, bottom-hole assemblies	W3	No	
	Snubbing, surface equipment	W1	No	
	Snubbing, work strings	W2	No	
	Snubbing, surface well control equipment	WC	A.2.9.1	NORSOK D-002
	Snubbing, pipes and bottom hole assemblies	W3	No	
	Subsea well intervention ^e	OI	A.2.9.2	ISO 13628-7
	Wireline, surface equipment	W1	No	
	Wireline, surface well control equipment ⁿ	WC	A.2.9.1	NORSOK D-002
	Wireline, slick lines, braided cables and electric cables	W2	No	
	Wireline, bottom-hole assemblies	W3	No	
Marine (A.2.10)	Anchor windlasses and mooring equipment	AM	No	
	De-icing equipment ^k	IC	No	
	Dynamic positioning equipment	DP	No	ISO 19901-7
	Helicopter deck with equipment	HT	No	NORSOK C-004
	Jacking and fixation	JF	A.2.10.1	
	Marine disconnection equipment	MD	No	
	Thrusters	TH	No	
	Towing equipment	TO	No	

Table A.4 (continued)

Equipment category	Equipment class — Level 6	Equipment class code	Example included in Annex A	References
Utilities ^c (A.2.11)	Air-supply equipment	AI	No	
	De-superheaters	SU	No	
	Flare ignition equipment	FE	No	
	Heating/cooling media	HC	No	
	Hydraulic power units	HP	No	
	Nitrogen-supply equipment	NI	No	
	Open /Close drain equipment	OC	No	

Table A.4 (continued)

Equipment category	Equipment class — Level 6	Equipment class code	Example included in Annex A	References
Auxiliaries (A.2.12)	HVAC equipment ^m	HV	No	ISO 15138
a	Surface blowout preventers does not include land rig BOP.			
b	Including heave compensation.			
c	Utilities may be associated with a number of equipment classes in this International Standard (e.g. pumps, valves, instrumentation).			
d	Artificial lift equipment like Hydraulic submersible pumps (HSP), Progressive cavity pumps (PCP) and Gas lift valves (GLV) are not included here. See also A.2.7.2 and also A.2.7.6.			
e	Includes three equipment classes, and cover equipment such as e.g. workover riser.			
f	Includes shale shaker, desander/desilter, centrifuge and degasser.			
g	Does not include air compressor.			
h	Does not include offshore storage tanks.			
i	Well completion covers both surface and subsea completed wells. Wellhead is not an equipment class, but is a subunit in the Surface wellhead and X-mas trees (A.2.7.7) and in Subsea wellhead and X-mas tree (A.2.6.2), also since wellhead and X-mas tree acts as one barrier. A.2.7.2 describes the downhole well completion equipment and some overview of equipment classes that have been further subdivided, see A.2.7.5-6.			
j	Emergency communication would include Public announcement and communication system (PACOS) and associated equipment.			
k	This could include e.g. heat tracing equipment.			
l	Well intervention equipment classes are for dry well completions. In some data collection and exchange, the equipment classes might be gathered as four equipment classes (W1, W2, W3 and WC), and applicable for Coiled tubing, Wireline or Snubbing. See further information in A.2.9.1.			
m	The equipment classes that are relevant parts of a HVAC system are: 1) Motor driven blower fan. The blower fan unit can be covered by the equipment class Blowers and fans. 2) The driver will typically be covered by the existing equipment class Electric motors. 3) Filter can be covered by the equipment class Filters and strainers. 4) Heater/cooler. The heater/cooler unit can be included within the equipment class Heat exchangers. 5) Fire-, gas- and heat-detectors as equipment class Fire and gas detectors, 6) Input devices as equipment class Input devices.			
n	Note that the Wireline BOP is part of this.			
o	Lifeboat is established as a separate equipment class, but other equipment like Man-overboard boats (MOB) is not part of that equipment class. Various equipment will fulfil the functions needed for escape, evacuation and rescue. These could be related to transport, personal protective and life support, emergency communication, emergency utilities (lighting, power and ventilation) and ingress/egress/infrastructure (shelters, escape routes, doors, muster areas and landing areas, etc.). Some of this equipment can require reliability data collection and some would be covered by other equipment classes in Table A.4 .			
p	This includes remote operated tools (ROT), tie-in tools, running tools and remote operated vehicle (ROV) tools – as used for initial installation, subsea commissioning, intervention for repairs (e.g. SCM, subsea valves) or modification/extensions.			
q	Downhole well completion equipment class could be further subdivided, as done for some equipment class defines as DHSV and ESP. Standards relevant for casing and tubing (ISO 13679:2002, API Spec 5CT, ISO 11960:2014), Liner hanger packers (ISO 14310:2008 and NORSOK D-010:2013), Production packers (ISO 14310:2008), Flow control device (API Spec 19G2) and Downhole control and monitoring mandrels (ISO 14998:2013).			
r	ISO 13628-1:2005 applies for all subsea production systems in general.			

A.2 Equipment-specific data

A.2.1 General

Those equipment classes, indicated to have an example from the last column of [Table A.4](#), are presented in A.2.2 to A.2.12 and include a detailed description of the following:

- equipment-type classification;
- boundary definitions;
- subdivision into lower indenture levels;
- equipment-specific data.

This information should be used to identify the data necessary to be collected for each equipment example presented and define the structure for a database for the relevant taxonomic elements. Many of the recommended parameters can be common across many equipment classes (e.g. capacity, rotational speed). The examples should not be considered exhaustive. The equipment specific data can be either static or time dependent. Note that [Table 5](#) contain equipment data common to all equipment classes, and appropriate data therein comes always in addition to the equipment specific data suggested in A.2.

Examples of failure coding, such as failure modes, failure mechanism, failure cause, etc., are given in [Annex B](#). For safety equipment, some specific failure definitions are given in Annex F.

A.2.2 Rotating equipment data

A.2.2.1 Combustion engines

Table A.5 — Type classification — Combustion engines

Equipment class — Level 6		Equipment type	
Description	Code	Description	Code
Combustion engines	CE	Diesel engine	DE
		Otto (gas) engine	GE

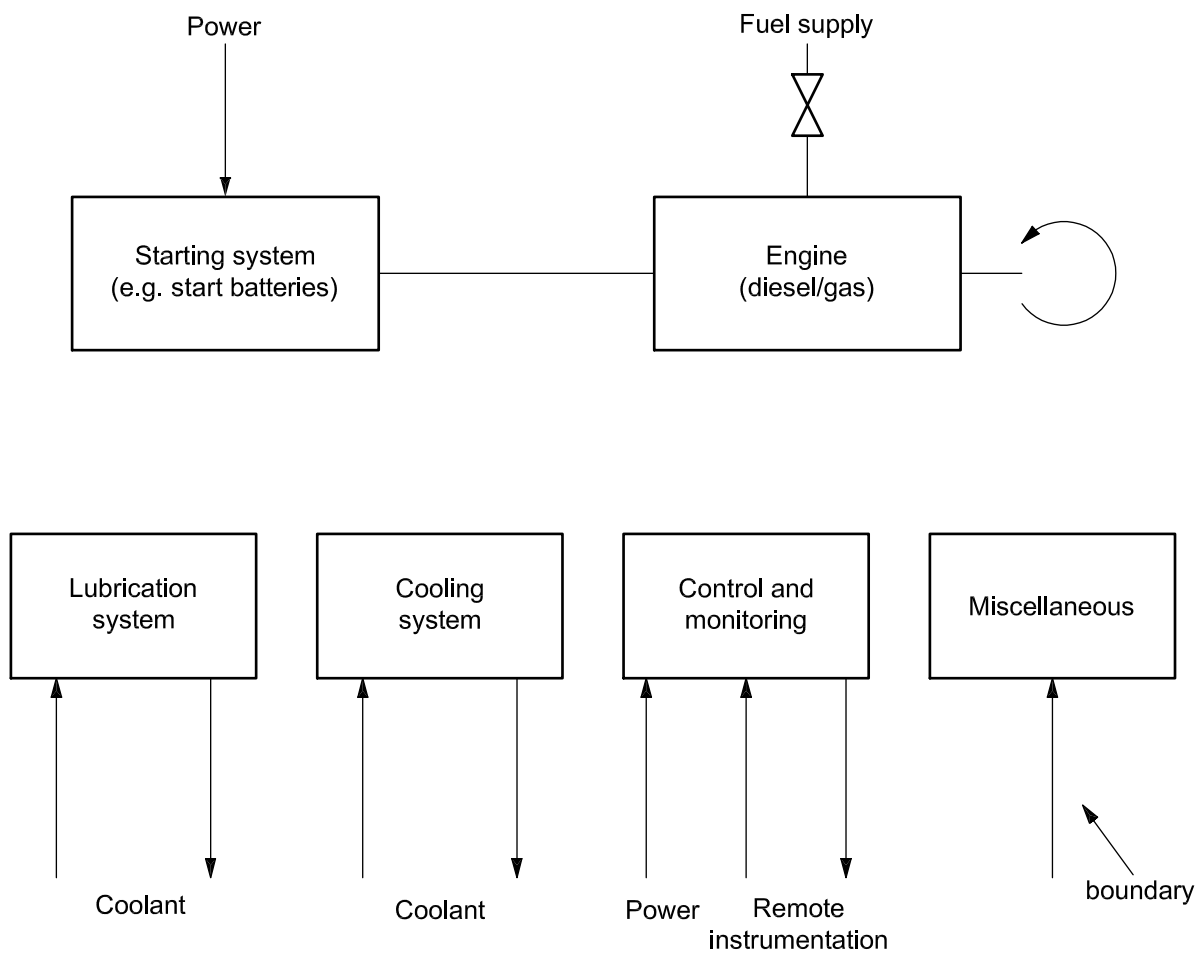

Figure A.2 — Boundary definition — Combustion engines

Table A.6 — Equipment subdivision — Combustion engines

Equip-ment unit	Combustion engines						
Subunit	Start system	Combustion engine unit	Control and monitoring	Lubrication system	Cooling system ^a	Miscellaneous	
Maintainable items	Start energy (battery, air)	Air inlet	Actuating device	Reservoir	Heat exchanger	Hood Flange joints	
	Starting unit	Ignition system	Control unit	Pump	Fan		
	Start control	Turbocharger	Fuel pumps	Internal power supply	Motor		Motor
		Injectors	Fuel filters	Monitoring	Filter		Filter
		Exhaust	Cylinders	Sensors ^b	Cooler		Valves
		Pistons	Shaft	Valves	Valves		Piping
		Thrust bearing	Radial bearing	Wiring	Piping		Pump
		Radial bearing	Seals	Piping	Oil		Temperature-control sensor
		Seals	Piping	Seals	Temperature-control sensor		
		Piping	Valves				
		Valves					
^a	Can include water-cooled or air-cooled systems.						
^b	Specify type of sensor, e.g. pressure, temperature, level, etc.						

Table A.7 — Equipment-specific data — Combustion engines

Name	Description	Unit or code list	Priority
Driven unit	Driven unit (equipment class, type and identification code)	Specify	High
Power - design	Maximum rated output (design)	Kilowatt	High
Power - operating	Specify the approximate power at which the unit has been operated for most of the surveillance time	Kilowatt	High
Speed	Design speed	Revolutions per minute	High
Number of cylinders	Specify number of cylinders	Integer	Low
Cylinder configuration	Type	Inline, vee, flat	Low
Starting system	Type	Electric, hydraulic, pneumatic	Medium
Ignition system	Otto, diesel	Compression ignition (diesel), spark plugs	Medium
Fuel	Type	Gas, light oil, medium oil, heavy oil, dual	Low
Air-inlet filtration type	Type	Free text	Low
Engine-aspiration type	Type of engine aspiration	Turbo, natural	Medium

A.2.2.2 Compressors

Table A.8 — Type classification — Compressors

Equipment class — Level 6		Equipment type	
Description	Code	Description	Code
Compressors ^a	CO	Centrifugal	CE
		Reciprocating	RE
		Screw	SC
		Axial	AX
^a Includes also air compressors.			

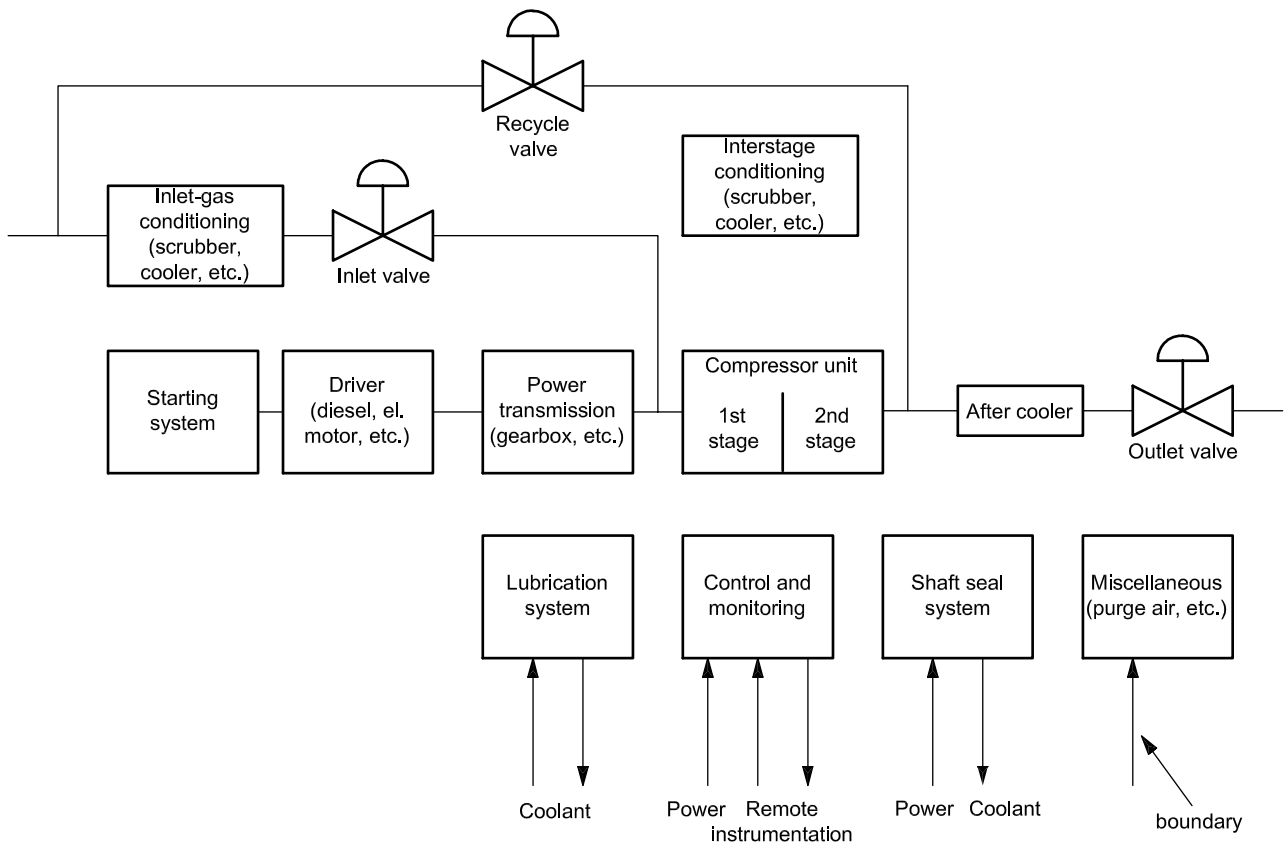

Figure A.3 — Boundary definition — Compressors

A.2.2.2.1 Equipment boundary definition for compressors

Figure A.2 shows the boundary definition for compressors. Inlet and outlet valves, and the compressor driver with connected auxiliaries, are not included within the boundary. Driver units are recorded as separate inventories (electric motor, gas turbine or combustion engine) and the failures on the driver, if recorded, should be recorded separately for the driver. A number in the compressor inventory shall give a reference to the appropriate driver inventory.

Compression is normally done in stages where a number of subunits are connected into a train.

A compressor train is considered as one inventory. Each compressor train can consist of up to four compressor stages. Recompression trains on an offshore oil platform normally perform compression in four stages. Each compression stage is usually performed by one compressor unit (casing) but in some cases one compressor unit can perform two stages. Each compressor (stage) normally contains several impellers that are the physical assembly of rotating blades that raise the pressure one step in the compressor unit.

If there are subunits that are common to the driver (e.g. a gas turbine) and the driven unit (i.e. the compressor), these are regarded as a part of the driven unit. For compressors with common lubrication-oil and seal-oil systems, failures should, as a general rule, be assigned to the subunit that is assumed to be the one most affected. Otherwise, the failure should be assigned to the lubrication-oil system.

Table A.9 — Equipment subdivision — Compressors

Equipment unit	Compressors					
Subunit	Power transmission	Compressor	Control and monitoring	Lubrication system	Shaft seal system	Miscellaneous
Maintainable items	Gearbox/ variable drive Bearings Belt/sheave Coupling to the driver Coupling to the driven unit Lubrication Seals	Casing Rotor with impellers Balance piston Interstage seals Radial bearing Thrust bearing Shaft seals Internal piping Valves Antisurge system ^b Piston Cylinder liner Packing	Actuating device Control unit Cables and junction boxes Internal power supply Monitoring Sensors ^a Valves Wiring Piping Seals	Oil tank with heating system Pump Motor Check valves Coolers Filters Piping Valves Lube oil	Oil tank with heating Reservoir Pump Motor Gear Filters Valves Seal oil Dry gas seal Mechanical seal Scrubber	Base frame Piping, pipe support and bellows Control valves Isolation valves Check valves Coolers Silencers Purge air Magnet- ic-bearing control system Flange joints
^a	Specify type of sensor, e.g. pressure, temperature, level, etc.					
^b	Including recycle valves and controllers.					

Table A.10 — Equipment-specific data — Compressors

Name	Description	Unit or code list	Priority
Compressed medium	Gas or air compressor	Gas, air	High
Type of driver	Driver unit (equipment class, type and identification code)	Specify	High
Gas handled	Average molar mass (specific gravity × 28,96)	Grams per mole	Medium
Suction pressure	Design – first stage	Pascal (bar)	Medium
Suction pressure	Operating – first stage	Pascal (bar)	Low
Discharge pressure	Design – last stage	Pascal (bar)	High
Discharge pressure	Operating – last stage	Pascal (bar)	Medium
Flow rate	Design	Metres cubed per hour	High
Flow rate	Operating	Metres cubed per hour	Low
Discharge temperature	Design	Degrees Celsius	Medium
Discharge temperature	Operating	Degrees Celsius	Low
Power	Design power	Kilowatt	High
Utilization	Percent utilization compared to design	Percent	Medium

Table A.10 (continued)

Name	Description	Unit or code list	Priority
Polytropic head	—	Kilojoules per kilogram	Low
Number of casings	Number of casings in the train	Integer	High
Number of stages	Number of compressor stages (not impellers) in this train	Integer	Medium
Body type	Type	Vertical split case (barrel type), axial split case	Low
Shaft sealing	Type	Mechanical, oil, dry gas-packed, dry gland, labyrinth, combined	Low
Intercooler fitted	Specify if cooler is fitted	Yes/no	Medium
Shaft seal system	Separate, combined, dry, etc.	Separate, combined, dry	High
Radial bearing	Type	Antifrictional, journal, magnetic	Low
Thrust bearing	Specify as relevant in comment field whether any thrust pressure regulator is installed	Antifrictional, journal, magnetic	Low
Speed	Design speed	Revolutions per minute	Low
Coupling	Type	Fixed, flexible, hydraulic, disconnect	Low
Reciprocating compressors only			
Cylinder configuration	—	Inline, opposed, V, W	Low
Cylinder orientation	—	Horizontal, vertical, inclined	Low
Working principle	—	Single-acting, double-acting	Low
Packing type	—	Lubricated, dry	Low

A.2.2.3 Electric generators

Table A.11 — Type classification — Electric generators

Equipment class — Level 6		Equipment type	
Description	Code	Description	Code
Electric generators	EG	Gas-turbine driven	TD
		Steam-turbine driven	SD
		Turboexpander	TE
		Engine driven, e.g. diesel engine, gas engine	MD

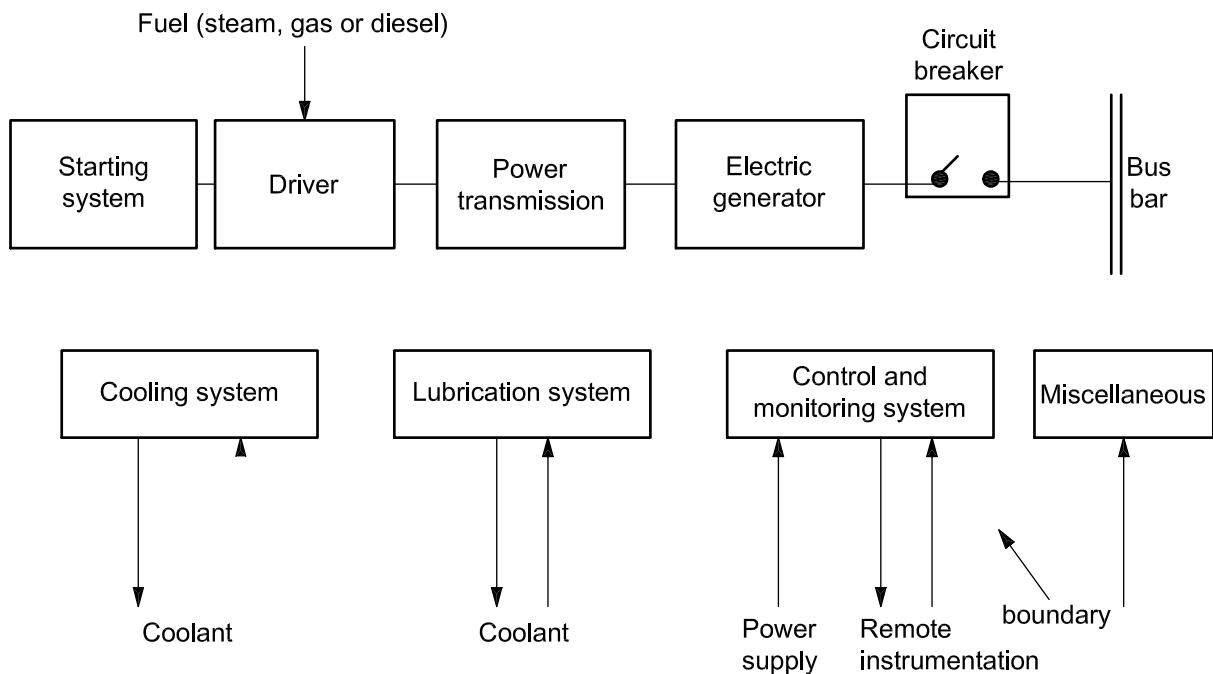

Figure A.4 — Boundary definition — Electric generators

Table A.12 — Equipment subdivision — Electric generators

Equipment unit	Electric generators					
Subunit	Power transmission	Electric generator	Control and monitoring ^a	Lubrication system	Cooling system	Miscellaneous
Maintainable items	Gearbox Radial bearing Thrust bearing Seals Lubrication Coupling to driver Coupling to driven unit Belt/sheave	Stator Rotor Radial bearing Thrust bearing Excitation Cabling and junction boxes	Actuating device Control unit (e.g. AVR) Internal power supply Monitoring Sensors ^b Valves Wiring Piping Seals	Reservoir Pump Motor Filter Cooler Valves Piping Oil	Heat exchanger Fan Motor Filter Valves Piping Pump	Hood Purge air Neutral grounding resistors (NGRs) ^c
<p>^a The automatic voltage regulator (AVR) is an element within “Control”. Temperature and vibration surveillance are elements within “Monitoring”.</p> <p>^b Specify type of sensor, e.g. pressure, temperature, level, etc.</p> <p>^c Depending on the earthing philosophy.</p>						

Table A.13 — Equipment-specific data — Electric generators

Name	Description	Unit or code list	Priority
Type of driver	Equipment class, type and identification code	Specify	High
Coupling	Specify (fixed, flexible, etc.)	Fixed, flexible, hydraulic, disconnect	Low
Speed	Synchronous	Revolutions per minute	Medium
Frequency	Design frequency	Hertz	Low
Voltage	Design voltage	Kilovolts	High
Power – design	Design power	Kilovolts	High
Power factor	$\cos\varphi$	Number	Low
Excitation control	Type	Automatic, manual	Medium
Excitation type	Brushless/slip-ring	Brushless, slip-ring	Medium
Degree of protection	Protection class in accordance with IEC 60529	IP	Low
Insulation class – stator	Insulation class in accordance with IEC 60034-1	Y, A, E, B, F, H	Medium
Temperature rise – stator	Temperature rise in accordance with IEC 60034-1	Y, A, E, B, F, H	Low
Insulation class – rotor	Insulation class in accordance with IEC 60034-1	Y, A, E, B, F, H	Medium
Temperature rise – rotor	Temperature rise in accordance with IEC 60034-1	Y, A, E, B, F, H	Medium
Radial bearing	Type	Antifrictional, journal, magnetic	Low
Thrust bearing	Type	Antifrictional, journal, magnetic	Low
Lubrication of bearings	Type of bearing lubrication	Grease, oil bath, pressurized oil, oil ring	Low
Generator cooling	Type	Air/air, air/water, open ventilated	Low

A.2.2.4 Electric motors**Table A.14 — Type classification — Electric motors**

Equipment class — Level 6		Equipment type	
Description	Code	Description	Code
Electric motors	EM	Alternating current	AC
		Direct current	DC

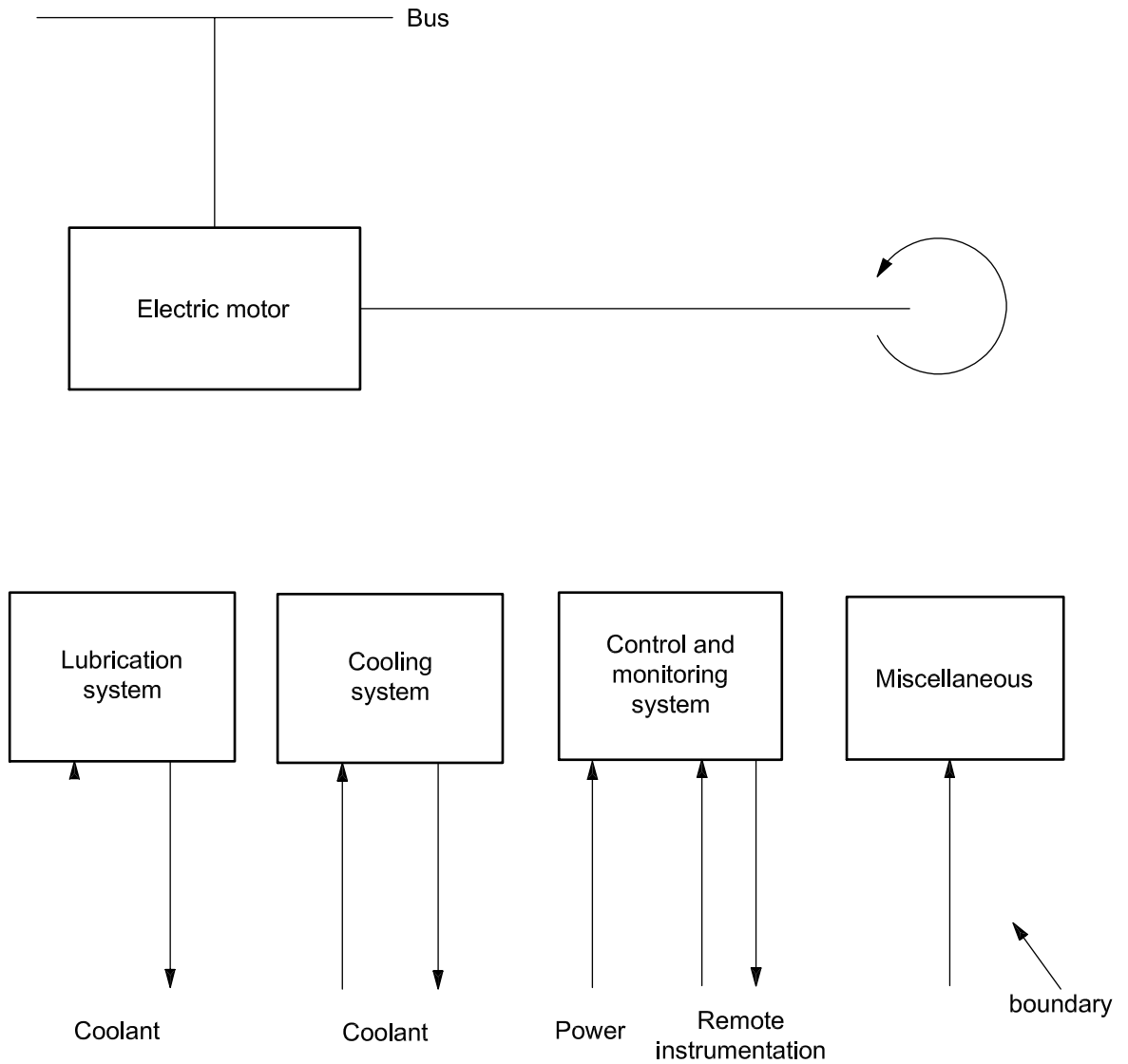

Figure A.5 — Boundary definition — Electric motors

Table A.15 — Equipment subdivision — Electric motors

Equipment unit	Electric motors				
Subunit	Electric motor ^c	Control and monitoring ^a	Lubrication system	Cooling system	Miscellaneous
Maintainable items	Stator	Actuating device	Reservoir	Heat exchanger	Hood
	Rotor	Control unit	Pump	Filter	
	Excitation	Internal power supply	Motor	Valves	
	Radial bearing	Monitoring	Filter	Piping	
	Thrust bearing	Sensors ^b	Cooler	Pump	
		Valves	Valves	Motor	
		Wiring	Piping	Fan	
		Piping	Oil		
	Seals				

^a Normally, there is no extra control system for motors. For motors of Ex(p) class (pressurized), the internal pressure is monitored. Temperature can be monitored on large motors.

^b Specify type of sensor, e.g. pressure, temperature, level, etc.

^c VFD is not included inside the electric motor boundary. See also A.2.4.4 and [Figure A.22](#) with respect to Variable Speed Drive System (VS DS).

Table A.16 — Equipment-specific data — Electric motors

Name	Description	Unit or code list	Priority
Type of driven unit	Equipment class, type and identification code	Specify	High
Power – design	Max. output (design)	Kilowatt	Medium
Power – operating	Specify the approximate power at which the unit has been operated for most of the surveillance time	Kilowatt	Low
Variable speed	Specify if installed or not	Yes/No	Low
Speed	Design speed	Revolutions per minute	Medium
Voltage	Design voltage	Volts	Medium
Motor type	Type	Induction, commutator (d.c.), synchronous	Medium
Insulation class – stator	Insulation class in accordance with IEC 60034-1	Y, A, E, B, F, H	Medium
Temperature rise – stator	Temperature rise in accordance with IEC 60034-1	Y, A, E, B, F, H	Low
Insulation class – rotor ^a	Insulation class in accordance with IEC 60034-1	Y, A, E, B, F, H	Medium
Temperature rise – rotor ^a	Temperature rise in accordance with IEC 60034-1	Y, A, E, B, F, H	Medium
Degree of protection	Protection class in accordance with IEC 60529	Specify	Medium
Type of Ex protection	Explosion classification category, e.g. Ex(d), Ex(e) ^b	e.g. Ex(d), Ex(e)	High

^a Not relevant for induction motors.

^b See IEC 60079 (all parts).

A.2.2.5 Gas turbines

Table A.17 — Type classification — Gas turbines

Equipment class — Level 6		Equipment type	
Description	Code	Description	Code
Gas turbines	GT	Industrial	IN
		Aero-derivative	AD
		Heavy duty	HD

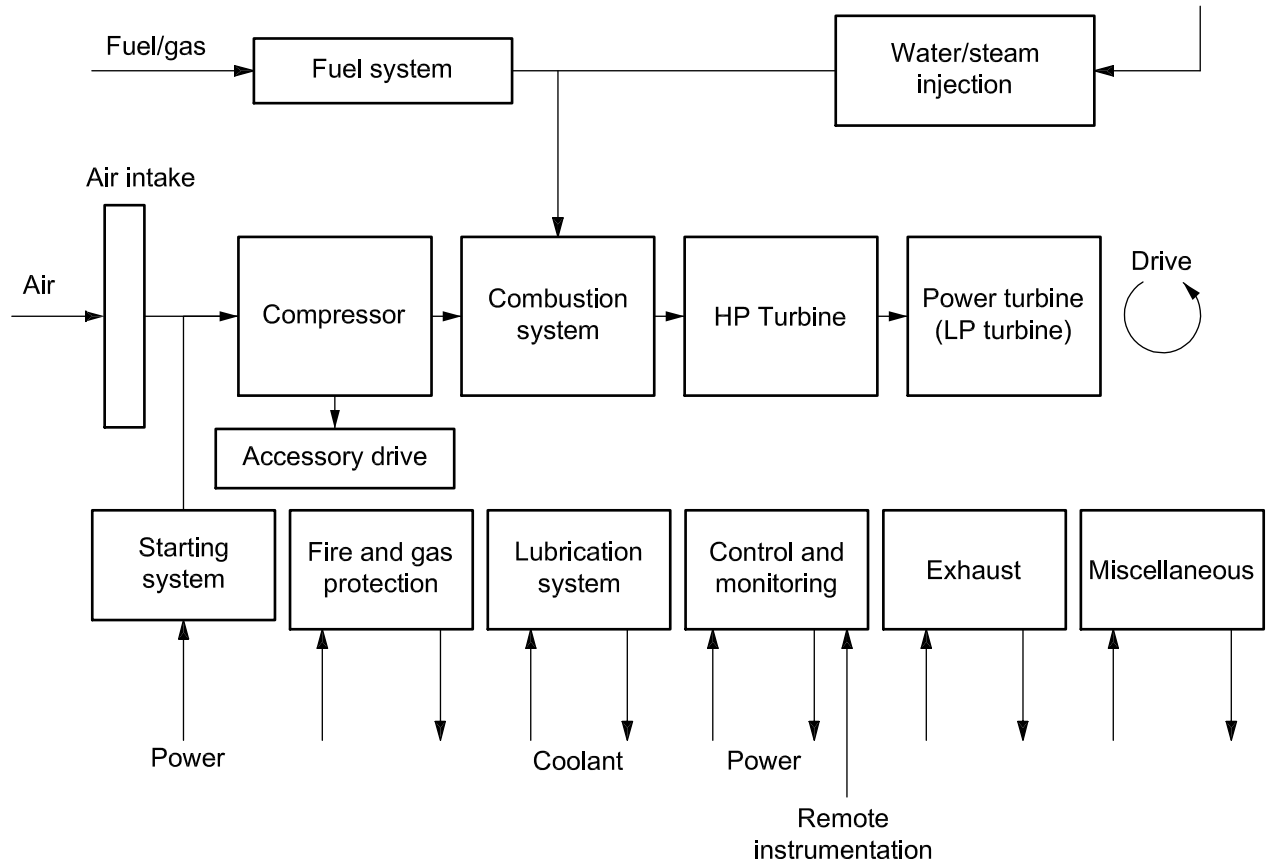

NOTE This boundary drawing shows a typical layout frequently used for mechanical drive or power generation. However, gas turbines can be configured in different ways with regards to the layout of some subsystems. The compressor and the turbine can be mechanically coupled, single-shaft GT. Other alternatives are when one or more parts of the turbine are mechanically decoupled (multi-spool GT).

Figure A.6 — Boundary definition — Gas turbines

Table A.18 — Equipment subdivision — Gas turbines

Equip-ment unit	Gas turbines						
Subunit	Starting system	Air intake	Combustion system	Compressor	Power turbine HP turbine	Control and monitoring	
Maintainable items	Starting motor	Air cooling	Combustor	Rotor	Rotor	Control unit	
	Start control	Anti-icing	Fuel nozzles	Stator	Stator	Sensors ^a	
	Piping	Filters	Seals	Cooling system	Casing	Wires	
	Filter(s)	Intake duct		VGV system	Radial bearing	Actuating devices	
	Valve(s)	Inlet vanes		Anti-surge valve	Thrust bearing	Monitoring	
	Pump(s)			Aux. bleeding system	Seals	Valves	
	Start energy (e.g. battery, air)			Anti-icing valve	Valves	Internal power supply	
				Casing	Piping	Seals	
				Radial bearing		—	
				Thrust bearing			
				Seals			
				Piping			
	Lubrication system	Fuel system	Water/Steam injection^b	Fire and gas protection	Accessory drive	Exhaust	Miscellaneous
	Heater	Fuel control	Pump(s)	Control unit	Gearbox	Diffuser	Enclosure
	Reservoir(s)	Piping	Piping	Pipes	Bearing	Exhaust collector	Hood
	Pump(s)	Valves	Valves	Valves	Seals		Purge air
	Motor	Seals	Filter(s)	Sensors	Casing	Compensator/bellows	Flange joints
	Filter	Pump(s)/Gas compressor	Seals	Wires		Ducting	Ventilation fan
	Temperature control	Filter(s)/Separators	Wires	Tank(s)/Storage		Emission monitoring	Water-wash system
	Valves	Wires				Silencer	
	Piping	Fuel properties measurement				Thrust bearing	
	Oil cooler					Valves	
	Oil					Waste heat recovery unit	
	Sensors						
	Wires						

^a Specify type of sensor, e.g. pressure, temperature, level, etc.

^b Only relevant for gas turbines with NO_x-abatement control with steam or water.

Table A.19 — Equipment-specific data — Gas turbines

Name	Description	Unit or code list	Priority
Type of driven unit	Characteristics of the driven subsystem	Generator drive, mechanical drive, auxiliaries, other	High
Power – design	ISO power rating	Kilowatt	High
Power – operating	Specify the approximate power at which the unit has been operated for most of the surveillance time.	Kilowatt	Medium
Operating profile	Utilization profile	Base load, peak load, load-sharing backup, emergency/reserve	High
De-rating	Specify if permanently de-rated or not	Yes/No	Medium
Speed	Design speed (power shaft)	Revolutions per minute	Medium
Number of shafts	Specify number	1, 2, 3	Medium
Starting system	Specify main starting system	Electric, hydraulic, pneumatic	High
Backup starting system	Specify if relevant	Electric, hydraulic, pneumatic	Low
Fuel	Fuel type	Gas, oil-light, oil-medium, oil-heavy, dual	Medium
NO _x abatement	Type of abatement control	Steam, water, dry (e.g. dry low emission), none (e.g. single annular combustor)	High
Air inlet filtration type	Type	Free text	Low

A.2.2.6 Pumps**Table A.20 — Type classification — Pumps**

Equipment class — Level 6		Equipment type	
Description	Code	Description	Code
Pumps	PU	Centrifugal	CE
		Reciprocating	RE
		Rotary	RO

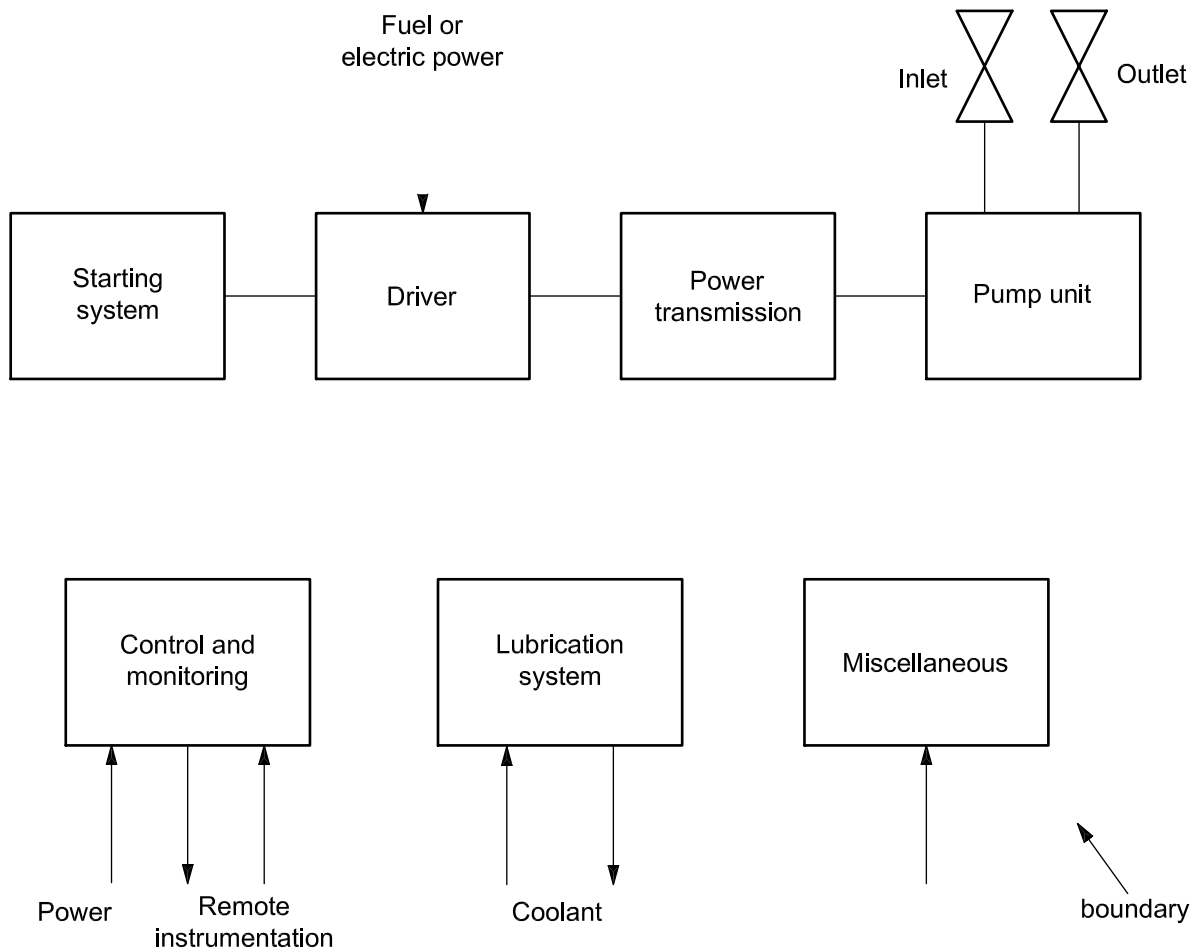

Figure A.7 — Boundary definition — Pumps

Table A.21 — Equipment subdivision — Pumps

Equipment unit	Pumps				
Subunit	Power transmission	Pump unit	Control and monitoring	Lubrication system	Miscellaneous
Maintainable items	Gearbox/ variable drive	Support	Actuating device	Reservoir	Purge air
	Bearing	Casing	Control unit	Pump	Cooling/heating system
	Seals	Impeller	Internal power supply	Motor	Cyclone separator
	Coupling to driver	Shaft	Monitoring	Filter	Pulsation damper
	Coupling to driven unit	Radial bearing	Sensors ^a	Cooler	Flange joints
	Belt/sheave	Thrust bearing	Valves	Valves	
		Seals	Wiring	Piping	
		Valves	Piping	Oil	
		Piping	Seals	Seals	
		Cylinder liner			
		Piston			
	Diaphragm				

^a Specify type of sensor, e.g. pressure, temperature, level, etc.

Table A.22 — Equipment-specific data — Pumps

Name	Description	Unit or code list	Priority
Type of driver	Equipment class, type and identification code	Specify	High
Fluid handled	Type	Oil, gas, condensate, freshwater, steam, sea water, crude oil, oily water, flare gas, fuel gas, water/glycol, methanol, nitrogen, chemicals, hydrocarbon-combined, gas/oil, gas/condensate, oil/water, gas/oil/water, LNG, drilling mud, drilling cement, other	High
Fluid corrosive/erosive	Classify as shown in footnote ^a	Benign, moderate, severe	Medium
Application – pump	Where applied	Booster, supply, injection, transfer, lift, dosage, disperse, cooling, drilling, other	Medium
Pump – design	Design characteristic	Axial, radial, composite, diaphragm, plunger, piston, screw, vane, gear, lobe	High
Power – design	Design/rated power of pump	Kilowatt	High
Utilization of capacity	Normal operating/design capacity	Percent	Medium
Suction pressure – design	Design pressure	Pascal (bar)	Medium
Discharge pressure – design	Design pressure	Pascal (bar)	High
Speed	Design speed	Revolutions per minute or strokes per minute	Medium
Number of stages	Centrifugal: number of impellers (in all stages) Reciprocating: number of cylinders Rotary: number of rotors	Number	Low
Body type	Barrel, split casing, etc.	Barrel, split case, axial split, cartridge,	Low
Shaft orientation	—	Horizontal, vertical	Low
Shaft sealing	Type	Mechanical, oil seal, dry gas, packed, gland, dry seal, labyrinth, combined	Low
Transmission type	Type	Direct, gear, integral	Low
Coupling	Coupling	Fixed, flexible, hydraulic, magnetic, disconnect	Low
Environment	Submerged or dry-mounted	—	Medium
Pump cooling	Specify if separate cooling system is installed	Yes/No	Low
Radial bearing	Type	Antifrictional, journal, magnetic	Low
Thrust bearing	Type	Antifrictional, journal, magnetic	Low
Bearing support	Type	Overhung, between bearings, pump casing, split sleeve	Low
^a Benign (clean fluids, e.g. air, water, nitrogen). Moderately corrosive/erosive (oil/gas not defined as severe, sea water, occasionally particles). Severely corrosive/erosive [sour gas/oil (high H ₂ S), high CO ₂ , high sand content].			

A.2.2.7 Steam turbines

Table A.23 — Type classification — Steam turbines

Equipment class — Level 6		Equipment type	
Description	Code	Description	Code
Steam turbines	ST	Multi-stage	MS
		Single-stage	SS

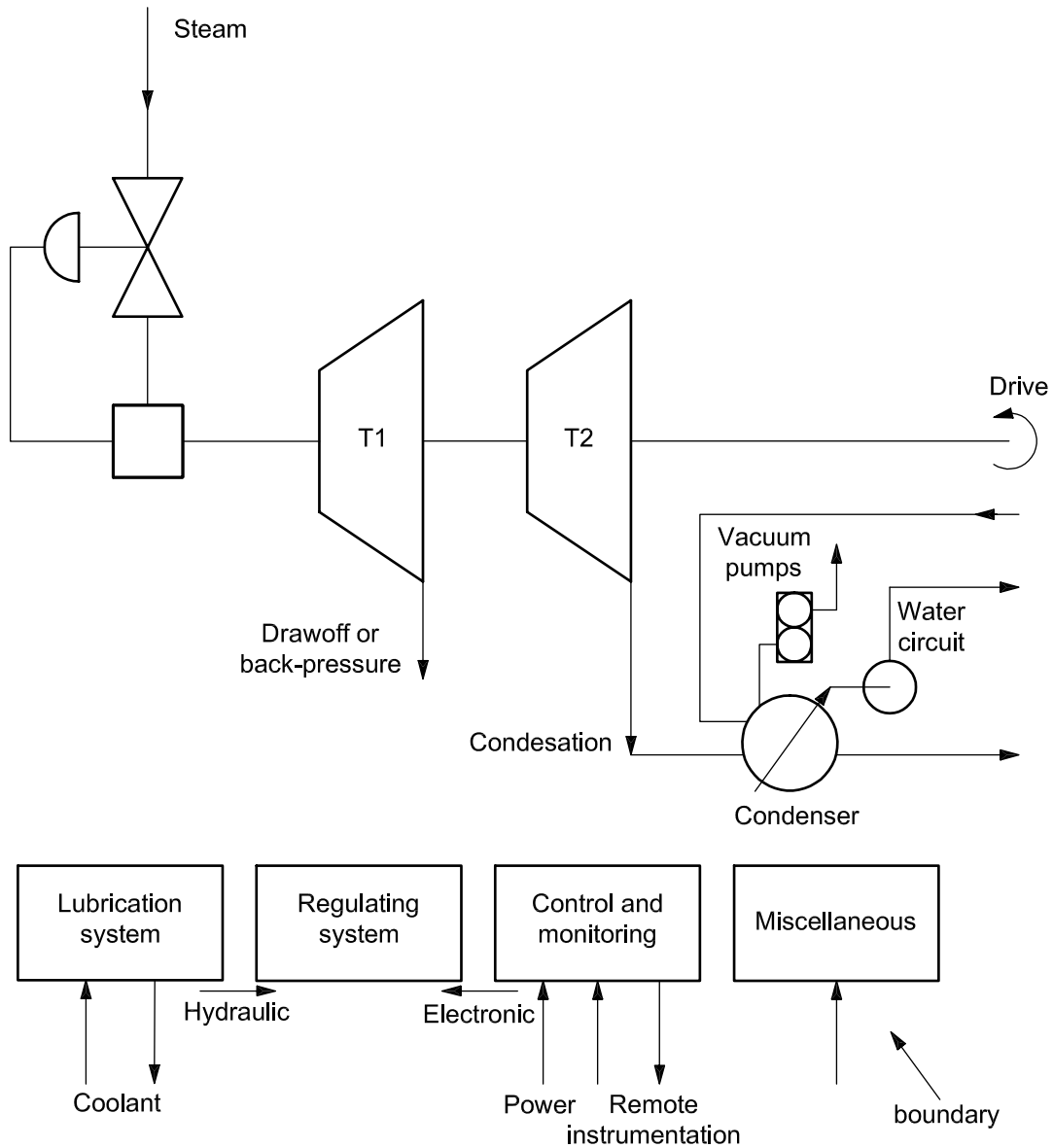

Key

- T1 turbine stage 1
- T2 turbine stage 2

Figure A.8 — Boundary definition — Steam turbines

Table A.24 — Equipment subdivision — Steam turbines

Equipment unit	Steam turbines					
Subunit	Power turbine	Condenser	Regulating system	Lubrication system	Control and monitoring	Miscellaneous
Maintainable items	Piping Radial bearing Rotor Seals Stator/casing Steam reg. valves Thrust bearing	Condenser Reg. pump Vacuum pump	Filter Pump	Cooler Filter Oil Oil seal pump Piping Pump Motor Reservoir Valves	Actuating device Control unit Internal power supply Monitoring Sensors ^a Valves Wiring Piping Seals	Cranking system Hood
^a	Specify type of sensor, e.g. pressure, temperature, level etc.					

Table A.25 — Equipment-specific data — Steam turbines

Name	Description	Unit or code list	Priority
Driven unit	Equipment class, type and identification code	Compressor, crane, generator, pump, winch, etc.	High
Power – design	ISO power rating	Kilowatt	High
Power – operating	Specify the approximate power at which the unit has been operated for most of the surveillance time.	Kilowatt	Medium
Speed	Design speed (power shaft)	Revolutions per minute	Medium
Number of shafts	Specify number	Number	Medium
Regulating system	Specify type	Electronic, hydraulic	Medium
Backup starting system	Specify if relevant	Electric, hydraulic, pneumatic	Low
Fuel	Fuel type	Gas, oil-light, oil-medium, oil-heavy, dual	Medium
Air inlet filtration type	Type	Free text	Low

A.2.2.8 Turbo expanders

Table A.26 — Type classification — Turbo expanders

Equipment class — Level 6		Equipment type	
Description	Code	Description	Code
Turbo expanders	TE	Centrifugal	CE
		Axial	AX

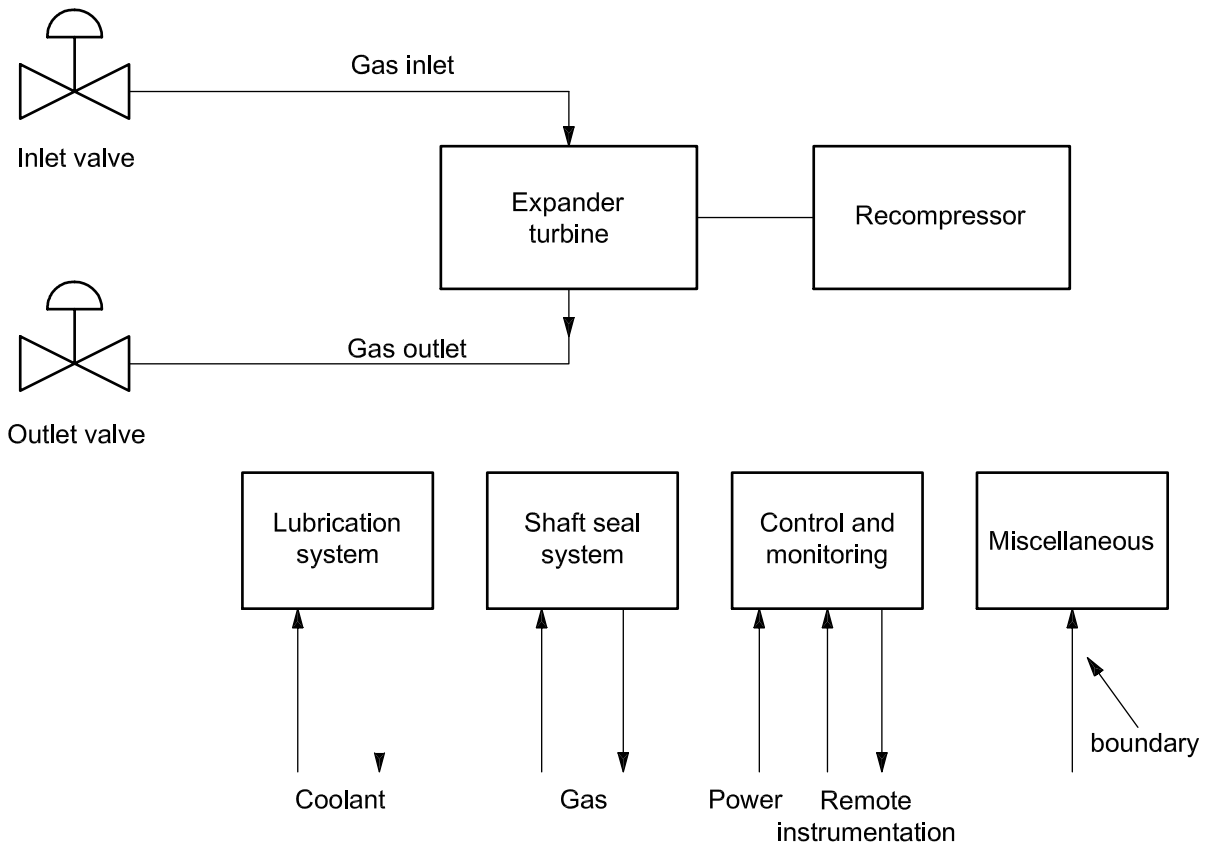

NOTE Driven units other than recompressors (e.g. pumps or generators) are also outside the boundary.

Figure A.9 — Boundary definition — Turbo expanders

Table A.27 — Equipment subdivision — Turbo expanders

Equipment unit	Turbo expanders				
Subunit	Expander turbine	Control and monitoring	Lubrication system	Shaft seal system	Miscellaneous
Maintainable items	Rotor w/impellers Inlet vanes Casing Radial bearing Thrust bearing Seals Inlet screen Valves Piping	Actuating device Control unit Internal power supply Monitoring Sensors ^a Valves Wiring Piping Seals	Reservoir Pump Motor Filter Cooler Valves Piping Oil	Seal-gas equipment Seal gas	Others
^a Specify type of sensor, e.g. pressure, temperature, level, etc.					

Table A.28 — Equipment-specific data — Turbo expanders

Name	Description	Unit or code list	Priority
Type of driven unit	Equipment class, type and identification code	Specify	High
Power – design	Max. design output power	Kilowatt	High
Power – operating	Specify the approximate power at which the unit has been operated for most of the surveillance time.	Kilowatt	Low
Speed	Design speed	Revolutions per minute	Medium
Inlet flow	Design inlet flow, turbine	Kilograms per hour	Medium
Inlet temperature	Design inlet temperature, turbine	Degrees Celsius	Medium
Inlet pressure	Design inlet pressure, turbine	Pascal (bar)	Medium
Gas handled	Average molar mass (specific gravity × 28,96)	Grams per mole	Low
Gas corrosiveness/erosiveness	Specify as shown in the footnote ^a	Benign, moderate, severe	Medium
Type of design	Type	Centrifugal, axial	Medium
Number of stages	Number of stages (in series)	Number	Low
Casing-split type	Type	Horizontal/vertical	Low
Shaft sealing	Type	Mechanical, oil seal, dry gas, packed gland, dry seal, labyrinth, combined	Low
Flow-control turbine	Type	Variable nozzles, nozzle-group valves, throttle valve, fixed inlet	Low
Radial bearing	Type	Antifrictional, journal, magnetic	Low
Thrust bearing	Type	Antifrictional, journal, magnetic	Low
^a Benign (clean and dry gas). Moderately corrosive/erosive (some particles or droplets, some corrosiveness). Severe corrosive/erosive (sour gas, high CO ₂ content, high content of particles).			

A.2.3 Mechanical equipment

A.2.3.1 Cranes

Table A.29 — Type classification — Cranes

Equipment class — Level 6		Equipment type	
Description	Code	Description	Code
Cranes	CR	Electro-hydraulic operated	HO
		Diesel hydraulic operated	DO

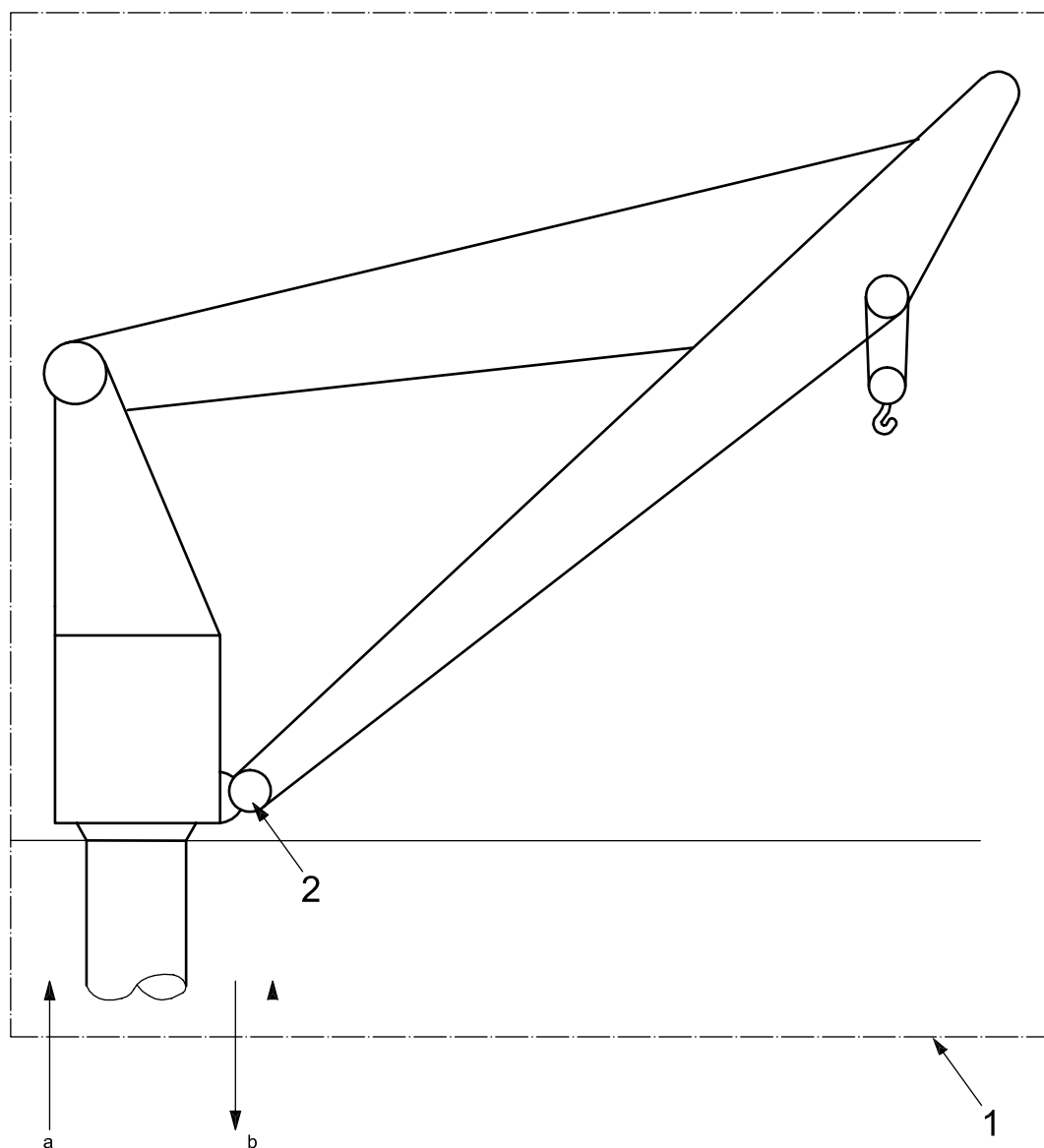

Key

- 1 boundary
- 2 crane base (u/s slew ring)
- a Power supply.
- b Communication signal in/out.

NOTE The boundary drawing illustrates one type of crane commonly used offshore. Several other categories exist, viz. traversing cranes, gantry cranes etc. It is necessary to adapt the taxonomy for these categories to each category.

Figure A.10 — Boundary definition — Cranes

Table A.30 — Equipment subdivision — Cranes

Equipment unit	Cranes						
Subunit	Crane structure	Boom system	Hoist system	Swing system	Power system	Control and monitoring	Miscellaneous
Maintainable items	A-frame/king Drivers cabin Engine room Pedestal Crane frame	Boom Boom bearing Hydraulic cylinder Luffing winch Luffing wire Luffing sheaves Boom stop cylinder	Hoist winch Hoist sheaves Hook Lifting wire Shock damper	Slew bearing Slew ring Slew motor Slew pinion	Hydraulic pumps Electric engine Diesel engine Proportional valves Hydraulic tank Hydraulic filters Hydraulic oil	PC/PLS Control valves Internal power supply Amplifiers Joysticks Load indicator	Others

Table A.31 — Equipment-specific data — Cranes

Name	Description	Unit or code list	Priority
Type of driver	Driver unit (equipment class, type and identification code)	Specify	High
Overall maximum height	Specify	Metres	Low
Main boom length	Specify	Metres	Medium
A-frame height	Specify	Metres	Low
Boom, min. angle	Specify	Degrees	Low
Boom, max. angle	Specify	Degrees	Low
Slew bearing type	Specify	Conical, roller	High
Hydraulic operating medium	Hydraulic fluid type	Oil-based, synthetic-based, water-based	Low
Hydraulic operating pressure	Specify	Pascal (bar)	Low
Total unit weight	Specify	Metric tonnes	Medium
Boom total weight	Specify	Metric tonnes	Low
Safe working load (SWL)	Crane's safe working load	Metric tonnes	High
Max. operating swing	Turning range (total)	Degrees	Medium
Max. moment	Crane's max. moment	Tonne-metre	High
Hoist speed 1	At max. load	Metres per second	Medium
Hoist speed 2	At no load	Metres per second	Low
Slewing speed 1	At max. load	Degrees per second	Medium
Slewing speed 2	At no load	Degrees per second	Low
WHIP crane	Installed or not	Yes/No	Low
Heave compensation system	Installed or not	Yes/No	Low

Table A.31 (continued)

Name	Description	Unit or code list	Priority
Automatic overload protection system (AOPS)	Installed or not	Yes/No	High
Manual overload protection system (MOPS)	Installed or not	Yes/No	High
Constant tension	Installed or not	Yes/No	Low

A.2.3.2 Heat exchangers

NOTE Heat exchangers include coolers, condensers and re-vaporizers, etc.

Table A.32 — Type classification — Heat exchangers

Equipment class — Level 6		Equipment type	
Description	Code	Description	Code
Heat exchangers	HE	Shell and tube	ST
		Plate	P
		Plate fin	PF
		Double pipe	DP
		Bayonet	BY
		Printed circuit	PC
		Air-cooled	AC
		Spiral	S
		Spiral-wound	SW

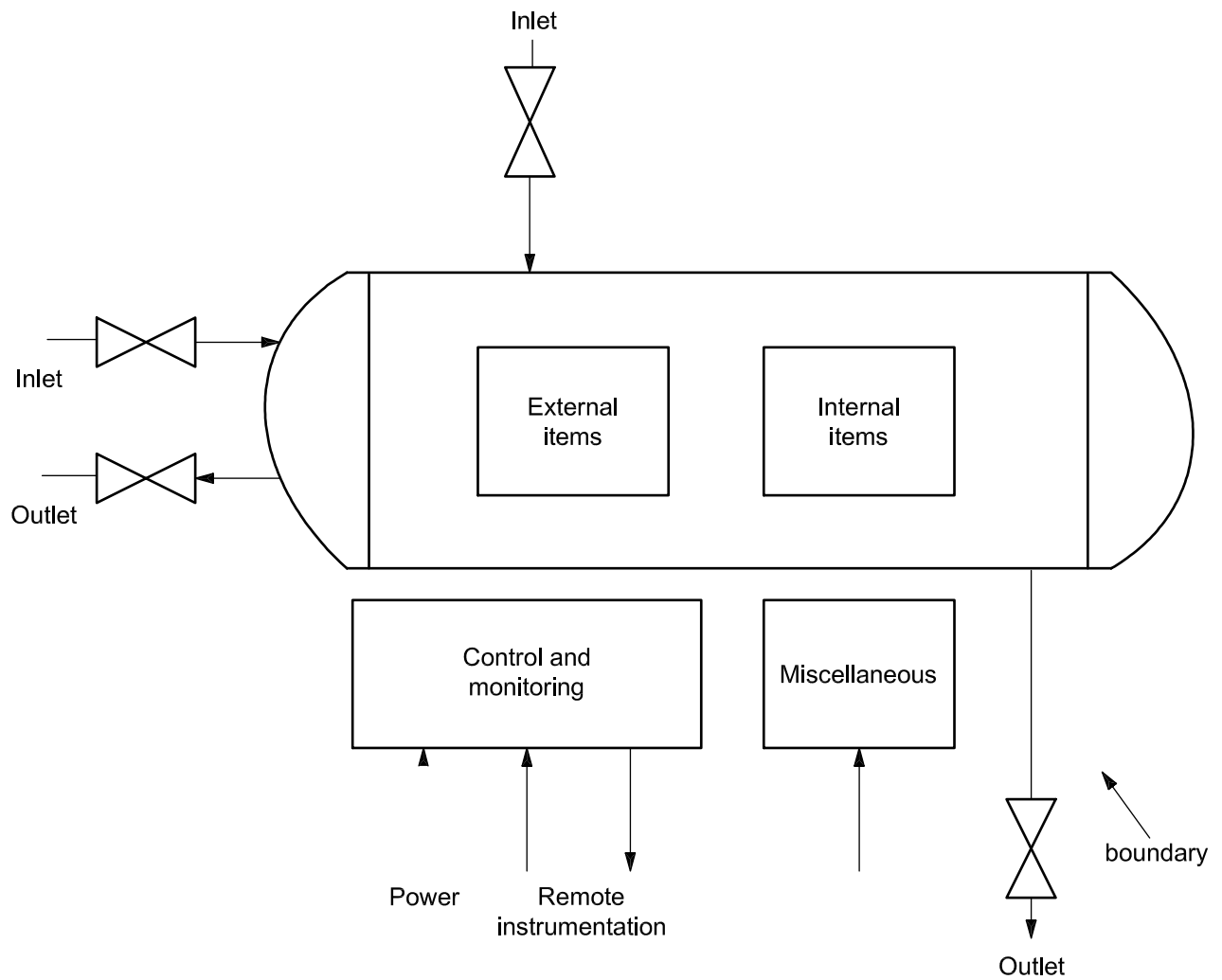

Figure A.11 — Boundary definition — Heat exchangers

Table A.33 — Equipment subdivision — Heat exchangers

Equipment unit	Heat exchangers			
Subunit	External	Internal	Control and monitoring	Miscellaneous
Maintainable items	Support Body/shell Valves Piping	Body/shell Tubes Plates Seals (gaskets)	Actuating device Control unit Internal power supply Monitoring Sensors ^b Valves Wiring Piping Seals	Fan ^a Motor
^a	Applicable for air-cooled heat exchangers only.			
^b	Specify type of sensor, e.g. pressure, temperature, level, etc.			

Table A.34 — Equipment-specific data — Heat exchangers

Name	Description	Unit or code list	Priority
Fluid, hot side	Fluid type	Oil, gas, condensate, freshwater, steam, sea water, crude oil, oily water, flare gas, water/glycol, methanol, nitrogen, chemicals, hydrocarbon, air	High
Fluid, cold side	Fluid type	Oil, gas, condensate, freshwater, steam, sea water, crude oil, oily water, flare gas, water/glycol, methanol, nitrogen, chemicals, hydrocarbon, air	High
Rated heat transfer	Design value	Kilowatt	Medium
Heat-transfer area	—	Metres squared	Medium
Utilization	Used/rated heat transfer	Percent	Medium
Pressure, hot side	Design pressure	Pascal (bar)	Medium
Pressure, cold side	Design pressure	Pascal (bar)	Medium
Temperature drop, hot side	Operating	Degrees Celsius	Low
Temperature rise, cold side	Operating	Degrees Celsius	Low
Size – diameter	External	Millimetres	Medium
Size – length	External	Metres	Medium
Number of tubes/plates	—	Number	Low
Tube/plate material	Specify material type in tubes/plates.	Free text	Medium

A.2.3.3 Heaters and boilers

A.2.3.3.1 Boundary definitions for heaters and boilers

The boundary definition applies to hydrocarbon- (HC-) fired heaters and boilers. The layout of heaters and boilers can vary considerably; however, they all apply the same principle supplying energy to heat or boil a medium. The energy can be supplied through combustion of hydrocarbons, through supply of a high-temperature medium (e.g. steam) or by electricity.

The heater and boiler components may vary significantly in design, but will typically include a vessel/shell in which the heating process is performed. For heaters and HC-fired boilers, a burner device and an exhaust system are included. Unlike most boilers, the heaters contain a tube coil through which the medium being heated flows.

For HC-fired heaters and boilers, the fuel-control valve is inside the equipment boundary, while the fuel-conditioning equipment (e.g. scrubbers) and ESD/PSD valves are outside the boundary.

Inlet, outlet, pressure-relief and drain valves are specifically excluded. Valves and instruments included are those locally mounted and/or which form a pressure boundary (e.g. block valves, calibration valves, local indicators/gauges).

Table A.35 — Type classification — Heaters and boilers

Equipment class — Level 6		Equipment type	
Description	Code	Description	Code
Heaters and boilers	HB	Direct-fired heater	DF
		Electric heater	EH
		Indirect HC-fired heater	IF
		Heater treater	HT
		Non-HC-fired boiler	NF
		Electric boiler	EB
		HC-fired boiler	FB

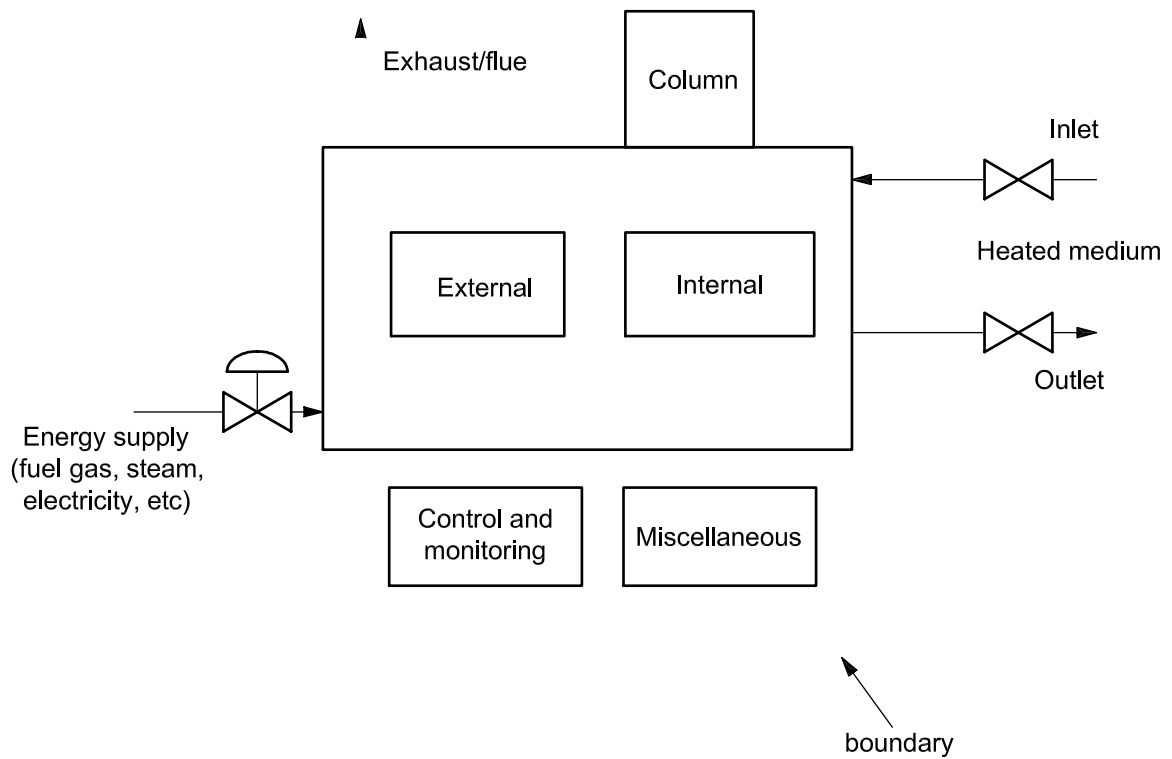

Figure A.12 — Boundary definition — Heaters and boilers

Table A.36 — Equipment subdivision — Heaters and boilers

Equipment unit	Heaters and boilers				
Subunit	Column	Externals	Internals	Control and monitoring	Miscellaneous
Maintainable items	Body/shell Packing Reflux coil/ condenser	Body/shell Piping Support Valves	Body/shell Burner Firetube Exhaust stack Tube coil Support	Actuating device Control unit Internal power supply Monitoring Sensors ^a Valves Wiring Piping Seals	Draft fan/motor Others
^a Specify type of sensor, e.g. pressure, temperature, level, etc.					

Table A.37 — Equipment-specific data — Heaters and boilers

Name	Description	Unit or code list	Priority
Energy source	Type of heating energy	Electricity, exhaust gas, fuel gas, hot oil, liquid fuel, steam	High
Heated/boiled medium	Type of fluid being heated/boiled	MEG, TEG, HC-based heating medium, water, water/TEG	High
Rated heat transfer	Design value	Kilowatt	High
Inlet temperature	Design value	Degrees Celsius	Medium
Outlet temperature	Design value	Degrees Celsius	Medium
Size – diameter	Specify	Millimetres	Medium
Size – length	Specify	Metres	Medium
Number of tubes	Specify	Number	Medium
Tube material	Specify	Specify	Low
Tube coil configuration	Specify	Helical, horizontal, single-pass, spiral, split-pass, vertical	Low
Packing type	—	Specify	High
Heater type	Direct-fired only	Box, cabin, cylindrical	Low
Number of burners	—	Number	Low

A.2.3.4 Pressure vessels

NOTE Pressure vessels include separators, scrubbers, cyclones, etc.

Table A.38 — Type classification — Pressure vessels

Equipment class — Level 6		Equipment type	
Description	Code	Description	Code
Pressure vessels	VE	Stripper	SP
		Separator	SE
		Coalescer	CA
		Flash drum	FD
		Scrubber	SB

Table A.38 (continued)

Equipment class — Level 6		Equipment type	
Description	Code	Description	Code
		Contactor	CO
		Surge drum	SD
		Cyclone	CY
		Hydrocyclone	HY
		Slug catcher	SC
		Adsorber	AD
		Dryer	DR
		Pig trap	PT
		Distillation column	DC
		Saturator	SA
		Reactor	RE
		De-aerator	DA

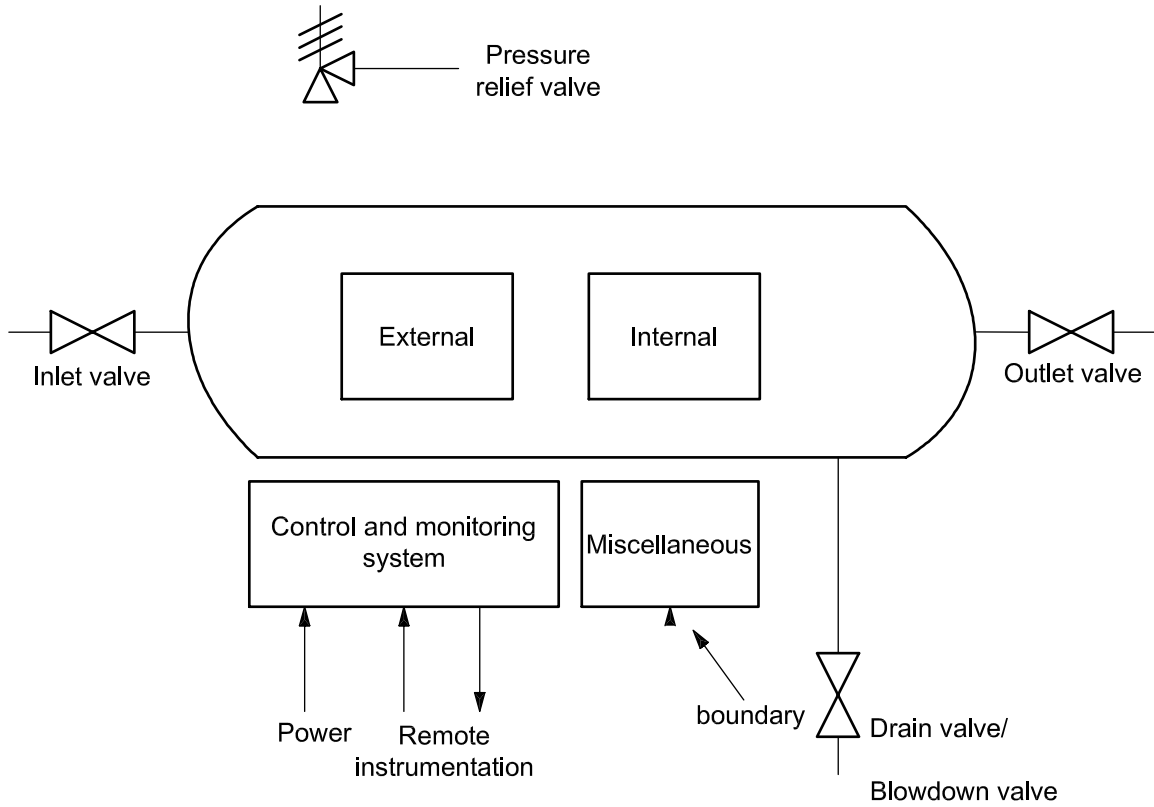

Figure A.13 — Boundary definition — Pressure vessels

Table A.39 — Equipment subdivision — Pressure vessels

Equipment unit	Pressure vessels			
Subunit	External items	Internal items	Control and monitoring	Miscellaneous
Maintainable items	Body/Shell Valves Piping Support	Body/Shell Cyclones ^b Hydrocyclone liners ^b Plates, trays, vanes, pads Nozzle Sand-trap system Heater Corrosion protection Distributor Coil	Actuating device Control unit Internal power supply Monitoring Sensors ^a Valves Wiring Piping Seals	Others
^a Specify type of sensor, e.g. pressure, temperature, level, etc. ^b Applies only for equipment type: Hydrocyclone.				

Table A.40 — Equipment-specific data — Pressure vessels

Name	Description	Unit or code list	Priority
Fluid(s)	Main fluid	Oil, gas, condensate, freshwater, steam, sea water, crude oil, oily water, flare gas, fuel gas, water/glycol, methanol, nitrogen, chemicals, hydrocarbon combined, gas/oil, gas/condensate, oil/water, gas/oil/water	High
Pressure – design	Design pressure	Pascal (bar)	High
Temperature – design	Design temperature	Degrees Celsius	Low
Pressure – operating	Operating pressure	Pascal (bar)	Medium
Temperature – operating	Operating temperature	Degrees Celsius	Low
Size – diameter	External	Millimetres	Medium
Size – length	External	Metres	Medium
Body material	Specify type or code	Free text	Low
Orientation	Specify	Horizontal, vertical, spherical	Low
Number of branches	Pressurized connections only	Number	Low
Internals	Design principle	Baffles, trays, grid plate, demister, heat coil, diverter, de-sander, combined	Low

A.2.3.5 Piping

Table A.41 — Type classification — Piping

Equipment class — Level 6		Equipment type	
Description	Code	Description	Code
Piping ^a	PI	Carbon steels	CA
		Stainless steels	ST
		High-strength low-alloy steels	LO
		Titanium	TI
		Polymers including fibre-reinforced	PO
^a May be used to represent ducts.			

The piping boundary definition will include all facilities to transfer and control fluid between pieces of rotating equipment, mechanical equipment and tanks, including also vent and drain lines to the environment. However, instrument tubing for pneumatic or hydraulic control is excluded.

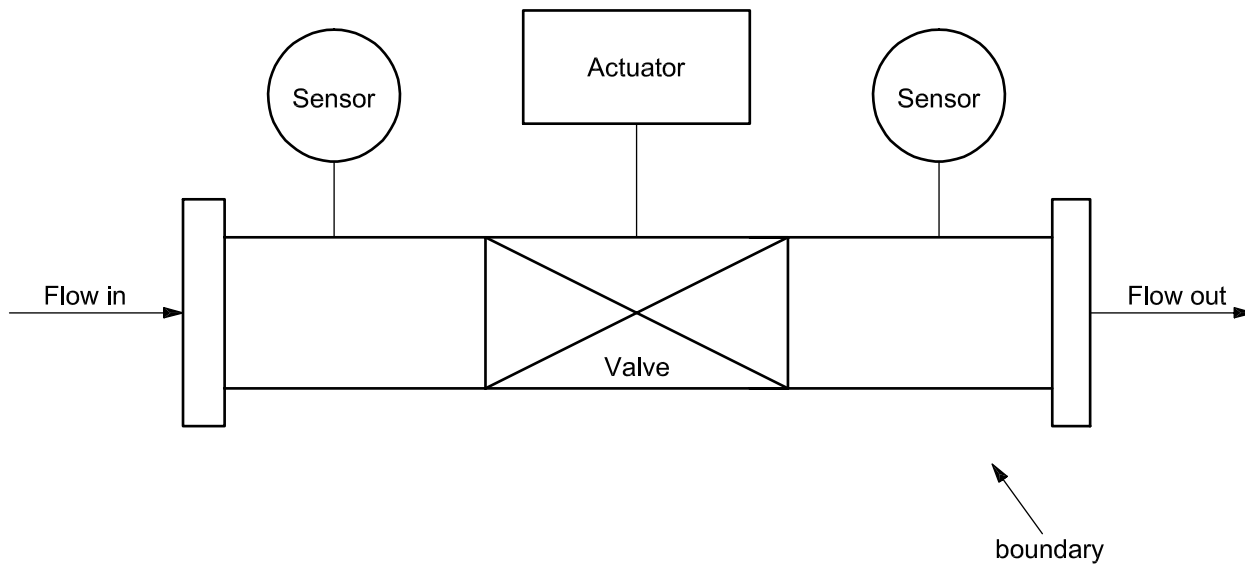

Figure A.14 — Boundary definition — Piping

Table A.42 — Equipment subdivision — Piping

Equipment unit	Piping			
Subunit	Pipe	Valve ^a	Control and monitoring	Miscellaneous
Maintainable items	Fastener/bolts Fitting Flange Header Lining Pipe element Plug Seals/gaskets	Valve body Valve seals Actuator Bonnet Accessories	Actuating device Control unit Internal power supply Monitoring Sensors ^b Valves Wiring Piping Seals	Pipe support Others
^a It should be marked if the valve(s) is/are registered as (a) separate equipment units(s) in the database (see also A.2.5.4). ^b Specify type of sensor, e.g. pressure, temperature, level, etc.				

Table A.43 — Equipment-specific data — Piping

Name	Description	Unit or code list	Priority
Diameter	Outer diameter	Millimetres	High
Wall thickness	Specify	Millimetres	Medium
Length	Total length	Metres	High
Design pressure	Max. allowable pressure	Pascal (bar)	High
Fluid handled	Type	Oil, gas, condensate, freshwater, steam, sea water, crude oil, oily water, flare gas, fuel gas, water/glycol, methanol, nitrogen, chemicals, hydrocarbon-combined, gas/oil, gas/condensate, oil/water, gas/oil/water	High
Fluid corrosive/erosive	Classify as shown in the footnote ^a	Benign, moderate, severe	Medium
Pipe material	Specify	Carbon steel, stainless steel, alloy type, composite, titanium etc.	Medium
Insulated	Specify	Yes/No	Low
Number of valves	Number of valves installed on the pipe length considered	Number	Medium
Type of valves	Specify valve category	PSV, ESD, HIPPS, manual, etc.	Low
Number of flanges	Specify	Number	Low
^a Benign (clean fluids, e.g. air, water, nitrogen). Moderately corrosive/erosive (oil/gas not defined as severe, sea water, occasionally particles). Severely corrosive/erosive [sour gas/oil (high H ₂ S), high CO ₂ , high sand content].			

A.2.3.6 Winches

Table A.44 — Type classification — Winches

Equipment class — Level 6		Equipment type	
Description	Code	Description	Code
Winches	WI	Electric winch	EW
		Hydraulic winch	HW

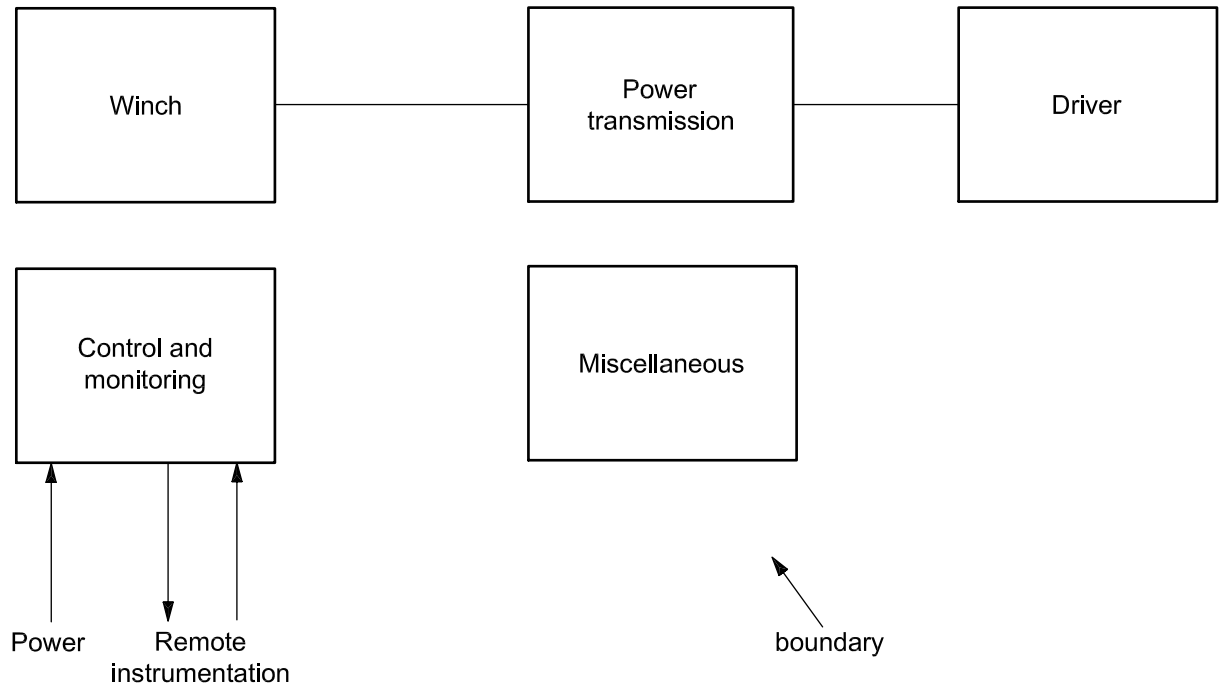

Figure A.15 — Boundary definition — Winches

Table A.45 — Equipment subdivision — Winches

Equipment unit	Winches			
Subunit	Winch	Power transmission	Control and monitoring	Miscellaneous
Maintainable items	Bearing Chain Drum Lubrication Reel Speedbrake Spool Structure Tensioning and motion compensation Wire	Bearing Coupling Gear Shaft	Actuating device Control unit Internal power supply Monitoring Sensors ^a Valves Wiring Piping Seals	Hood Others
^a Specify type of sensor, e.g. pressure, temperature, level, etc.				

Table A.46 — Equipment-specific data — Winches

Name	Description	Unit or code list	Priority
Type of driver	Equipment class, type and code	Specify	High
Wire/chain type	Type of hoisting line	Cable, chain, rope, umbilical, wire	High
Max. output	Max. input power – design	Kilowatt	High
Max. capacity	Max. load capacity	Metric tonnes	Medium
Drum capacity	Max. drum capacity	Metres	Low
Drum diameter	—	Metres	Low
Wire diameter	Wire/line thickness	Millimetres	Low
Speed – design	Max. operating speed	Revolutions per minute	High
Transmission type	Type	Direct, gear, integral	Low
Coupling	Type	Disconnect, fixed, flexible, hydraulic	Low
Lubrication of bearings	Type	Specify	Low
Radial bearing	Type	Antifrictional, journal, magnetic	Low
No. of drums	Number	Number	Low
Spooling device	As applicable	Yes/No	Low
Constant tensioning system	As applicable	Yes/No	Low
Heave compensation system	As applicable	Yes/No	Low
Regeneration of power	As applicable	Yes/No	Low
Remote control	As applicable	Yes/No	Low

A.2.3.7 Turrets

Table A.47 — Type classification — Turrets

Equipment class — Level 6		Equipment type	
Description	Code	Description	Code
Turrets	TU	Disconnectable turrets	DT
		Permanent turrets	PT

A.2.3.7.1 Boundary definitions for turrets

A.2.3.7.1.1 Disconnectable turrets

The disconnectable turret boundary is defined as follows:

- a) interfaces between the ship hull and the turret or buoy;
- b) mooring lines and anchors down to seabed included within boundary;
- c) interface between turret and turret compartment (boundary includes riser termination);
- d) manifold piping and valves between the riser termination and the swivel or dragged chain outside the boundary;
- e) control and monitoring equipment excluded from the boundary.

The boundary definition for permanent turrets is focused on the marine structures and dedicated turret systems.

A.2.3.7.1.2 Permanent turrets

The permanent turret boundary is defined as follows:

- a) The interface between the ship hull and the outer diameter of the turret defines the boundary between the ship structure and the turret.
- b) Mooring lines and anchors down to the seabed are included within the boundary.
- c) The interface between turret and turret compartment defines the upper boundary of the turret.
- d) The riser and umbilical termination is inside the equipment boundary.
- e) The risers are outside the boundary (covered as a separate equipment class).

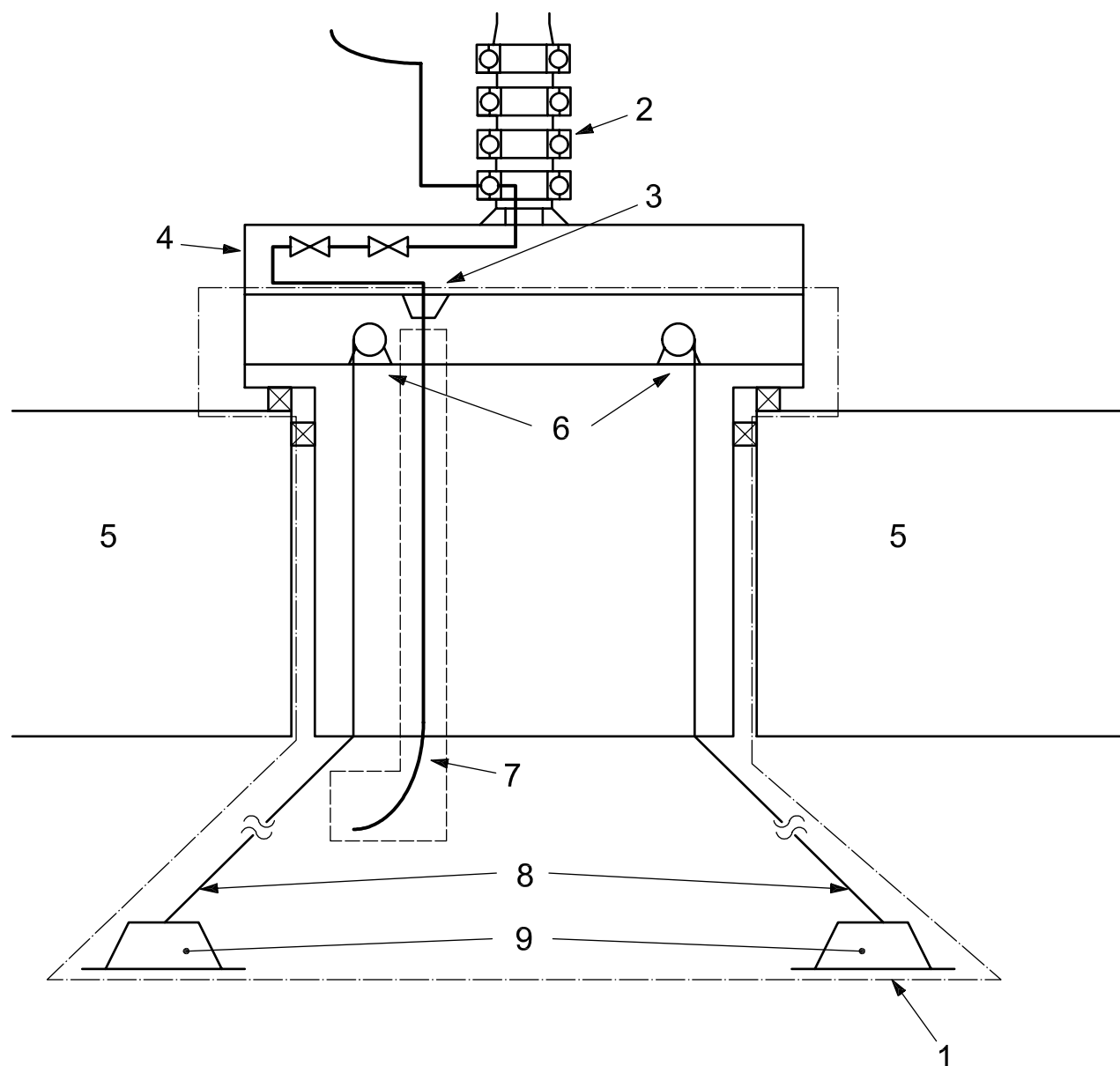

Key

- | | | | |
|---|---------------------|---|----------------|
| 1 | boundary | 6 | anchor winches |
| 2 | swivel | 7 | riser |
| 3 | riser termination | 8 | mooring lines |
| 4 | production manifold | 9 | anchors |
| 5 | ship | | |

Figure A.16 — Boundary definition — Turrets

Table A.48 — Equipment subdivision — Turrets

Equipment unit	Turrets			
Subunit	Turret	Mooring	Riser and umbilical termination	Utility systems
Maintainable items	Bearing-roller Bearing-slide Bearing-wheel Structure Turning and locking system	Anchor Buoy ^a Chain Synthetic rope Connection to structure Winch Wire	Bend-restrictor lock Hang-off	Ballast system Bilge system Lock buoy/ship system ^a Power system Pull-in ^a Ventilation
^a Only relevant for disconnectable turrets.				

Table A.49 — Equipment-specific data — Turrets

Name	Description	Unit or code list	Priority
Application	Main use	External loading, external production/injection, internal loading, internal production/injection	High
Turret location	Where installed on the vessel	Bow, stern, behind living quarter	High
Fluid transmission	Fluid-transfer method	Dragged chain, jumper, swivel	High
Rotation system	—	Active, passive	High
Riser termination	Type	Flanged, quick connect, quick disconnect, welded	High
Number of risers	—	Number	High
Number of umbilicals	—	Number	High
Number of anchor lines	—	Number	High
Wave height	Significant height – design value	Meters	Medium
Vessel displacement	—	Metric tonnes	Medium

A.2.3.8 Swivels

Table A.50 — Type classification — Swivels

Equipment class — Level 6		Equipment type	
Description	Code	Description	Code
Swivels	SW	Axial	AX
		Toroidal	TO
		Electric/signal	ES

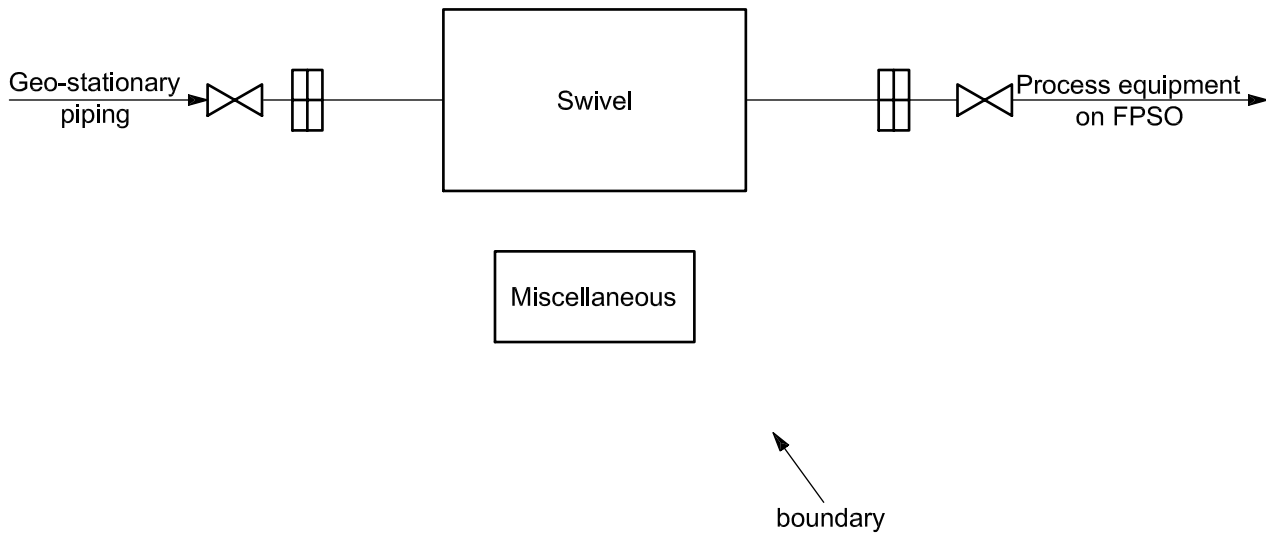

Figure A.17 — Boundary definition — Swivels

Table A.51 — Equipment subdivision — Swivels

Equipment unit	Swivels	
Subunit	Swivel	Miscellaneous
Maintainable items	Dynamic seals Bearing Liquid barrier system Bolting (incl. both structural and pressure connections) Casing Brushes ^a	Tensioners Common items
^a Only for electric swivels.		

Table A.52 — Equipment-specific data — Swivels

Name	Description	Unit or code list	Priority
Number of paths	For power and signal swivels no. of paths is defined as no. of services	Number	High
Design pressure	—	Pascal (bar)	Medium
Design temperature	—	Degrees Celsius	Low
Enclosure	Type of enclosure	Closed compartment, naturally ventilated	Medium
Produced-fluid corrosiveness	Type of service	Sweet service, sour service	Medium
Sand production	Measured or estimated sand production	Grams per cubic metre	Low
Electric power	Power swivels only	Kilowatt	Medium
Voltage – power	Power swivels only ^a	Volt	Medium
Voltage signal	Signal swivels only ^a	Volt	Medium
^a If several levels exist, record the most dominating and add further explanation as “Remarks”.			

A.2.3.9 Storage tanks

NOTE Storage tanks include atmospheric tanks and low-pressure tanks (non-refrigerated and refrigerated). This equipment class does not include offshore tanks (petroleum, diesel, MEG, drilling fluid, etc.) and underground storage cavern.

Table A.53 — - Type classification – Storage tanks

Equipment class - Level 6		Equipment type	
Description	Code	Description	Code
Storage tanks	TA	Fixed-Roof	FR
		Lifting Roof	LR
		Diaphragm	DP
		External Floating Roof	EF
		Roofless	RL
		Fixed Roof with Internal Floating Roof	IF

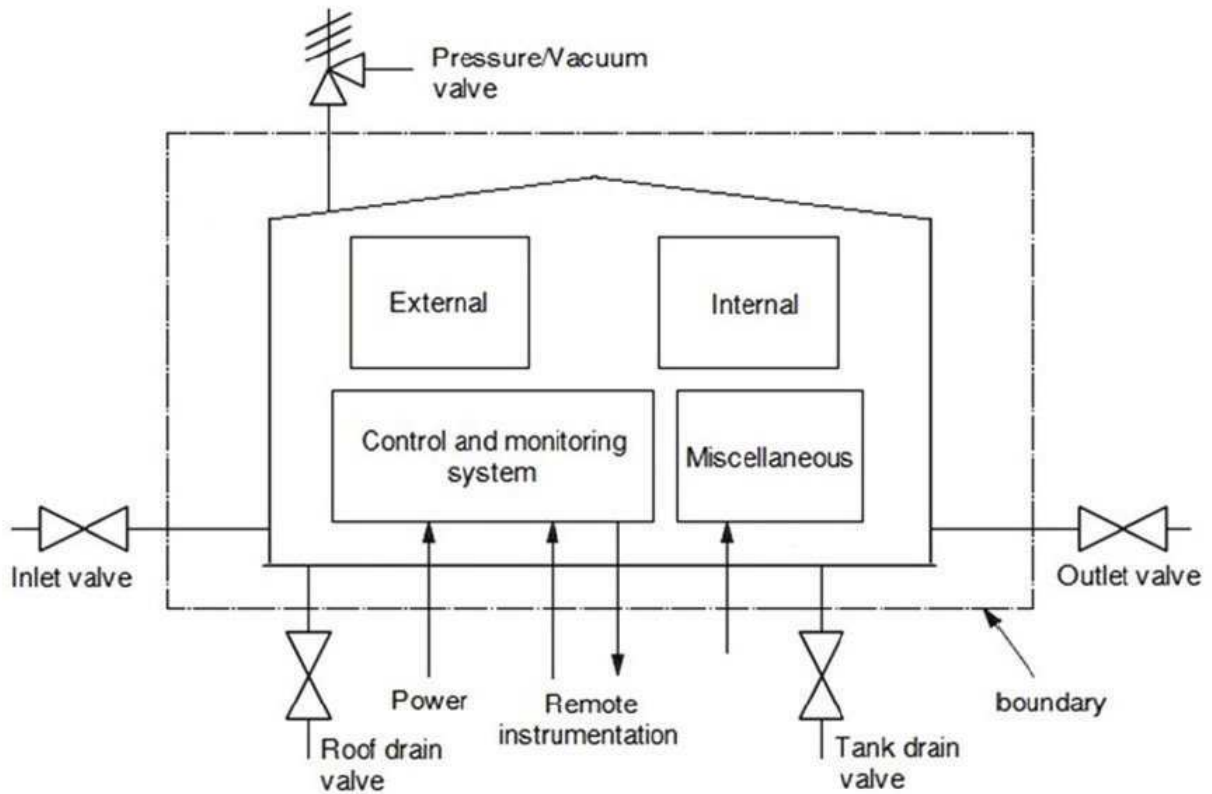

Figure A.18 — Boundary definition — Storage tanks

Table A.54 — Equipment subdivision — Storage tanks

Equipment unit	Storage tanks				
Subunit	Tank structure	External	Internal	Control and monitoring	Miscellaneous
Maintainable items	Shell (or side-walls) Roof Bottom Nozzles Manholes Cleanout Foundation	Bottom drain Roof drain ^c Seal ^c Platform Walkway Stairway Ladder ^c Centring and anti-rotation device ^c Secondary containment ^d	Heaters ^a Cathodic protection Nozzles Piping Swing line ^c	Sensors ^b Piping Open vent Flame arrester	Mixers Fire-fighting system Lightning protection system Others
^a Applicable for heated storage tanks only. ^b Specify type of sensor, e.g. pressure, temperature, level, etc. ^c Applicable for floating roof tanks only. ^d Applicable for refrigerated liquefied gas storage only.					

Table A.55 — Equipment-specific data — Storage tanks

Name	Description	Unit or code list	Priority
Stored product(s)	Main product(s)	Crude oil, oily water, gasoline, diesel, methanol, water, refrigerated LPG, refrigerated LNG, chemicals	High
Product specific gravity	Relative density	Number	Medium
Design standard	Design standard	Standard / edition / addendum	Medium
Design pressure	Maximum positive gauge pressure	Pascal (bar)	High
Design vacuum	Maximum partial vacuum	Pascal (bar)	High
Volume	Nominal liquid capacity	Cubic metres	Medium
Size – diameter	Nominal diameter	Metres	Medium
Size – height	Nominal height	Metres	Medium
Temperature - design	Maximum design temperature	Degrees Celsius	High
	Minimum design temperature	Degrees Celsius	High
Temperature - operating	Operating temperature	Degrees Celsius	Medium
Shell material	Specify type or code	Specify	Medium
Roof material	Specify type or code	Specify	Medium
Coating	Specify	Yes/No	Medium
Heating system	Specify	Yes/No	Low
Refrigerated tank system	Specify	Yes/No	Medium
Roof type	Fixed or floating	Fixed or floating	Medium
Floating roof type	Specify	Specify	Medium
Wall thickness	Nominal thickness (1 st course)	Millimetres	Medium
Mixer/agitator	Specify	Yes/No	Low
Secondary containment	Specify	Yes/No	Medium

A.2.4 Electrical equipment

A.2.4.1 Uninterruptible power supply (UPS)

Table A.56 — Type classification — UPS

Equipment class — Level 6		Equipment type	
Description	Code	Description	Code
UPS	UP	Dual UPS with standby bypass Rectifier supplied from emergency power Bypass from main power system	UB
		Dual UPS without bypass Rectifier supplied from emergency power	UD
		Single UPS with bypass Rectifier supplied from emergency power Bypass from main power system	US
		Single UPS without bypass Rectifier supplied from emergency power	UT

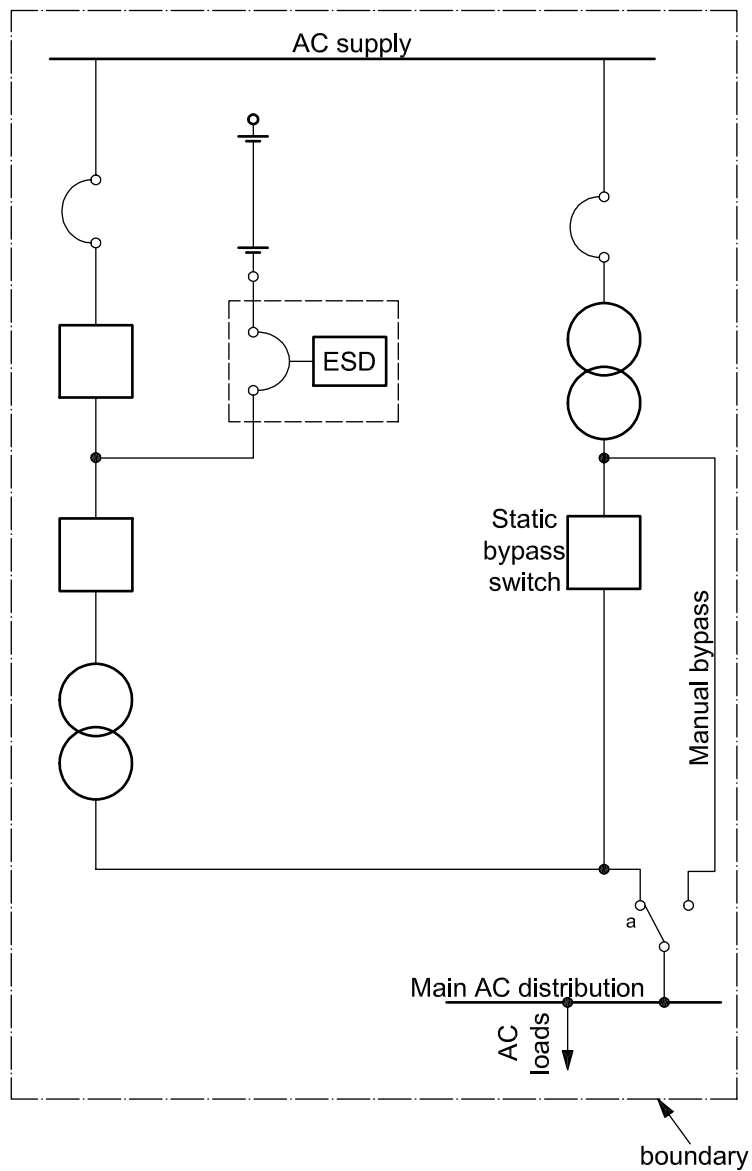

Key

^a Make-before-break switch.

Figure A.19 — Boundary definition — UPS

Table A.57 — Equipment subdivision — UPS

Equipment unit	UPS					
Subunit	Battery unit	Bypass unit	Inverter unit	Rectifier unit/ DC supply	Control and monitoring	Miscellaneous
Maintainable items	Battery breaker Battery bank Cabling Circuit breaker Connection/ socket Instrument	Bypass switch Bypass transformer Contactor feeder ^a Fuse(s) Instrument Static switch	Bypass switch Cabling Connection/ socket Fuse(s) Instrument Inverter Static switch Inverter transformer	Cabling Contactor feeder ^a Fuse(s) Fused switch Instrument Rectifier Rectifier transformer	Control unit Internal power supply Monitoring Sensors ^b Wiring Insulation monitoring device	Cabinet Insulation Cooling fans Others
^a Normally located in the supplying switchboard.						
^b Specify type of sensor, e.g. pressure, temperature, level, etc. See also equipment class Input devices in A.2.5.2, and in general, caution should be made with respect to which such items to include inside the equipment class UPS.						

Table A.58 — Equipment-specific data — UPS

Name	Description	Unit or code list	Priority
Application	What equipment the UPS is applied for	Circuit breaker, control systems, safety systems, telecommunication	High
System input voltage	Input voltage	Volt	High
Input frequency	Rated input	50 Hz or 60 Hz	High
Number of phases input voltage	1-phase or 3-phase	Number	High
Voltage variation	Input voltage	Percent	Low
Frequency variation	Input frequency	Percent	Low
System output voltage	Output voltage	Volt	High
Output frequency	Rated output	50 Hz, 60 Hz or DC	High
Number of phases output voltage	1-phase or 3-phase	Number	High
Rated output load and power factor	Apparent power and power factor in nominal operations	Kilovolt-amperes/cos ϕ	High
Degree of protection	Protection class in accordance with IEC 60529	IP code	Medium
Ambient temperature	Operating temperature range	Minimum and maximum temperature in degrees Celsius	Low
Cooling method	Specify	Water, air, others	Medium
UPS string system	The numbers of UPS systems which are working in parallel	Dual, single, triple	Medium
Rectifier/inverter bypass system	The type of bypass switch	Manual, static	Medium
Battery backup time	The time during which the battery can supply rated output power to the inverter	Minutes	Medium
Recharge time	The time to recharge the battery to 90 % capacity	Hours	Medium
Battery technology	Type of	NiCd, Pb-acid, other	Medium

Table A.58 (continued)

Name	Description	Unit or code list	Priority
Battery earth-fault monitoring	Specify	Common, individual, N.A.	Low
Method of ventilation	Specify	Forced, natural	Low
Number of battery banks	Specify	Number	Medium

A.2.4.2 Power transformers

NOTE The power transformers covered in this A.2.4.2 are used in conjunction with offshore (topsides) and onshore power supply for e.g. electric motor. Subsea power transformers are covered in A.2.6.5 as maintainable item. Some information in A.2.4.2 can be relevant if such items are to be subject to more detailed reliability data collection.

Table A.59 — Type classification — Power transformers

Equipment class — Level 6		Equipment type	
Description	Code	Description	Code
Power transformers	PT	Oil immersed	OT
		Dry	DT

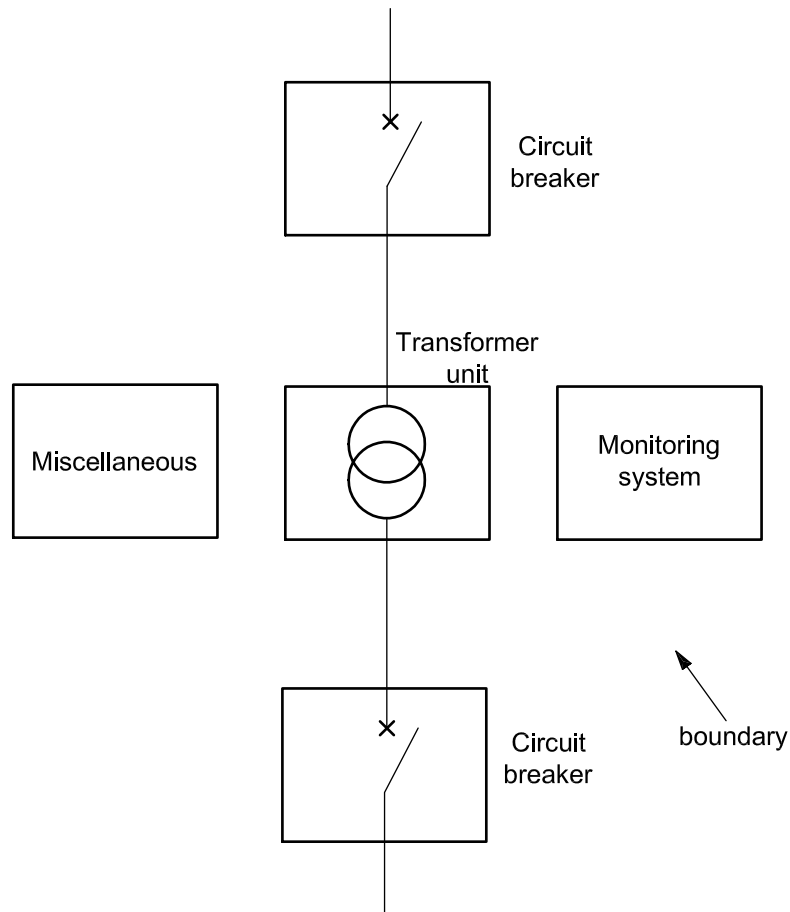

Figure A.20 — Boundary definition — Power transformers

Table A.60 — Equipment Subdivision — Power transformers

Equipment unit	Power transformers ^a		
Subunit	Transformer unit	Monitoring system	Miscellaneous
Maintainable items	Oil Tank Windings Fan Core Expansion tank Radiator Tap changer Neutral impedance Outer tank ^b	Bucholz relay Level indicator Thermometer Relief valve Pressure relay Current transformers	Bushing insulators Terminal blocks Connectors Wiring Grounding Junction box Silica-gel device Dampers Penetrator ^b Neutral grounding resistors (NGRs)
<p>^a For non-subsea equipment classes, note variations between frequency converters, power transformers, and VSD electric motors.</p> <p>^b Subsea application</p> <p>^c Note a subsea power transformer located on the seabed as part of Equipment class “Subsea electrical power distribution” (see A.2.6.5) is a maintainable item. As part of “Subsea electrical power distribution”, there could step-up and/or step-down transformers that are located topsides/onshore, and these would be same as the equipment class Power transformer in Table A.60.</p>			

Table A.61 — Equipment-specific data — Power transformers

Name	Description	Unit or Code list	Priority
Frequency	Rated frequency	Hertz	Low
Primary voltage	Rated voltage	Kilovolts	High
Secondary voltage	Rated voltage	Kilovolts	High
Voltage additional windings	Rated voltage tertiary or further windings	Kilovolts	High
Power – design	Rated power	Kilovolt-amperes	High
Power factor	$\cos \varphi$	Number	Low
Efficiency	Efficiency factor (η)	Number = 1	Medium
Degree of protection	Protection class in accordance with IEC 60529	Code as in IEC 60529:2001, Clause 4	Low
Thermal class designation	Thermal class in accordance with IEC 60085	Y, A, E, B, F, H, 200, 220, 250	Medium
Temperature rise	In accordance with IEC 60076-2	Degrees Celsius	Low
Transformer cooling	Type in accordance with IEC 60076-2	Code as in IEC 60076-2:1993, Clause 3	High
Number of phases	1-phase or 3-phase	Number	High
Level of insulation	Insulation in accordance with IEC 60076-3	Kilovolts	High
Three-phase transformer connection	Type and combination of connections (vector groups) as star, delta, etc. in accordance with IEC 60076-1	Code as recommended in IEC 60076-1:2000, Annex D	High
Type of dry transformer winding	Specify if the windings are encapsulated in solid insulation. Cast resin is an example of solid insulation.	Encapsulated/not encapsulated	Medium

A.2.4.3 Switchgear

Switchgear have a wide application offshore and onshore for the distribution and protection of high and low voltage power systems. The classification includes both high voltage (>1KV) and low voltage (<1KV) applications. High voltage boards can be air insulated or gas insulated, as shown in [Table A.62](#). It should be noted that low voltage switchgear also includes distribution boards.

Single phase, three phase and direct current applications are included in the scope.

Table A.62 — Type classification — Switchgear

Equipment class - Level 6		Equipment type	
Description	Code	Description	Code
Switchgear	SG	Low voltage	LV
		Oil and vacuum insulated	OV
		High voltage air insulated	HA
		High voltage gas insulated	HG

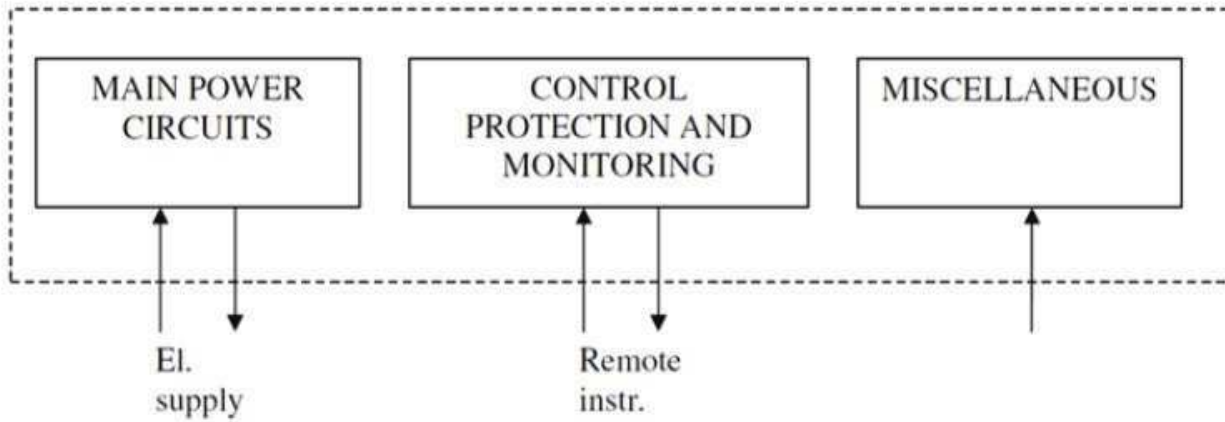

Figure A.21 — Boundary definition — Switchgear

Table A.63 — Equipment Subdivision — Switchgear

Equipment unit	Switchgear		
Subunit	Main power circuits	Control protection and monitoring	Miscellaneous
Maintainable items	Circuit breaker ^a Cable termination Current transformers Voltage transformers Disconnectors Earthing switch Motor starters (contactor) Actuator ^d Busbar ^g	Metering ^b Protection relay and interlock ^c Control power supply Miniature circuit breakers (MCB) Communication interface Terminal blocks and connectors PLC Sensor ^e Valve Piping Wiring	Interface cabinet Cooling Enclosure ^f (cabinet)
<p>^a Includes internals, such as closing coil, trip coil, position sensor, spring etc.</p> <p>^b Includes voltmeters and ammeters.</p> <p>^c The interlock may either be included as software in the protection relay, or as conventional relay logic.</p> <p>^d Actuator for energising the mechanism for release of the circuit breaker.</p> <p>^e For gas insulated switchgear (equipment type HG), sensor will be provided for monitoring the over-pressurized chamber.</p> <p>^f The racking mechanism is part of Enclosure. The cables into and out of the enclosure is not considered as part of the scope.</p> <p>^g Busbar insulators are a part of the busbar.</p>			

Table A.64 — Equipment-specific data — Switchgear

Name	Description	Unit or code list	Priority
System application	Description of the switchboard application (services supplied)	Control system, safety system	Medium
Rated system voltage	Expected operation voltage	Volts, AC or DC	High
Rated busbar current	Maximum continuously current at specified conditions	Amperes	High
Rated short time withstand current	The rms value of the short circuit current which the switchgear shall withstand during the specified time	Kilo Amperes (kA)	Low
Rated duration of short circuit	The interval of time in which the switchgear shall withstand specified short time withstand current	Seconds	Low
Utilization of capacity	Normal operating/design capacity	%	High
Rated frequency	Normal operation frequency	Hertz	High
Number of circuits	Number of outgoing connections	Number	Medium
Degree of protection	Environmental protection for the cabinet	IP rating	Low
Hazardous area rating	EEX hazardous area rating according to IEC 60079	Specify	Medium
Switches/Breaker rating	Switches/Breaker rating (A)	Specify	Low

A.2.4.4 Frequency converters

A Variable Speed Drive Systems (VSDDS), or Adjustable Speed Drive Systems (ASDDS), is intended to provide power to electric motor(s) such that the speed or torque of the motor(s) may be varied. Frequency Converters, also known as Variable Frequency Drive System (VFDS), are applicable for AC electric motors. The VSDDS can consist of a frequency converter if it is an AC type VSDDS.

VSDDS have considerable application in the oil and gas industry ranging from the simple speed control of a HVAC system to the speed control of a subsea pump in a subsea processing system.

Note that the equipment class “Frequency converters” is thus related to the equipment classes “Electric motor” (A.2.2.4), “Power transformers” (ref. A.2.4.2), “Subsea electrical power distribution” (A.2.6.5) and “Electrical submersible pumps” (A.2.7.6) described elsewhere in this International Standard. For example, a VSD driven electric motor driving a compressor will need to include different equipment classes when reliability data collection or estimation is done. Note that a subsea frequency converter however, is a maintainable item for the equipment class “Subsea electrical power distribution” (ref. A.2.6.5).

Table A.65 — Type classification — Frequency converters

Equipment Class - Level 6		Equipment type	
Description	Code	Description	Code
Frequency converters	FC	Low voltage	LV
		High voltage	HV

The figure below shows a typical configuration for a Variable Speed Drive System. The equipment class Frequency converters is given in [Figure A.22](#). [Figure A.22](#) is shown to illustrate how the Frequency converters fit in the VSDDS and the dependencies on other components, like equipment classes Power transformers (see A.2.4.2) and Electric motors (see A.2.2.4).

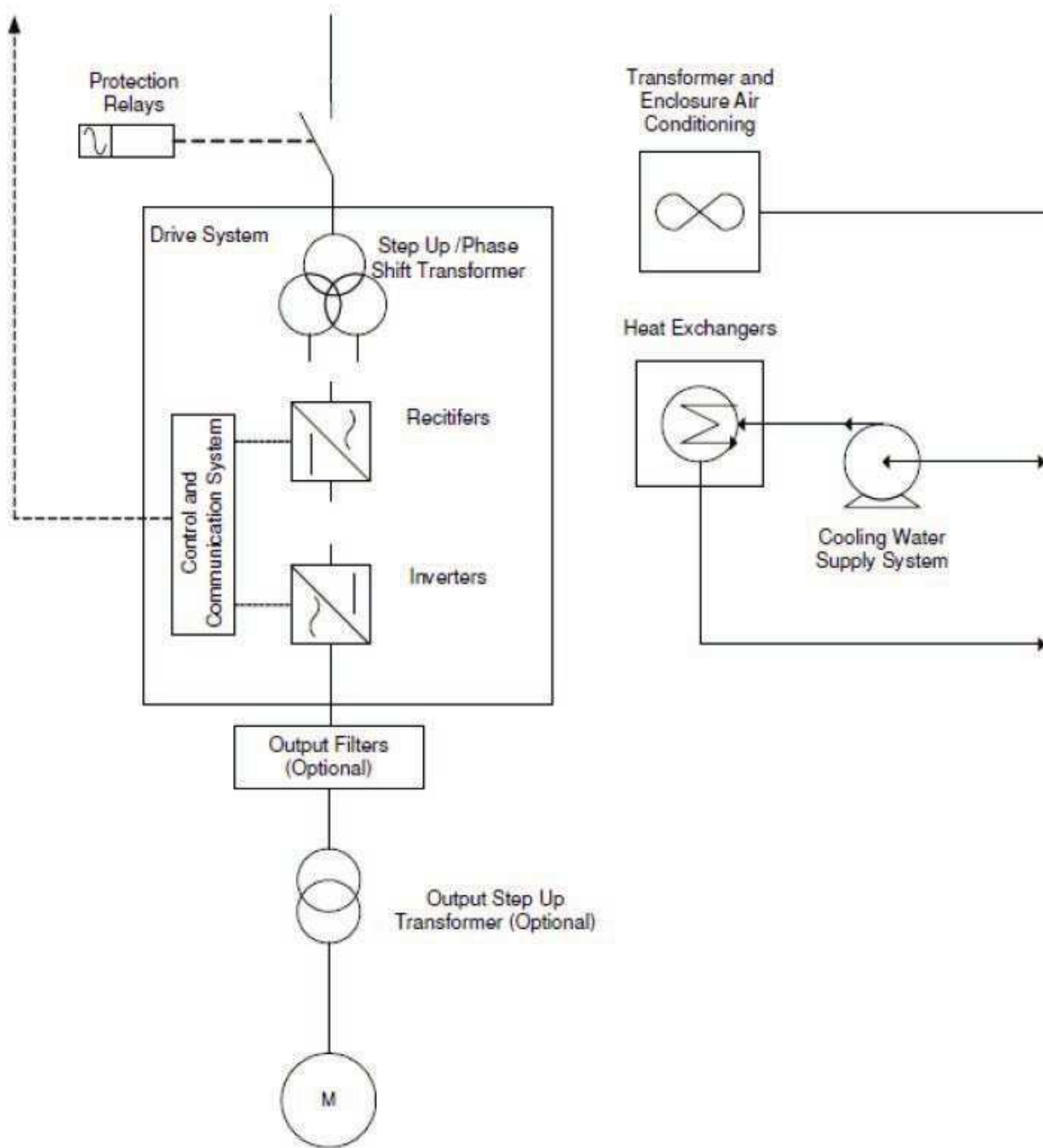

Figure A.22 — Typical VSDS configuration with frequency converters

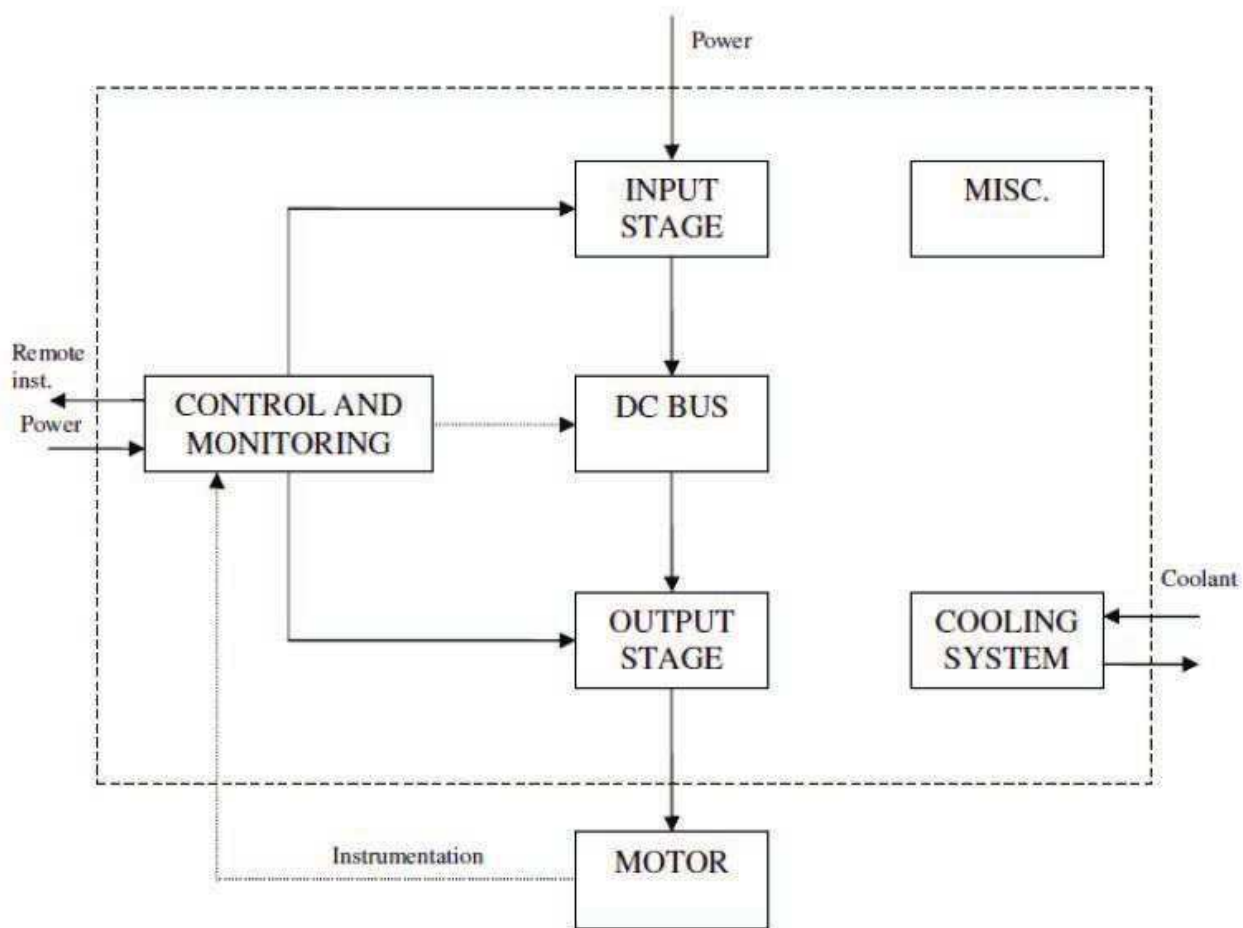

Figure A.23 — Boundary definition — Frequency converters

Table A.66 — Equipment Subdivision — Frequency converters

Equipment unit	Frequency converters					
Subunit	Input stage	DC bus	Output stage	Control and monitoring	Cooling system	Miscellaneous
Maintainable items	Rectifiers	Capacitors	Inverter	Monitoring ^a	Heat exchanger	Heaters
	Protective devices	Inductors	Output filters	Control unit	Filter	Enclosure fixtures and fittings
	Internal circuit breaker or disconnect	Charging circuits	Power cell	Internal power Supply	Motor	Excitation circuits
	Harmonic filter	Brake choppers		Communication	Piping	
	Commutating reactor	Internal circuit breaker or disconnect		Cards	Pump	
	Input transformer ^c	Switch fuses		Instruments	Seals	Bypass contactor
		Fuses		Wiring	Valves	
			Miniature circuit breakers/fuses	Enclosure cooling fans		
			Isolation switch	De-ioniser ^b		
				Louver		

^a Specify type of instrument/sensor, current, voltage, power, speed, contactor feedback.

^b For some high voltage units (Equipment type = HV) there will be de-ionised closed water loop for cooling, which would consist of piping and motor, but also a de-ioniser unit.

^c The input transformer is inside the frequency converter (in a VSFS configuration) and is different from a normal power transformer, but may still also use equipment class "Power transformer" (see [Table A.60](#)) if further sub-division is needed.

Table A.67 — Equipment-specific data — Frequency converters

Name	Description	Unit or code list	Priority
Corresponding driven unit	Equipment unit (electric motor) which the Frequency Converter is connected to	Tag	Medium
System identification	System identification number	Number	High
Voltage type	Design characteristic	AC, DC	High
Type of commutation	Describe as per code list	Self-commutated, line/load commutated	Low
Application	Where applied	Compressor application, subsea, downhole, process, drilling, utility	High
Supply voltage	Supply voltage	Volts	Low
Power - design	Design/rated power of the system	Kilowatts (kW), Megawatts (MW), MegaVoltAmpere (MVA)	High
Utilization of capacity	Normal operating/design capacity	%	Medium
Operating frequency range	Normal range of output frequency	Hertz	Low
Converter type	Describes whether the rectifier provides power back into the supply system	One, two or four quadrant	Medium
Incoming transformer connections	Describes the input connection, whether a transformer is used and its design intent	Step up, step down, isolating, phase shifting	Medium
Output conditioning	Describes the output connection, whether output conditioning is used or a step up transformer	Output filters, step up transformers	Medium

Table A.67 (continued)

Name	Description	Unit or code list	Priority
Cooling system design	What cooling mechanisms are used for the VSDS, transformers, braking resistors and enclosures	Liquid cooling, air forced cooling. (Indicate most dominant since there in practice often is a combination of the two)	High
Hazardous area rating	EEX Hazardous area rating in according with IEC 60079	Specify	High
Ingress protection rating	Ingress protection rating in according with IEC 60529	Specify	Medium

A.2.5 Safety and control

A.2.5.1 Fire and gas detectors

Table A.68 — Type classification — Fire and gas detectors

Equipment class — Level 6		Equipment type	
Description	Code	Description	Code
Fire and gas detectors	FG	Fire detection (FGA)	
		Smoke/Combustion	BS
		Heat	BH
		Flame	BF
		Manual pushbutton	BM
		Others	BA
		Gas detection (FGB)	
		Hydrocarbon	AB
		Toxic gases	AS
		Others	AO

NOTE: Failure mode code FG is split into FGA and FGB. See also [Table B.9](#).

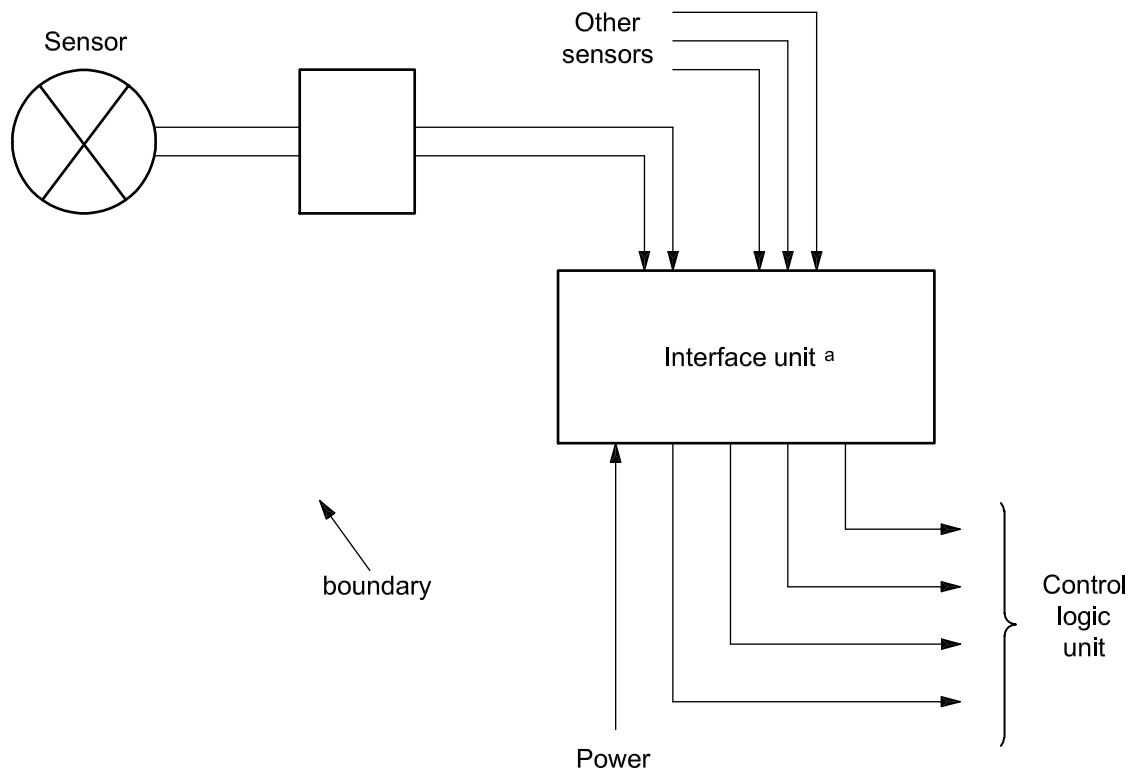

Key

^a Not applicable for all fire and gas sensors.

Figure A.24 — Boundary definition — Fire and gas detectors

A.2.5.1.1 Boundary definitions for fire and gas detectors

Field input devices such as fire and gas detectors are usually connected to a fire and gas control logic unit (CLU), which is not included in the boundary of fire and gas detectors (see Figure A.19). Monitoring/interface units may be used between detector and CLU, and this is part of the fire and gas detectors. The purpose of these units is, among others, to monitor the detectors, their interface connections and cables, analysing the incoming data by different algorithms and initiating fault or alarm signals. The basic principle of data communication between field equipment and such interface systems can be based on multiplexing and sequential polling of data.

Table A.69 — Equipment subdivision — Fire and gas detectors

Equipment unit	Fire and gas detectors			
	Subunit	Sensor	Interface unit ^a	Miscellaneous
Maintainable items	Cabling	Cabinet	Others	
	Cover	Control card		
	Detector (incl. head and associated electronics)	Display		
	Mounting socket			
^a Not applicable for all fire and gas sensors.				

Table A.70 — Equipment-specific data — Fire and gas detectors

Name	Description	Unit or code list	Priority
Functional characteristics			
Location on installation	Where installed	Drill floor, wellhead, process, auxiliary, mud processing, power generation, utility, control room, auxiliary room, living quarter	High
Environment	Exposure	Severe, moderate, low, unknown ^a	High
Item characteristics			
Sensing principle	Type	Fire: Ionization, optical, IR, UV, IR/UV, rate rise, rate comp., fixed temp., fusible plug, camera, multisensor (optical/heat) Gas: Catalytic, electrochemical, photoelectrochemical, photoelectric beam, IR, UV, acoustic, camera, aspirating, optical beam, solid state	High
Detector communication	Type	Conventional, addressable (one-way), smart (two-way)	Medium
Fault tolerance ^b	Response at failure	Yes/No	Medium
Self-test feature	Degree of self-testing	No self-test, automatic loop test, built-in test, combined	Medium
Type of Ex protection	Explosion classification category, e.g. Ex(d), Ex(e) ^c	Ex(d), Ex(e), Ex(i), none	Low
^a Environment classification: Severe not enclosed and/or outdoor; heavily exposed (vibration, heat, dust, salt); Moderate partly enclosed and/or moderately exposed (vibration, heat, dust, salt); naturally ventilated; Low enclosed and/or indoor; minor exposure (vibration, heat, dust, salt); mechanically ventilated. ^b Design based on de-energized principle is compatible with fail-safe philosophy. A safety-instrumented system operating in "normally energized" mode can be designed to fail-safe on loss of power or signal. ^c See IEC 60079 (all parts).			

A.2.5.2 Input devices

Input devices are, in general, sensors that convert process parameters into an electrical signal that can be monitored. Typical main categories of input devices are the following:

- transmitter: converts process parameter, e.g. pressure, into proportional electrical signals, typically 4 mA to 20 mA or 0 V to 10 V (see IEC 60381-2);
- transducer: converts process parameters, e.g. pressure, into proportional electrical signals, typically unamplified output;
- switch: converts process parameters, e.g. pressure, typically into on/off electrical signals.

Table A.71 — Type classification — Input devices

Equipment class — Level 6		Equipment type	
Description	Code	Description	Code
Input devices	IP	Pressure	PS
		Level	LS
		Temperature	TS
		Flow	FS

Table A.71 (continued)

Equipment class — Level 6		Equipment type	
Description	Code	Description	Code
		Speed	SP
		Vibration	VI
		Displacement	DI
		Analyser	AN
		Weight	WE
		Corrosion	CO
		Limit switch	LP
		On/off (pushbutton)	PB
		Others	OT

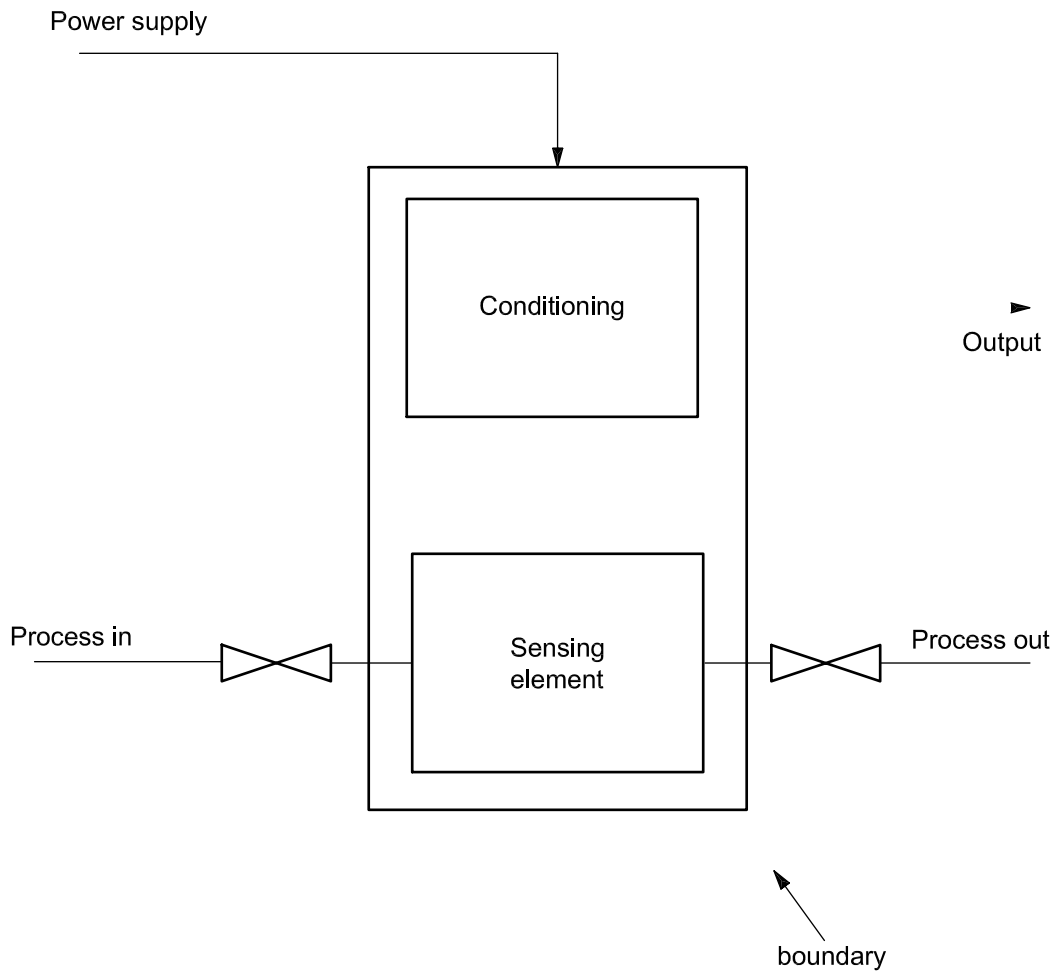

NOTE This boundary drawing does not apply for switches and pushbuttons.

Figure A.25 — Boundary definition — Input devices

Table A.72 — Equipment subdivision — Input devices

Equipment unit	Input devices	
Subunit	Sensor and electronics	Miscellaneous
Maintainable items	Sensing element Conditioning (electronics)	Cabling Piping Others

Table A.73 — Equipment-specific data — Input devices

Name	Description	Unit or code list	Priority
Functional characteristics			
Location on installation	Where installed	Drill floor, wellhead, process, auxiliary, mud processing, power generation, utility, control room, auxiliary room, living quarter	High
Application	Where applied	Process control, emergency shutdown, process shutdown, pressure reduction, bypass, blowdown, monitoring, combined	High
Fluid/gas corrosiveness/erosiveness	Classify as explained in footnote ^a	Benign, moderate, severe	Medium
Item characteristics			
Category	Main category	Transmitter, transducer, switch, pushbutton	High
Sensing principle	Applicable for pressure sensors only	Bonded strain, semiconductor, strain, piezoelectric, electromechanical, capacitance, reluctance, oscillating wire	High
	Applicable for level sensors only	Differential-pressure cell, capacitance, conductive, displacement, diaphragm, sonic, optical, microwave, radio frequency, nuclear	High
	Applicable for temperature sensors only	Resistance temperature detector (PT), thermocouple, capillary	High
	Applicable for flow sensors only	Displacement, differential head (closed conduit/pipe, open channel), velocity, mass	High
	Insert additional types as relevant (e.g. speed, vibration)	To be defined by user as required	High
Sensor voting, <i>k</i> out of <i>Y</i> (only as relevant)	At least <i>k</i> out of the total number, <i>Y</i> , of sensors shall provide signal to initiate control/safety action. <i>k</i> and <i>Y</i> shall be entered; if no voting, leave blank.	<i>k</i> = “xx” (integer) <i>Y</i> = “yy” (integer)	Low
Fault tolerance	Response at failure	Yes/No	High
Detector communication	Type	Conventional, addressable (one-way), smart (two-way)	Medium
Self-test feature	Degree of self-testing	No self-test, automatic loop test, built-in test, combined	High
Type of protection	Explosion classification category, e.g. Ex(d), Ex(e) ^b	Ex(d), Ex(e), Ex(i), None	Low
^a Benign (clean fluids, e.g. air, water, nitrogen). Moderately corrosive/erosive (oil/gas not defined as severe, sea water, occasionally particles). Severely corrosive/erosive [sour gas/oil (high H ₂ S), high CO ₂ content, high sand content].			
^b See IEC 60079 (all parts).			

A.2.5.3 Control logic units

Table A.74 — Type classification — Control logic units

Equipment class — Level 6		Equipment type	
Description	Code	Description	Code
Control logic units	CL	Programmable logic controller (PLC)	LC
		Computer	PC
		Distributed control unit	DC
		Relay	RL
		Solid state	SS
		Single-loop controller	SL
		Programmable automation controller (PAC)	PA

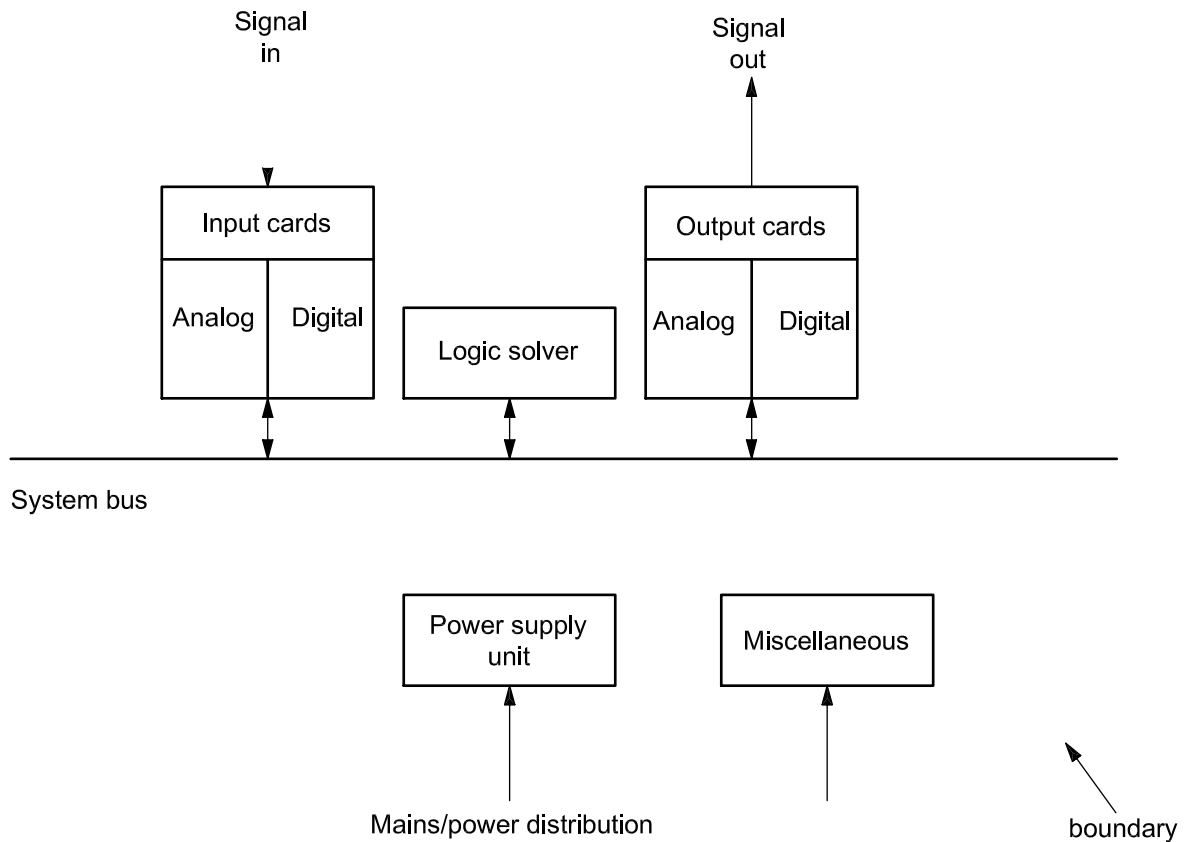

Figure A.26 — Boundary definition — Control logic units

Table A.75 — Equipment subdivision — Control logic units

Equipment unit	Control logic units							
Subunit	Analog input cards	Digital input cards	Analog output cards	Digital output cards	Logic solver	System bus	Power supply	Miscellaneous
Maintainable items	Input card Connection unit	Input card Connection unit (X-wiring)	Output card Connection unit (X-wiring) Relay	Output card Connection unit (X-wiring) Relay	Central processor unit (CPU) Random access memory (RAM) Watchdog/diagnostic Software	No subdivision	No subdivision	Galvanic barriers Others

Table A.76 — Equipment-specific data — Control logic units

Name	Description	Unit or code list	Priority
Application - control logic	Where used	Centralized, distributed, man-machine interface	Medium
CLU redundancy configuration	Specify if there are redundant Control logic units (CLUs) installed	Yes/No	Low
Self-test feature	Degree of self-testing	No self-test, automatic-loop test, built-in test, combined	High
Fault tolerance	Response at failure	Yes/No	High

A.2.5.4 Valves

NOTE The valves described in the taxonomy classification given in [Table A.77](#) do not apply for valves used for specific upstream purposes like subsea valves and valves used in downhole completion. These valves are covered in the specific sub-clauses in [Annex A](#) on this type of equipment. Wellhead and X-mas trees (dry) are, however, considered as topside valves.

Table A.77 — Type classification — Valves

Equipment class — Level 6		Equipment type	
Description	Code	Description	Code
Valves	VA	Ball	BA
		Gate	GA
		Globe	GL
		Butterfly	BP
		Plug	PG
		Needle	NE
		Check	CH
		Diaphragm	DI
<p>NOTE 1 Pilot valves are normally non-tagged components used for self-regulation. PSV solenoid valves are normally a sub-tag of a valve tag used for all ESD/PSD. Quick-exhaust dump valves are specific valves used if quick response is required (e.g. HIPPS function). Relief valves are normally PSV valves.</p> <p>NOTE 2 Valves of a specific type not defined in this table should be coded as OH (Others) with a comment specifying type description. Example: Clack- or Elastomer-type Deluge valves).</p>			

Table A.77 (continued)

Equipment class — Level 6		Equipment type	
Description	Code	Description	Code
		Flapper	FL
		Multiple orifice	MO
		Three-way	WA
		PSV-conventional	SC
		PSV-conventional with bellow	SB
		PSV-pilot operated	SP
		PSV-vacuum relief	SV
		Plug and cage	PC
		External sleeve	ES
		Disc	DC
		Axial flow	AF
		Pinch	PI
		Others	OH
<p>NOTE 1 Pilot valves are normally non-tagged components used for self-regulation. PSV solenoid valves are normally a sub-tag of a valve tag used for all ESD/PSD. Quick-exhaust dump valves are specific valves used if quick response is required (e.g. HIPPS function). Relief valves are normally PSV valves.</p> <p>NOTE 2 Valves of a specific type not defined in this table should be coded as OH (Others) with a comment specifying type description. Example: Clack- or Elastomer-type Deluge valves).</p>			

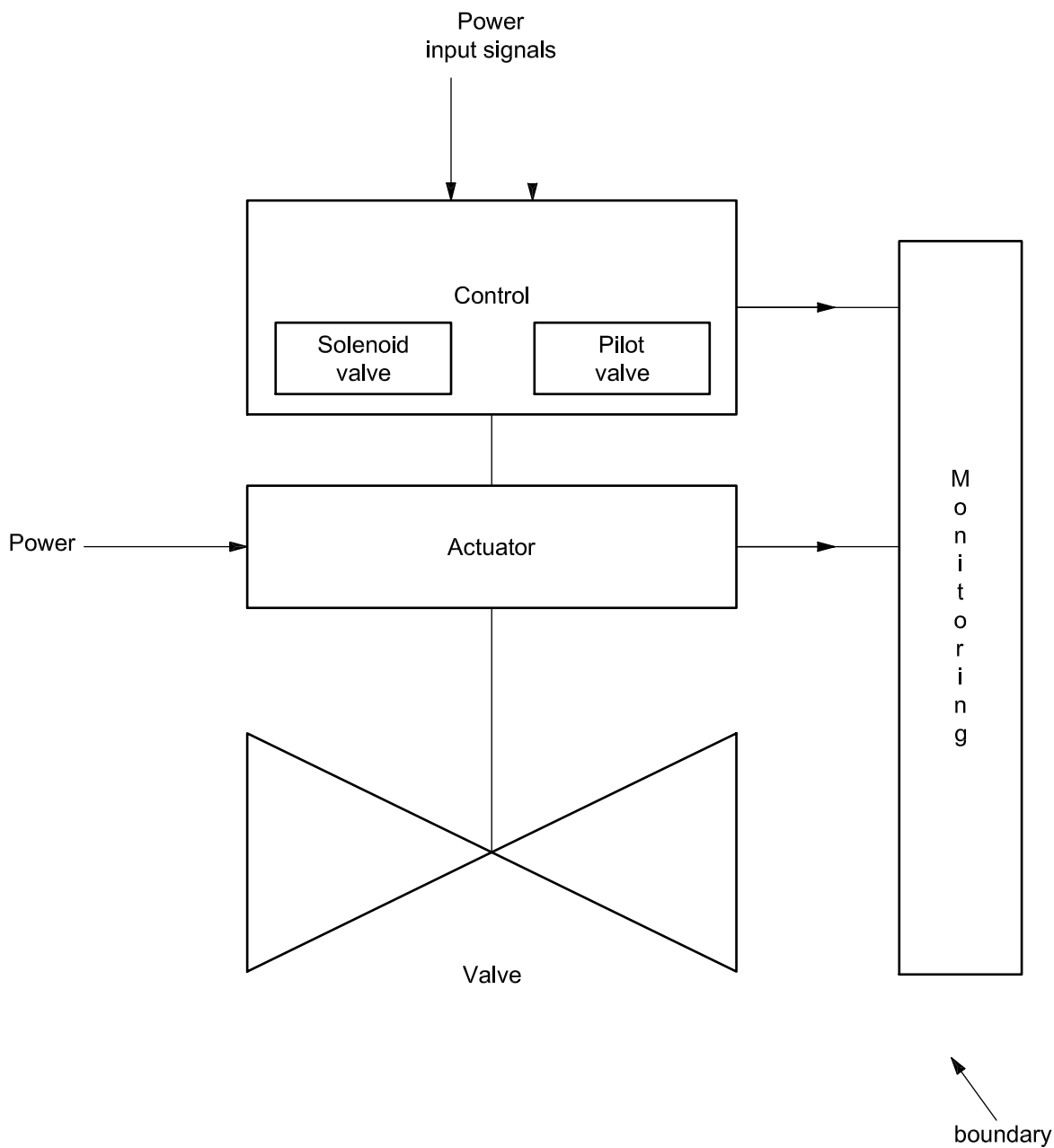

Figure A.27 — Boundary definition — Valves

Table A.78 — Equipment subdivision — Valves

Equipment unit	Valves			
Subunit	Valves	Actuator ^a	Control and monitoring ^a	Miscellaneous
Maintainable items	Valve body	Diaphragm	Wiring	Accumulator
	Bonnet	Spring	Indicator	Others
	Flange joints	Case	Instrument, general	
	Seat rings	Piston	Instrument, position	
	Packing/stem seal	Stem	Monitoring	
	Seals	Seals/gaskets	Solenoid valve	
	Closure member	Electrical motor ^b	Pilot valve ^c	
	Stem	Gear	Quick exhaust dump valve	
	Travel stop	Internal power supply		
		Limit switch		
^a	Not applicable for all valve categories.			
^b	Electric-motor actuator only.			
^c	Applicable for hydraulic/pneumatically actuated valves.			

Table A.79 — Equipment-specific data — Valves

Name	Description	Unit or code list	Priority
Main function	Main functional category	Flow control, on/off, non-return, Pressure relief, instrument or hydraulic control	High
Application	Specify function in the process	Annulus (X-mas tree), blowdown, bypass, injection, X-over, Deluge, ESD, ESD/PSD, PSD, HIPPS, swab, wing, relief, control, choke	High
Where mounted	Equipment on which the valve is installed	Wellhead, X-mas tree, wellhead flow line, wellhead injection line, pump, turbine, generator, separator, heat exchanger, vessel, header, electric motor, diesel motor, turboexpander, drilling, pipeline, mud process, utility, living quarter, air inlet, riser	High
Size	Internal diameter	Millimetres (inches)	Medium
Fluid handled	Main fluid only	Oil, gas, condensate, freshwater, steam, sea water, crude oil, oily water, flare gas, fuel gas, water/glycol, methanol, nitrogen, chemicals, hydrocarbon combined, gas/oil, gas/condensate, oil/water, gas/oil/water, NGL, LPG, LNG, slurry, etc.	High
Fluid temperature	Operating temperature main fluid	Degrees Celsius	Medium
Fluid corrosiveness/erosiveness	Classify as shown in the footnote ^a	Benign, moderate, severe	Medium
Flowing pressure	Normal operating pressure (inlet)	Pascal (bar)	Medium
^a	Benign (clean fluids, e.g. air, water, nitrogen). Moderately corrosive/erosive (oil/gas not defined as severe, sea water, occasionally particles). Severe corrosive/erosive [sour gas/oil (high H ₂ S), high CO ₂ content, high sand content].		
^b	Primary actuation principle:		
1	single-acting = actuation force by gas (air) or hydraulic fluid for either opening or closing the valve;		
2	double-acting = actuation force by gas (air) or hydraulic fluid for both opening and closing the valve;		
3	actuation by line/process pressure or actuation by gravity = no actuation apart from possible backup actuation.		

Table A.79 (continued)

Name	Description	Unit or code list	Priority
Shut-off pressure	Maximum differential pressure when valve closed (design) For PSVs: set-point opening pressure	Pascal (bar)	Low
Valve material	Type	Carbon steel (CS), stainless steel (SST), duplex, alloy type, composite, titanium	High
Stem sealing	Type	Stuffing box, duplex, lip seal, O-ring	High
Seat design	Type of seat design	Soft seated, metal-to-metal seated	Medium
Actuation principle ^b	Actuator operating principle	Single-acting, double-acting, actuation by line/process pressure, actuation by gravity	Medium
Actuation – opening	Type of actuation force	Electrical, hydraulic, pneumatic, mechanical (spring), manual, combinations, none	High
Actuation – closing	Type of actuation force	Electrical, hydraulic, pneumatic, mechanical (spring), manual, combinations, none	Medium
Manufacturer – actuator	Name of actuator manufacturer	Specify	Low
Manufacturer – pilot valve	Name of pilot-valve manufacturer	Specify	Low
Manufacturer – solenoid valve	Name of solenoid-valve manufacturer	Specify	Low
Pilot-valve configuration	Number and configuration (applicable for pilot-operated valves only)	Specify, e.g. 1 × 3/2 (= single 3/2 pilot valve), 2 × 4/3 (= double 4/3 pilot valve)	Low
Fail-safe principle pilot valve	Fail-safe principle	Energized, de-energized	Low
Solenoid-valve configuration	Number and configuration (applicable for solenoid-operated valves only)	Specify, e.g. 1 × 3/2 (= single 3/2 pilot valve), 2 × 4/3 (= double 4/3 pilot valve)	Low
Fail-safe principle solenoid valve	Fail-safe principle	Energized, de-energized	Low
Valve fail-safe position	Fail-safe position	Fail-open, Fail-close, Fail-as-is	High
Trim type	Type (applicable for control valves only)	Noise reduction, anti-cavitation, multi-stage, single-stage	High
Valve leakage class	Specify according to applicable reference standard (e.g. for valves complying with API Spec 6D, see ISO 5208:2015)	ISO 5208:2015, Annex A, Table 4	High

^a Benign (clean fluids, e.g. air, water, nitrogen).
Moderately corrosive/erosive (oil/gas not defined as severe, sea water, occasionally particles).
Severe corrosive/erosive [sour gas/oil (high H₂S), high CO₂ content, high sand content].

^b Primary actuation principle:
1 single-acting = actuation force by gas (air) or hydraulic fluid for either opening or closing the valve;
2 double-acting = actuation force by gas (air) or hydraulic fluid for both opening and closing the valve;
3 actuation by line/process pressure or actuation by gravity = no actuation apart from possible backup actuation.

A.2.5.5 Nozzles

Table A.80 — Type classification — Nozzles

Equipment class — Level 6		Equipment type	
Description	Code	Description	Code
Nozzles	NO	Deluge	DN
		Sprinkler	SR
		Water mist	WM
		Gaseous	GA

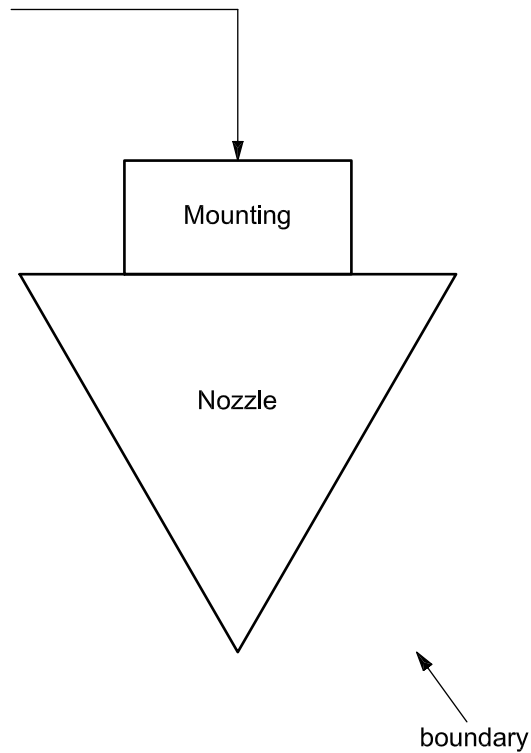

Figure A.28 — Boundary definition — Nozzles

Table A.81 — Equipment subdivision — Nozzles

Equipment unit	Nozzles		
Subunit	Nozzle	Mounting assembly	Miscellaneous
Maintainable items	Fusible bulb Nozzle body with internals Nozzle head Protective coating Screen Solder	Mounting connector Seals	Others

Table A.82 — Equipment-specific data — Nozzles

Name	Description	Unit or code list	Priority
Application	Where in the process applied	Deluge, sprinkler	High
Hazards protection	Type of protection	Electrical, Ex, fuel oil, glycol, HC gas, hydrogen gas, lubricants, methanol, combustibles, radioactivity, toxic gas, toxic liquid	High
Location on plant	Where located in the plant	Air inlet, compressor, diesel engine, drilling, electric motor, FW inlet, gas-metering, generator, header, heat exchanger, living qt., mud-processing, pigging station, pipeline, pump, separator, turbine, utility, vessel, wellhead, wellhead flowline, wellhead injection line, X-mas tree	High
Nozzle material	Specify	Brass, chrome-plated, electrode-less nickel-plated, lead-coated, stainless steel	High
Nozzle length	Specify	Millimetres	High
Nozzle width	Specify	Millimetres	High
Installation category	How installed	Concealed, horizontal sidewall, pendent, recessed, upright, vertical sidewall	Low
Fluid handled – nozzles	Main fluid only	Potable water, sea water, Inergen, CO ₂	Medium
Fluid corrosiveness/erosiveness	Classify as shown in the footnote ^a	Benign, moderate, severe	Medium
Discharge temperature	At operating condition	Degrees Celsius	Low
Flowing pressure	Specify	Pascal (bar)	Medium
Flow rate	Specify	Litres per minute	Medium
Shut-off pressure	Maximum differential pressure when valve closed (design) For safety pressure-relief valves: set-point opening pressure	Pascal (bar)	Low
Fluid temperature	Specify	Degrees Celsius	Low
Connection size	Specify	Millimetres (inches)	High
Type of nozzle end	Specify	Bolted flange, clamped flange, screwed, welded	Medium
Spray angle	Specify	Degrees	Medium
Spray type	Specify	Droplets, mist	Medium
Actuation	Specify	Fusible bulb, solder, external	Medium
Nozzle screen	Whether or not installed	Yes/No	Low
^a Benign (clean fluids, e.g. air, water, nitrogen). Moderately corrosive/erosive (oil/gas not defined as severe, sea water, occasionally particles). Severe corrosive/erosive [sour gas/oil (high H ₂ S), high CO ₂ content, high sand content].			

A.2.5.6 Lifeboats

The lifeboats addresses lifeboats mounted on offshore oil & gas facilities, and also drilling rigs. Note that lifeboats, in Arctic areas, are not addressed in this International Standard.

The diving technical equipment within self-propelled hyperbaric lifeboats is not covered by this International Standard, but by NORSOK U-100:2015.

Note that there are two types of Free fall lifeboats, drop or skid.

Table A.83 — Type classification — Lifeboats

Equipment class - Level 6		Equipment type	
Description	Code	Description	Code
Lifeboats	LB	Free fall	FF
		Davit launched	DL

Boundary

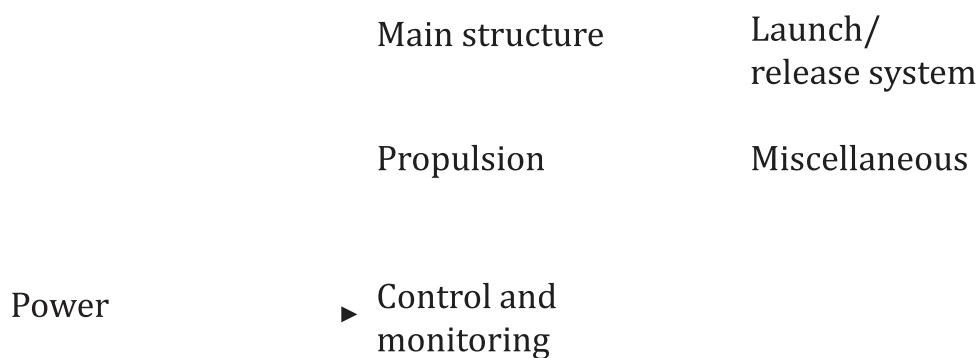

Figure A.29 — Boundary definition — Lifeboats

Table A.84 — Equipment subdivision — Lifeboats

Equipment unit	Lifeboats				
Subunit	Main structure	Propulsion	Control and monitoring	Launch/Release ^a	Miscellaneous
Maintainable items	Hull Innerliner Superstructure Seat/Seat belts Lifting/Release hook attachment Tanks ^b Doors/Hatches	Engine Gear box/ transmission Propeller shaft Propeller Steering nozzle Steering system Waterjet ^c	Air regulator Control panel ^d Lifeboat release hook Lifeboat release panel Hydrostatic interlock system ^e Limit switches ^f	Davit structure Davit winch/gear/motor Davit wire Davit winch HPU Davit control panel Hydraulic system ^g Shackles Hang-off wires Skid arrangement ^h	Communication systems Electrical system incl. lights and navigation Deluge pump/ piping/nozzles Air cylinder Battery charger Bilge pump Emergency equipment ⁱ
^a These maintainable items are located on the host facility (e.g. platform and FPSO). Note that some of these items do not apply for all types of lifeboat (ref Table A.83). This system also covers the recovery of the launched lifeboat. ^b Tanks include fuel and water tanks and other bulkheads, of various material (e.g. GRP). ^c Water-jet is seldom in use for lifeboats but is more normal for man-overboard boats (MOB). ^d This is control panel onboard the lifeboat. ^e This applies only for Davit launched lifeboats, ^f Limit switch is physically located as part of the launch/release system on the host facility. ^g Hydraulic system includes cylinders. ^h Added to cover Free Fall lifeboat that use a skid that will not give a drop straight down. ⁱ Emergency equipment includes first aid, water and food.					

Table A.85 — Equipment-specific data — Lifeboats

Name	Description	Unit or code list	Priority
Automatic release	Automatic release of lifeboat release hook	No, Yes	Medium
Breathing air capacity	Breathing air capacity	Minutes	Medium
Breathing air system	Breathing air system?	No, Yes	High
Personnel capacity	Personnel capacity (count)	Each	High
Sprinkler system	Sprinkler system?	No, Yes	High
Nautical speed rated	Rated nautical speed	Knots	Medium
Free-fall lifeboat installation height	Height above sea level	M	High

A.2.6 Subsea

A.2.6.1 Subsea production control

Table A.86 — Type classification — Subsea production control

Equipment class — Level 6		Equipment type	
Description	Code	Description	Code
Subsea production control	CS	Direct hydraulic	DH
		Direct electro-hydraulic	EH
		Multiplexed electro-hydraulic	MX
		Discrete pilot hydraulic	PH
		Sequential piloted hydraulic	SH
		Telemetric hydraulic	TH

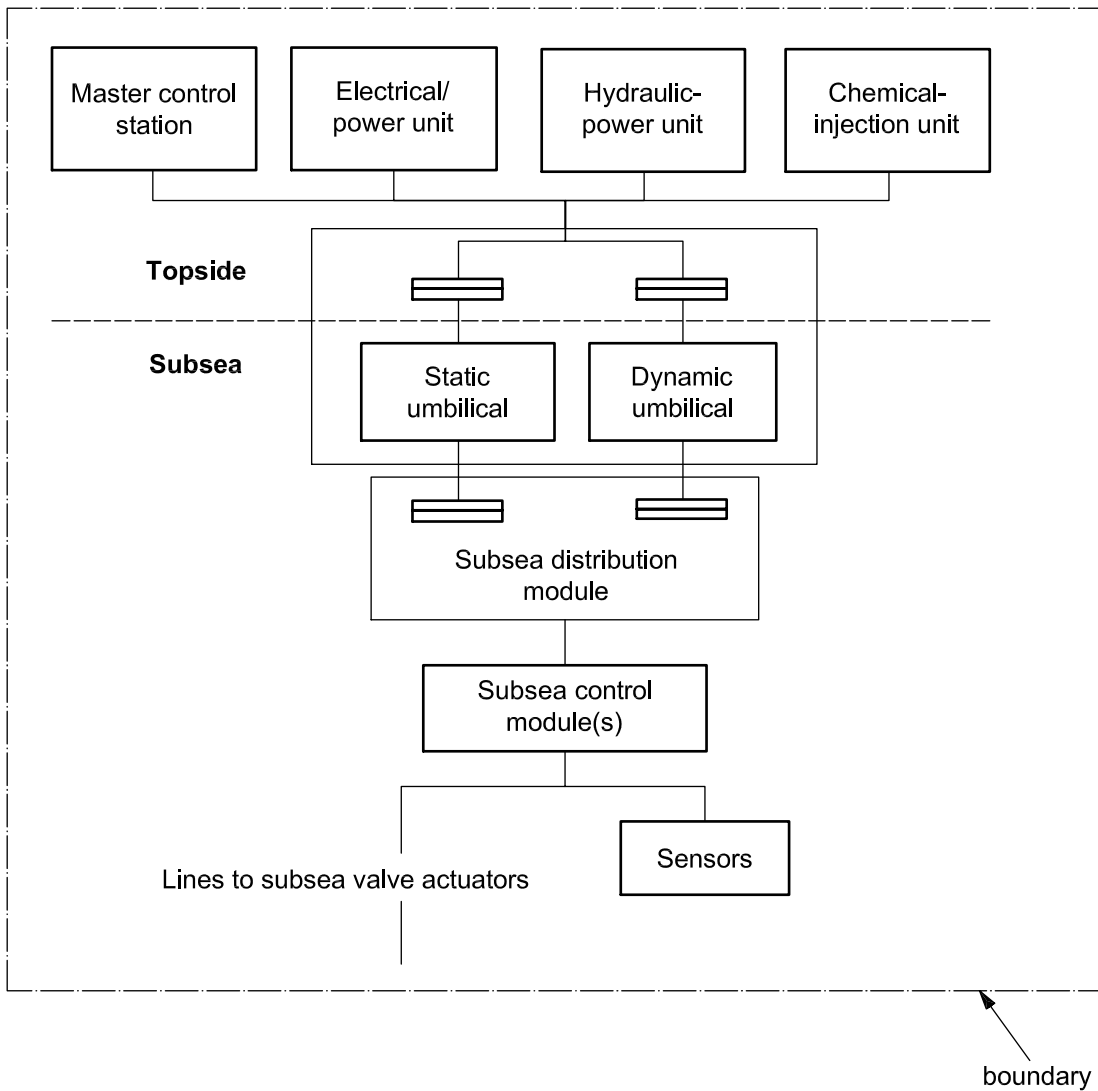

Figure A.30 — Boundary definition — Subsea production control

Table A.87 — Equipment subdivision — Subsea production control

Equipment unit	Subsea production control								
Subunit	Chemical Injection (topside)	Dynamic umbilical	Static umbilical	Electric-power unit (topside)	Hydraulic-power unit (topside)	Master control (topside)	Subsea control module ^f	Subsea distr. module ^{b, f}	Sensors ^a
Maintainable items	No breakdown	Bend restrictor Buoyancy device Hydraulic/chemical line J/I-tube seal LV power/signal line Fibre-optic line Sheath/armour Stabilizer Tension-and motion-compensation equilibrium Topside umbilical-termination unit (TUTU)	Bend restrictor Hydraulic/chemical line LV power/signal line Fibre-optic line ⁱ Sheath/armour Subsea ^h umbilical-termination unit (SUTU) Topside umbilical-termination unit (TUTU)	No breakdown	No breakdown	No breakdown	Accumulator subsea Module base plate Chemical inj. coupling Fibre-optic connector ^d Filter Hydraulic coupling LV power/signal connector ^c Subsea electronic module ^e Directional Control Valve (DCV) IWIS ^g	Accumulator subsea Subsea bypass panel Chemical inj. coupling Fibre-optic connector ^d Fibre-optic jumper ⁱ Hose Hydraulic/chemical line Hydraulic coupling Piping LV power/signal connector ^c LV power/signal jumper Subsea cabling IWIS ^g	Flow Leak Level Position Combined pressure and temperature Pressure Temperature Sand Vibration

^a Sensors inside the subunit Subsea control module (SCM) should not be mixed with those external at other subsea equipment.

^b A SUTU can be of different type, e.g. UTA (Umbilical Termination Assembly) or UTH (Umbilical Termination Head), depending on tie-in philosophy.

^c LV power/signal connectors” in SCM (or Subsea distribution module; SDM) can include penetrators, which would be of penetrator type: LV power/signal penetrator. The “LV power/signal connectors” are thus Low Voltage level (up to 1kV). These connectors can be wet or dry mate.

^d Fibre-optic connectors can include penetrators in SCM or SDM, which would be penetrator types = Fibre-optic penetrators.

^e The Subsea Electrical module (SEM) inside SCM can include penetrators, which would be of penetrator type = Electrical (instrument/signal) or Optical penetrators. Power supply handled as part of SEM. Note also that in addition to penetrators, a SEM contains other electronic and mechanical components.

^f Penetrator which is defined as “a permanent connection through a bulkhead”, might be identified as a separate maintainable item in some data collection and/or estimation.

^g Intelligent Well Interface Standard (IWIS) card(s) can be located inside SCM as a separate canister, or as part of SEM, or as a separate external module to SCM.

^h The connection between dynamic and static called a SUTU can also be a transition joint.

ⁱ During data collection precision is required to ensure sufficient information is captured enabling differentiation between failures affecting single fibre and failures affecting multiple fibres/bundle of fibres.

Table A.88 — Equipment-specific data — Subsea production control

Name	Description	Unit or code list	Priority
Well identification number	Operator description	Number or name	High
Application	Where used	HIPPS, manifold, SSIV, pump, wellhead, X-mas tree, multi-purpose	Medium
Type of control fluid	—	Oil-based, water-based	Medium
Type of control system	—	Closed, open	Medium
Redundancy	—	Yes/no	Medium

Table A.88 (continued)

Name	Description	Unit or code list	Priority
Manufacturer	Specify	Free text	High
Model type	Specify	Free text	Low
Multilateral wells	—	Yes/no	Low

A.2.6.2 Subsea wellhead and X-mas trees

NOTE Applies only for (wet) Subsea X-mas trees. The (dry) Surface X-mas tree is described in A.2.7.7.

Table A.89 — Type classification — Subsea wellhead and X-mas trees

Equipment class — Level 6		Equipment type	
Description	Code	Description	Code
Subsea wellhead and X-mas trees	XT	Vertical	VX
		Horizontal	HX

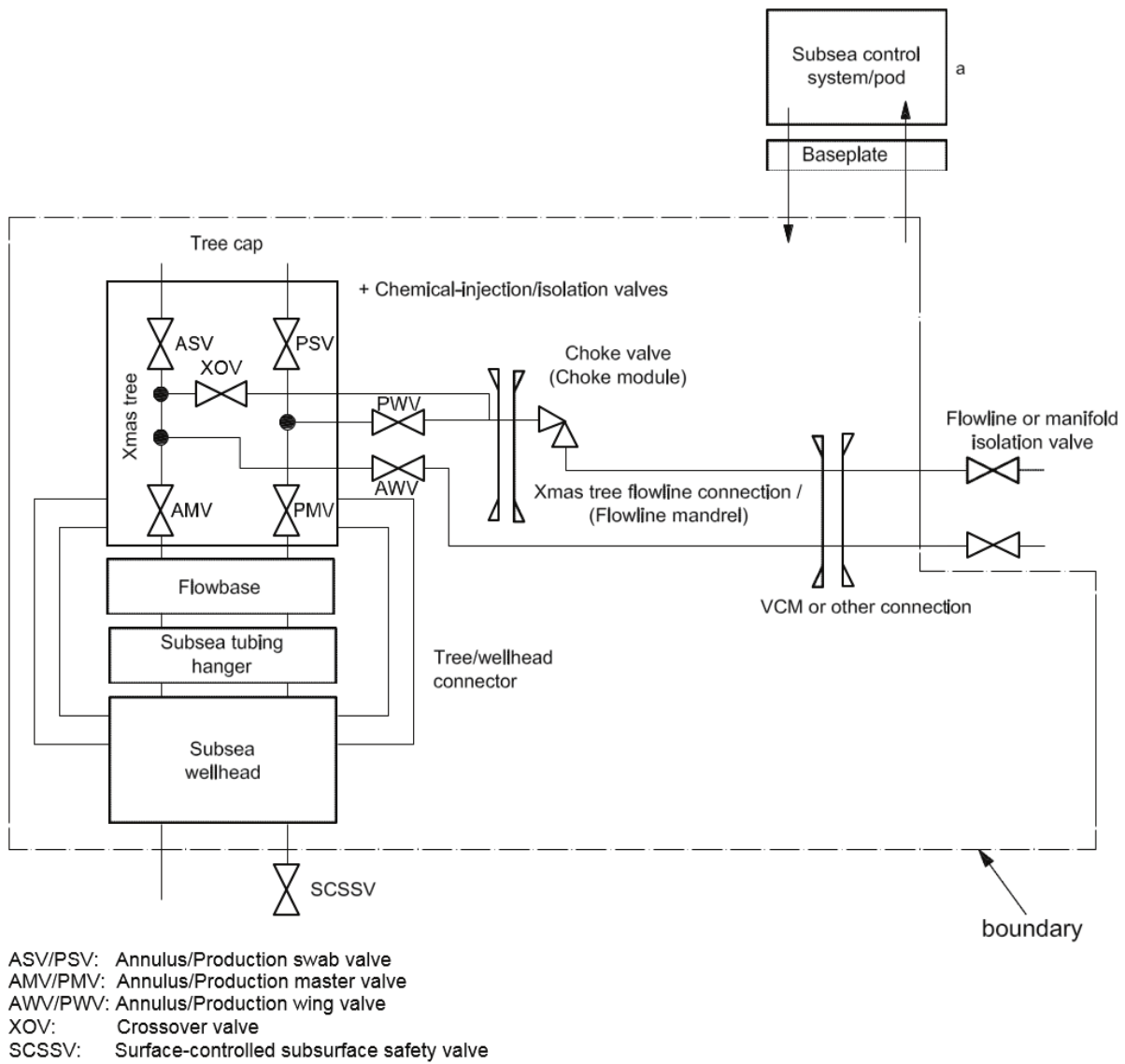

Key

^a Sensors mounted on the Subsea X-mas tree, but covered by subunit sensor in [Table A.87](#).

Figure A.31 — Boundary definition — Subsea wellhead and X-mas trees

Table A.90 — Equipment subdivision — Subsea wellhead and X-mas trees

Equipment unit	Subsea wellhead and X-mas trees					
Subunit	Subsea wellhead	Subsea X-mas tree	Tubing hanger	Flowbase	Flow control module ^a	Vertical connection module (VCM)
Maintainable items	Permanent guide base (PGB)	Chemical inj. coupling	Chemical inj. coupling	Frame	Chemical inj. coupling	VCM connector
	Temporary guide base (TGB)	Flowspool	Hydraulic coupling	Hub/mandrel ^c	Connector	Valve and actuator
	Conductor housing	Piping (hard pipe)	LV/power signal connector ^d	Valve, check	Flow loop	Control system compensation
	Wellhead housing (high-pressure housing)	High pressure cap	Tubing-hanger body	Valve, process isolation	Frame	Swivel
	Casing hangers	Hoses (flexible piping)	Tubing-hanger isolation plug	Valve, utility isolation	Hoses	Funnel guide
	Annulus seal assemblies (pack-offs)	Debris cap			Hydraulic connector	ROV-panel override system
		Tree-guide frame			Piping	ROV panel
		Connector			Valve, check	
		Internal isolation cap			Valve, choke	
		Internal tree-cap valve			Valve, control	
		Internal tree-cap plug				
		Tree cap ^b				
		Valve, check				
		Valve, choke				
	Valve, control					
	Valve, other					
	Valve, process isolation					
	Valve, utility isolation					
	Valve, workover					
^a	This can also be designated as choke module.					
^b	The tree cap, which is able to be replaced independently, can also be considered as a subunit of the X-mas tree.					
^c	This can also be designated as flowline mandrel as well as be considered as a subunit of the X-mas tree.					
^d	General carefulness with respect to sensors and interface between tubing hanger and downhole control system.					

Table A.91 — Equipment-specific data — Subsea wellhead and X-mas trees

Name	Description	Unit or code list	Priority
Well identification number	Operator description	Number or name	High
Install/retrieve guide	Guideline/guideline-less, diver-assisted and diver-less lay-away	Guideline, guideline-less	High
Well type	Production, injection	Production, injection	High
Protection type	Over-trawlable, trawl-catching, etc.	Trawl-catching, trawl-deflecting, none	High
Water depth	—	Metres	High
Design pressure	Pressure rating of wellhead and X-mas tree	Pascal (bar)	High
Artificial lift well	Type of artificial lift in the well	Gas lift, ESP, PCP, none	High
Number of connections	Number of lines connected to the tree block	Number	Low
^a	Neutral (clean fluids with no corrosive effects). Sweet [moderately corrosive/erosive (oil/gas not defined as severe, raw sea water, occasional particles)]. Sour {severely corrosive/erosive [sour gas/oil (high H ₂ S), high CO ₂ , high sand content]}.		

Table A.91 (continued)

Name	Description	Unit or code list	Priority
Control principle	Defines the control principle for X-mas tree functions and actuators	—	Low
Piggable	Specify if piggable or not	Yes/no	Low
Size of tree	Dimensions and mass	Metres, kilograms	Low
Mudline suspension system	Define whether a mudline suspension system exists	Yes/no	Low
Multilateral well	Define	Yes/no	Low
Well flow rate	Representative well flow rate (production or injection)	Specify	Medium
Fluid produced/injected	Main fluid only: oil, gas, condensate, injection water	Oil, gas, condensate, injection water, oil and gas, gas and condensate, oil/gas/ water, CO ₂ , gas and water, produced water	High
Fluid corrosiveness	Classify as shown in the footnote ^a	Neutral, sweet, sour	High
Fluid erosiveness	Erosiveness of the well fluid	Benign, clean, moderate, severe, unknown	Medium
Valve application	X-mas tree valve function	Annulus master (AMV), Annulus swab (ASV), Annulus wing (AWV), Injection wing (IWV), Injection master (IMV), Injection swab (ISV), Production master (PMV), Production swab, Production wing (PWV), Crossover (XOV)	High
Valve design class	Type of X-mas tree valve design	Ball, Butterfly, Diaphragm, Double expanding gate, Flapper, Gate, Needle, Piston, Ram, Swing	High
Valve actuation	Classify	Hydraulic, Electrical, Manual	Medium
Asphaltenes	Specify	Yes/no	Low
Scale formation	Specify	Yes/no	Low
Wax formation	Specify	Yes/no	Low
Hydrate formation	Specify	Yes/no	Low
Sand production	Specify	Yes/no	Low
^a Neutral (clean fluids with no corrosive effects). Sweet [moderately corrosive/erosive (oil/gas not defined as severe, raw sea water, occasional particles)]. Sour {severely corrosive/erosive [sour gas/oil (high H ₂ S), high CO ₂ , high sand content]}.			

A.2.6.3 Risers

Note that the equipment class Dry tree risers (e.g. for dry well completion riser tie-back when TLP's and SPAR's) riser are listed as a separate equipment class in [Table A.4](#), but is not covered by the equipment class Risers in A.2.6.3.

Table A.92 — Type classification — Risers

Equipment class — Level 6		Equipment type	
Description	Code	Description	Code
Risers	PR	Rigid	RI
		Flexible	FL

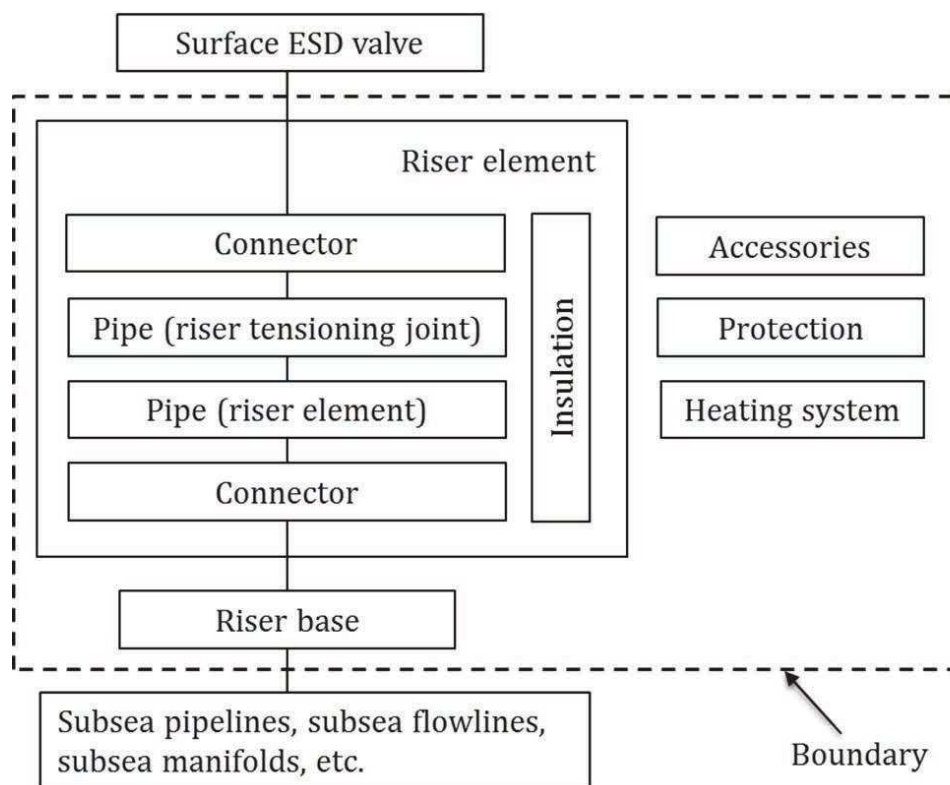

Figure A.32 — Boundary definition — Risers

Table A.93 — Equipment subdivision — Risers

Equipment unit	Risers				
Subunit	Riser	Riser base	Heating system	Protection	Accessories
Maintainable items	Connector Insulation Pipe	Gas lift Structure Valve, process isolation Valve, utility isolation	Topside part Subsea part	Anode Coating - external	Bend restrictor Buoyancy device J/I-tube seal Stabilizing and guiding equipment Tension- and motion-compensation equipment

Table A.94 — Equipment-specific data — Risers

Name	Description	Unit or code list	Priority
Well identification number	Operator description	Number or name	High
Application	What type of platform	Fixed, floating, buoy	Medium
Riser length	—	Metres	High
Working pressure	—	Pascal (bar)	Medium

^a Neutral (clean fluids with no corrosive effects).
 Sweet [moderately corrosive/erosive (oil/gas not defined as severe, raw sea water, occasional particles)].
 Sour {severely corrosive/erosive [sour gas/oil (high H₂S), high CO₂, high sand content]}.

^b Note that as per ISO/TR 12489:2013, 3.6.4 SSIV can be either an actuated valve (e.g. remotely controlled subsea valve) or non-actuated valve (e.g. subsea check valve). The control system for the subsea riser base valves will be covered by equipment class “Subsea production control”, e.g. dynamic umbilical and subsea control module, plus topsides control equipment (see A.2.6.1).

Table A.94 (continued)

Name	Description	Unit or code list	Priority
Coating	External and internal	Specify	Low
Corrosion inhibitor	—	Yes/no	Low
Temperature	Design value	Degrees Celsius	Low
Manufacturer	Specify	—	High
Gas lift	If installed or not	Yes/no	Low
Pipe diameter	—	Millimetres	Medium
Pipe material	Specify	Steel, composite, titanium, clad/lined	Medium
Protection, corrosion	Specify	Active, passive	Medium
Protection, mechanical	Specify	I-tube, J-tube, riser shaft penetration	Medium
Riser layout	Specify	Free hanging, Lazy S, lazy wave, pliant wave, steep S, steep wave	Medium
Wall thickness	Specify	Millimetres	Low
Fluid conducted	Main fluid only: oil, gas, condensate, injection water	Oil, gas, condensate, injection water, oil and gas, gas and condensate, oil/gas/water, CO ₂ , gas and water, produced water	High
Fluid corrosiveness	Classify as shown in footnote ^a	Neutral, sweet, sour	High
Asphaltenes	Specify	Yes/no	Low
Scale formation	Specify	Yes/no	Low
Wax formation	Specify	Yes/no	Low
Hydrate formation	Specify	Yes/no	Low
Sand production	Specify	Yes/no	Low
Valve application	Riser base valve function	Pipeline isolation, SSIV ^b , HIPPS	High
Valve design class	Type of riser base valve design	Side-entry ball, top-entry ball, double expanding gate (DEG), slab gate, wedge gate, check	High
^a Neutral (clean fluids with no corrosive effects). Sweet [moderately corrosive/erosive (oil/gas not defined as severe, raw sea water, occasional particles)]. Sour {severely corrosive/erosive [sour gas/oil (high H ₂ S), high CO ₂ , high sand content]}. ^b Note that as per ISO/TR 12489:2013, 3.6.4 SSIV can be either an actuated valve (e.g. remotely controlled subsea valve) or non-actuated valve (e.g. subsea check valve). The control system for the subsea riser base valves will be covered by equipment class "Subsea production control", e.g. dynamic umbilical and subsea control module, plus topsides control equipment (see A.2.6.1).			

A.2.6.4 Subsea pumps

Table A.95 — Type classification — Subsea pumps

Equipment class — Level 6		Equipment type	
Description	Code	Description	Code
Subsea pumps	SP	Centrifugal	CE
		Reciprocating	RE
		Rotary	RO

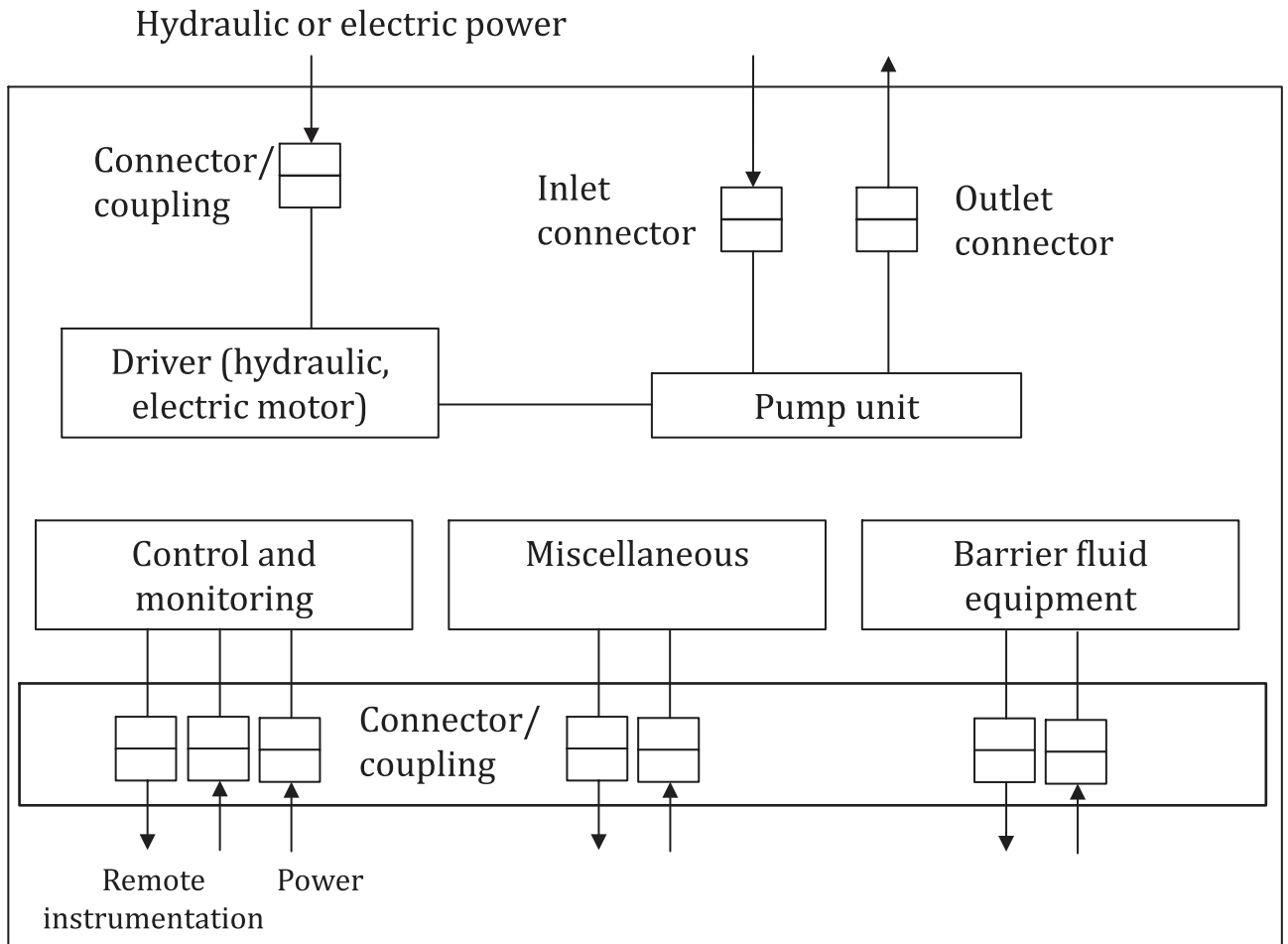

Figure A.33 — Boundary definition — Subsea pumps

Table A.96 — Equipment subdivision — Subsea pumps

Equipment unit	Subsea pumps ^a				
Subunit	Pump	Electric motor	Barrier fluid ^{b, c}	Control and monitoring	Miscellaneous
Maintainable items	Bearing, radial	Bearing, radial	Accumulator	Cable	Connector
	Bearing, thrust	Bearing, thrust	Hydraulic coupling	Junction box	Cooling/heating
	Casing	Casing	Cooling	Leak sensor	Piping
	Connector	Connector	Filter	Level sensor	Pulsation damper
	Cylinder liner	Control unit	Lubrication oil	Power supply	Purge system
	Impeller	Impeller	Piping	Pressure sensor	
	Piping	Rotor	Lubrication oil pump incl. driver	Power/signal coupler	
	Piston	Seal	Reservoir	Speed sensor	
	Seal	Stator	Valve, check	Temperature sensor	
	Shaft	Support		Vibration sensor	
	Structure, protect	Subsea electrical penetrator		Valve, other	
	Structure, support				
	Mechanical landing interface				
	Valve, control				
	Valve, process isolation				
Valve, other					

^a Note that the subsea pump includes the driving unit (electric motor) as opposed to the pumps located topsides or onshore (See A.2.2.6). The subsea pump does not include power transmission to the (subunit) electrical motor, as this will be covered by the equipment class “Subsea electrical power distribution”. It should also be noted that the equipment class “Subsea pumps” does not include “Submersible pumps” located in a seafloor caisson.

- ^b The barrier fluid equipment has four main functions:
- electric isolation (dielectric properties);
 - lubrication of bearings and seals;
 - ability to transport away heat;
 - ability to transport particles to possible filter systems.

^c The maintainable items are primarily located topsides, but some also subsea (e.g. hydraulic couplings in either end of umbilical). The barrier fluid is distributed from topsides (or from onshore) to the subsea pump via barrier fluid lines which are inside static umbilical (and possibly dynamic umbilical) and possibly via hydraulic jumpers. This equipment is defined as subunit and maintainable items within the equipment class “Subsea production control” (See A.2.6.1). Depending on the field infrastructure where the subsea pump is located, these umbilicals can already be defined. The items may be included as part of the overall barrier fluid distribution and thus added as maintainable items in the subunit “Barrier fluid”, to ensure precise reliability data collection/estimation. See also similar issues regarding electric power supply in the note (a) above.

Table A.97 — Equipment-specific data — Subsea pumps

Name	Description	Unit or code list	Priority
Well identification number	Operator description	Number or name	High
Discharge pressure – design	—	Pascal (barg.)	High
Suction pressure – design	—	Pascal (barg.)	Medium
Pump driver	Type of driver	Electric motor, turbine, hydraulic motor	High
Power – design	Driver power	Kilowatt	High
Speed	Design value	Revolutions per minute	Low
Number of stages	—	Number	Low
Pump coupling	—	Fixed, flexible, hydraulic	Low
Manufacturer	Specify	Specify	High
Model type	Specify	Specify	Low
Pump design	Design characteristic	Axial, radial, composite, diaphragm, plunger, piston, screw, vane, gear, lobe	High
Application - pump	Where applied	Booster, injection, active cooling	Medium
Fluid handled	Main fluid only: oil, gas, condensate, injection water	Oil, gas, condensate, injection water, oil and gas, gas and condensate, oil/gas/water, CO ₂ , gas and water, produced water, cooling medium	High
Fluid corrosiveness	Classify as shown in footnote ^a	Neutral, sweet, sour	High
Radial bearing type	Specify	Magnetic, roller, sliding	Low
Thrust bearing type	Specify	Magnetic, roller, sliding	Low
Shaft orientation	Specify	Horizontal, vertical	Low
Shaft seal type	Specify	Dry, gland, labyrinth, mechanical, oil, packed combined	Low
Transmission type	Specify	Direct, gear, integral	Low
^a Neutral (clean fluids with no corrosive effects). Sweet [moderately corrosive/erosive (oil/gas not defined as severe, raw sea water, occasional particles)]. Sour {severely corrosive/erosive [sour gas/oil (high H ₂ S), high CO ₂ , high sand content]}.			

A.2.6.5 Subsea electrical power distribution

Electrical power distribution system specifically excludes subsea control system power distribution. Electrical power distribution is dedicated for distribution to subsea processing equipment (e.g. multi-flow pumps, water injection pumps, and compressors) with power requirements in range MW. The electric power to control and instrumentation is part of the equipment class “Subsea production control” - see A.2.6.1.

If the electric power comes directly from onshore, the subunit “Static power cable” in A.2.6.5 will apply, and would be similar as subunit “Static power cable” in an equipment class “Submarine power cable” used for providing power from shore to offshore facility (and may have an associated dynamic power cable, if an offshore floating facility). The topsides power distribution equipment will in the former case be located onshore. The equipment class “Submarine power cable” is not currently included in this annex.

Table A.98 — Type classification — Subsea electrical power distribution

Equipment class — Level 6		Equipment type	
Description	Code	Description	Code
Subsea electrical power distribution	EP	Single consumer without subsea step- down	SU
		Single consumer with sub-sea step- down	SD
		Multiple consumer	MC

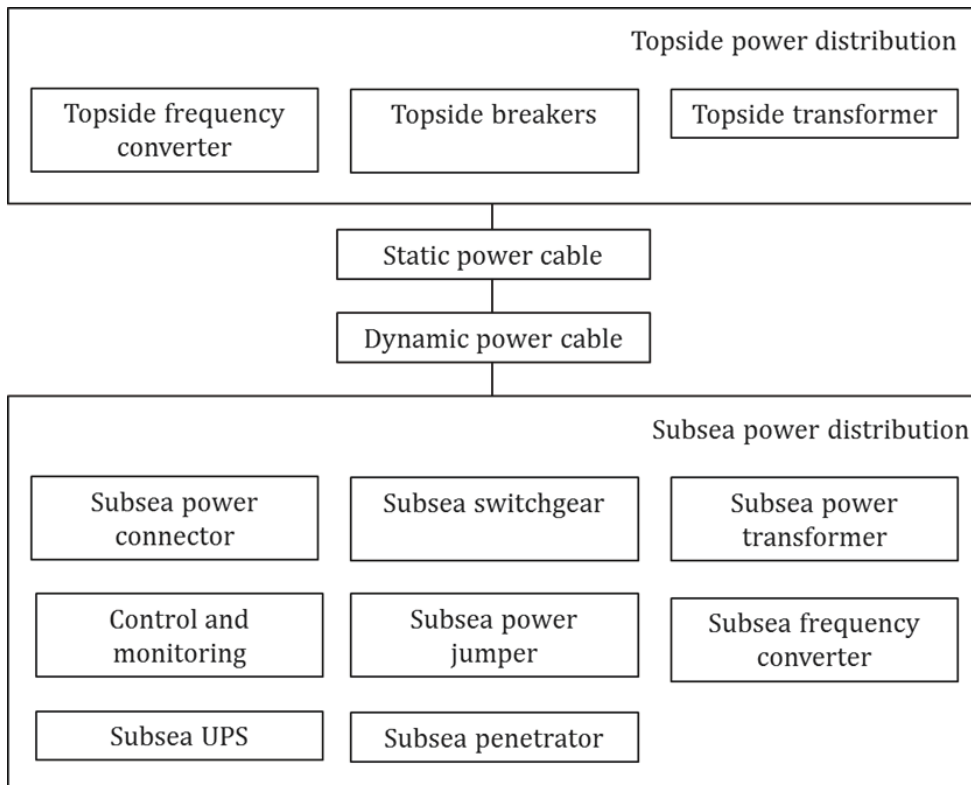

Figure A.34 — Boundary definition — Subsea electrical power distribution

Table A.99 — Equipment subdivision — Subsea electrical power distribution

Equipment unit	Subsea electrical power distribution			
Subunit	Topside power distribution equipment	Dynamic power cable ^a	Static power cable ^b	Subsea power distribution equipment ^j
Maintainable items	(No subdivision) ^l	Topside cable termination unit Tension & motion compensation equipment Bend restrictor Buoyancy device J/I-tube seal Stabilizer ^c Subsea cable termination unit Midline joint Sheath/armour HV power line Fibre-optic line ^o	HV power line Fibre-optic line ^o Factory joint Offshore joint Sheath/armour Subsea cable termination unit Topside cable termination unit ^h Onshore cable termination unit Bend restrictor Midline joint	Subsea power connector ⁿ Subsea switchgear ^e Subsea power transformer ^g Subsea penetrator ^f Subsea frequency converter ^d Subsea power jumper ^j Subsea UPS ⁱ Control and monitoring ^m
<p>^a Similar components as for the subunit Dynamic umbilical for the equipment class Subsea production control.</p> <p>^b Similar components as for the Static umbilical Subunit for equipment class Subsea production control equipment class.</p> <p>^c Anchor clamp/anchorage is part of the stabilizer.</p> <p>^d Note regarding the level of detailing. A subsea frequency converter includes subsea penetrators, and can contain contactors. However, precision needs to be dealt with in use for reliability data collection or estimation. Subsea frequency converter can be of type “pressure compensated” or “non-pressure compensated”.</p> <p>^e The maintainable item <i>Switchgear</i> will also include parts subsea protective devices.</p> <p>^f Subsea penetrators are either electrical (LV power/signal), electrical (HV) or fibre-optic penetrators. This needs to be reflected for equipment specific data on maintainable item level.</p> <p>^g Note the difference between subsea transformer as maintainable item (Level 8) and topsides Power transformer (Equipment class – level 6, as given in A.2.4.2).</p> <p>^h Applies if subsea static power cable tie-back to fixed installation.</p> <p>ⁱ This MI may be given further special detailed attention in reliability data collection or estimation by using Annex A.2.4.1 UPS.</p> <p>^j Subsea power jumper inside the subunit “Subsea power distribution equipment” can only be electrical (HV). However, inside an “overall subsea power distribution system”, also LV power/signal jumper (being electrical (LV power/signal)), or fibre-optic jumper exist. These two maintainable items appear in the taxonomy for “Subsea production control” in Table A.87, and possibly others would also be relevant, e.g. hydraulic/chemical lines may sometimes be also part of the dynamic and static power cable. Rather than introducing more subunits in Table A.99, one can use those components (appearing in various subunits) in Table A.87 that is in this case relevant for subsea power in conjunction with a reliability data collection. Note also that LV power/signal lines in dynamic & static umbilicals are not part of the equipment class “Subsea electrical power distribution”, but in the Annex A.2.6.1 “Subsea production control”. If subsea power cable also includes (is bundled with) hydraulic/chemical lines and power/signal lines, it is recommended to register data onto the subsea power cable.</p> <p>^k Generally, it is important to be aware of that some maintainable items (e.g. subsea penetrator and pressure compensator) in Subsea EPD can appear as parts (Level 9) in different MIs. Attention to this matter is needed in reliability data collection and estimation. Subsea contactor is for example not included as a maintainable item, as this would require also other components like current transformer, voltage transformer that are part of larger units like a subsea frequency converter or a switchgear</p> <p>^l The topside power distribution equipment (*) is not further subdivided as it will be covered by other equipment classes defined in this International Standard. It should be noted that equipment classes Frequency converter (topside - ref. A.2.4.4) and Power transformer (topside - ref A.2.4.2) are such equipment (*), the configuration of power transformer depends on if subsea power transformer is used subsea. Equipment class <i>Switchgear</i> (which would include topsides protective device) is also part of such equipment (*). In addition, reactive compensation equipment will exist when long subsea power cable to offshore facility or power directly from shore.</p> <p>^m The control and monitoring associated with subsea electric power distribution equipment is included in the subunit. This comes in addition to the local control and monitoring for e.g. subsea pumps – see A.2.6.4.</p> <p>ⁿ The Subsea power connector is sometimes called the HV connector, and can be dry or wet mate. Note that the electrical (LV power/signal), and fibre-optic connectors used for Subsea Power Distribution are covered by these maintainable items in Subunit “Subsea distribution module” in the taxonomy for equipment class “Subsea production control” in Table A.87.</p> <p>^o During data collection precision is required to ensure sufficient information is captured enabling differentiation between failures affecting single fibre and failures affecting multiple fibres/bundle of fibres.</p>				

Table A.100 — Equipment-specific data — Subsea electrical power distribution

Name	Description	Unit or code list	Priority
Transmission voltage ^a	0 - 9,999	kV	High
Transmission power	0 - 99,999	kVA	High
AC/DC	AC DC AC/DC	Codes	High
Transmission distance	0 - 999	km	High
Number of power consumers	0 - 99	#	High
Type of power consumers	Type of power consumers	Subsea pump, subsea compressor, subsea heater, subsea cooler	High
<p>^a Voltage is given in steps, as per IEC 60038:2009 (see below).</p> <ul style="list-style-type: none"> — LV < 1kV — MV 1 to 35kV — HV 35 to 230kV — EHV above 230kV <p>The international oil & gas industry may use different definition with respect to Extra High Voltage (EHV), High Voltage (HV), Medium Voltage (MV) and Low Voltage (LV). Reference to IEC versus IEEE/ANSI needs to be considered here to know e.g. voltage range for HV as they may be categorized differently. For other than low voltage (LV), i.e. > 1KV special national electrical regulations will apply due to HSE reasons.</p>			

A.2.6.6 Subsea pressure vessels

Table A.101 — Type classification — Subsea pressure vessels

Equipment class - Level 6		Equipment type	
Description	Code	Description	Code
Subsea pressure vessels	SV	Coalescer	CA
		Cyclone	CY
		Hydrocyclone	HY
		Scrubber	SB
		Separator	SE
		Slug catcher	SC
		Surge drum	SD

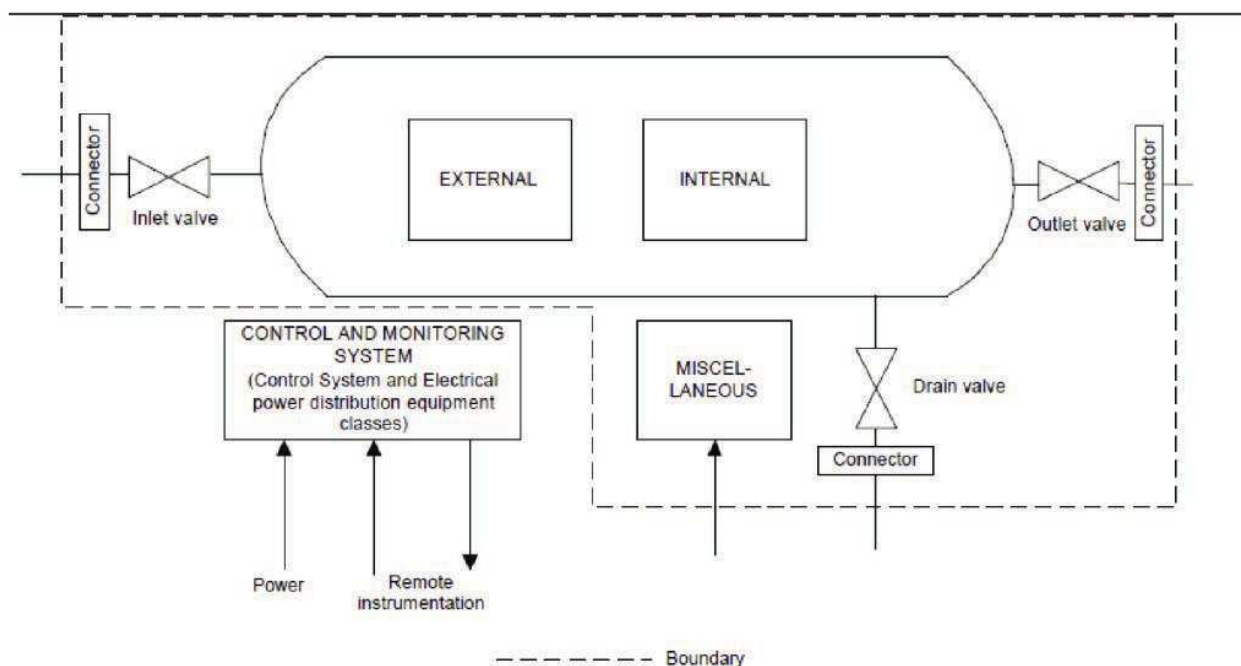

Figure A.35 — Boundary definition — Subsea pressure vessels

Table A.102 — Equipment subdivision — Subsea pressure vessels

Equipment unit	Subsea pressure vessels			
Subunit	External items	Internal items	Control and monitoring ^c	Miscellaneous
Maintainable items	Protective structure Support structure Insulation Connector Body/Shell Piping ^b Valve, check Valve, process isolation Valve, utility isolation Valve, other	Coalescer plates Baffle plates Trays Vanes Pads Demister Diverter Grid plate Heat coil Sand-trap system Distributor	Sensors ^a Valve, control	Others

^a Subsea sensors would also be covered in the Subunit “Sensors” for equipment class “Subsea production control” (See [Table A.87](#)). Such sensor would include “Multiphase meters”, “Oil in water” sensor, “Water in oil” sensor and “Fluid level sensor”. See also A.2.5.2 Input devices which describe a specific equipment class, but is meant for non-subsea applications, but may be relevant also for reliability data collection/estimation.

^b Hard pipe.

^c Control and monitoring for “Subsea pressure vessel” will be similar, but somewhat different from topsides/onshore “Pressure vessel” (see [Table A.39](#)): LV power/signal jumper and LV power/signal connector will be analogue to wiring and piping, but is covered by the subunit “Subsea distribution module” (See [Table A.87](#)).

Table A.103 — Equipment-specific data — Subsea pressure vessels

Name	Description	Unit or code list	Priority
Equipment application	Where used	Oil processing, Condensate processing, Gas (re-)injection Gas processing, Gas treatment, Water (re-)injection, Liquid/gas separation, Liquid/Gas/Solid separation	High
Retrievable	Retrievability of the subsea pressure vessel	Yes/No	High
Fluid erosiveness	Classify as shown	Clean, benign , moderate, severe	High
Fluid corrosiveness	Classify as shown	Neutral, Sweet, Sour	High
Fluid(s)	Main fluid	Gas/oil/water, gas/oil, gas/condensate, oil/water, oily water, water/glycol, methanol, chemicals	High
Liquid/gas boosting		Yes/No	Medium
Pressure - operating	Specify	Pascal (bar)	Medium
Design pressure	Specify	Pascal (bar)	High
Design temperature	Specify	Degrees Celsius	High
Temperature - operating	Specify	Degrees Celsius	Medium
Retention time	Specify	Minutes	Medium
Design throughput	Specify	Sm ³ /d	Medium
Size - diameter	External	Metres	Medium
Size - length	External	Metres	Medium
Orientation	Specify	Horizontal, vertical, spherical	Medium
Body material	Specify type or code	Free text	Low
Sand production	Specify	Yes/No	Low
Emulsions	Specify	Yes/No	Low
Hydrate formation	Specify	Yes/No	Low
Wax formation	Specify	Yes/No	Low
Scale formation	Specify	Yes/No	Low
Asphaltenes	Specify	Yes/No	Low

NOTE The equipment specific data for “Subsea pressure vessel” is similar, but also somewhat different from for a topsides/onshore “Pressure vessel (See [Table A.40](#)) due to that the pressure vessel is located at the seabed.

A.2.6.7 Subsea pipelines

Subsea pipeline transportation system covers:

- export pipeline systems between subsea well facilities (“export manifold”) and onshore terminal;
- export pipeline systems between offshore processing facilities and other offshore processing/export facilities (subsea intra-field pipelines);
- export pipeline systems between offshore facilities and onshore terminal;
- intercontinental export pipelines, between onshore terminal and another onshore terminal;
- export lines to offshore offloading systems.

The onshore part of a subsea pipeline is covered by this equipment class “Subsea pipelines”, and valves would be located subsea and/or onshore.

The in-field flowlines (with e.g. well flow, injection gas or injection water) between subsea wells and offshore processing facilities, or onto “export manifold”, are covered by the equipment class “Subsea flowlines”.

Table A.104 — Type classification — Subsea pipelines

Equipment class - Level 6		Equipment type	
Description	Code	Description	Code
Subsea pipelines	SL	Flexible	FL
		Rigid	RI

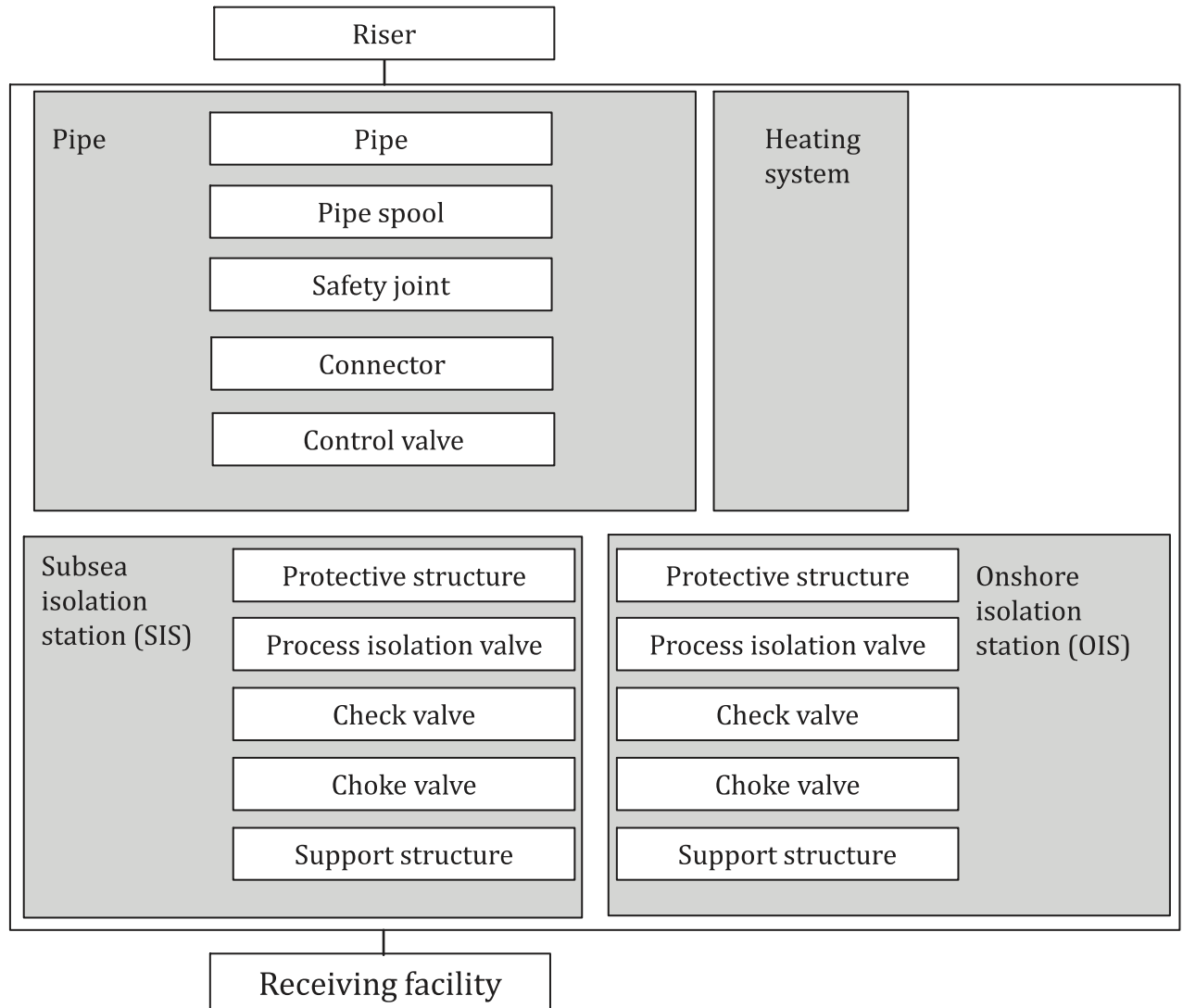

Figure A.36 — Boundary definition — Subsea pipelines

Table A.105 — Equipment subdivision — Subsea pipelines

Equipment unit	Subsea pipelines			
Subunit	Pipe	Heating system ^a	Subsea Isolation Station (SIS) ^b	Onshore Isolation Station (OIS) ^b
Maintainable items	Coating external	Subsea part	Structure - protective	Structure - protective
	Connector	Topsides part	Structure - support	Structure - support
	Sealine		Valve, process isolation ^c	Valve ^f , process isolation
	Safety joint		Valve, utility isolation	Valve, utility isolation
	Flexible pipe spool		Valve, check	Valve, check
	Rigid pipe spool		Valve, control	Valve, control
	Valve, process isolation ^d		Pig station ^e	Pig station ^e
<p>^a The heating system would normally not apply for long distance pipeline (trunkline) transport systems. In general heating system is used in in-field flowlines for non-processed well flow.</p> <p>^b Onshore isolation system (OIS) is the landfall valve station where the subsea pipeline ends into the onshore terminal. It will contain onshore process isolation valves that acts as important barriers. The subsea isolation station applies if there are subsea isolation valve(s) along the subsea pipeline routing. The SIS is a subsea manifold structure (e.g. PLEM - Pipeline End Module) with a various type of valves depending on the pipeline infrastructure. The valve design class will typically vary for these valves.</p> <p>^c If the valve is a Subsea isolation valve (SSIV), the “Valve component application” needs to be set to SSIV. SSIV is addressed in ISO 14723:2009, see also 3.6.4 in ISO/TR 12489:2013. It is sometimes called SIV. It is a specific type of process isolation valve.</p> <p>^d If the subsea pipeline has a T-connection, this will normally contains valves. The valve design class may vary.</p> <p>^e The pipeline will normally be subject to pigging, and the associated pig launcher and pig receiver (includes various components) will be located in either end of the pipeline, e.g. subsea, topsides or onshore. The pig station may also be part of the Subunit “Riser base” in the Equipment class “Risings”.</p> <p>^f Valves have a key barrier function in equipment class “Subsea pipelines” and are maintainable items within a subunit. It is however possible to use equipment class “Valves” (A.2.5.4) if data collection in more depth for dry valves is needed.</p>				

Table A.106 — Equipment-specific data — Subsea pipelines

Name	Description	Unit or code list	Priority
Application	Classify	Subsea to onshore Subsea intra-field Offshore facilities to onshore Intercontinental export pipelines Export lines to offloading	High
Type	Classify	Production, injection	
Maximum water depth	Specify	Metres	Medium
Pipeline length	-	Metres	High
Pipeline diameter	Nominal outer diameter (OD)	Millimetre	Medium
Fluid conducted	-	Oil, gas, condensate, oil and gas, gas and condensate, oil/gas/water, CO ₂	High
<p>^a Note that as per ISO/TR 12489:2013, 3.6.4 SSIV can be either an actuated valve (e.g. remotely controlled subsea valve) or non-actuated valve (e.g. subsea check valve). The control system for the subsea pipeline valves will be covered by equipment class “Subsea production control”, e.g. static umbilical and subsea control module, plus topsides control equipment (see A.2.6.1).</p>			

Table A.106 (continued)

Name	Description	Unit or code list	Priority
Pipeline buried	Specify if part or entire pipeline is buried.	Yes/No	High
Number of T-connections	Specify	Number	Medium
Heating system	-	Yes/No	High
Fluid corrosiveness	Classify	Clean Benign Moderate Severe	High
Fluid erosiveness	Classify	Clean Benign Moderate Severe	Medium
Pressure – design	Design pressure	Pascal (bar)	High
Pressure – operating	Operating pressure	Pascal (bar)	Medium
Temperature – design	Design temperature	Degrees Celsius	Medium
Valve application	Pipeline valve function	Pipeline isolation SSIV ^a	High
Valve design class	Type of pipeline valve design	Side-entry ball, top-entry ball, double expanding gate (DEG), slab gate, wedge gate, check	High
Valve actuation	Classify	Hydraulic, Electrical, Manual	High
Valve location	Specify location of pipeline valves	Subsea, topside, landfall/ onshore	High
Valve fail-safe position	Fail-safe-position	Fail-open, Fail-close, Fail-as-is	High
^a Note that as per ISO/TR 12489:2013, 3.6.4 SSIV can be either an actuated valve (e.g. remotely controlled subsea valve) or non-actuated valve (e.g. subsea check valve). The control system for the subsea pipeline valves will be covered by equipment class “Subsea production control”, e.g. static umbilical and subsea control module, plus topsides control equipment (see A.2.6.1).			

A.2.6.8 Subsea valve issues

In this International Standard, it is distinguished between the valves used on subsea equipment and the topside valves, such as used on Surface wellheads and X-mas trees. The collection of RM data for the subsea valves should reflect the characteristics of the valves based on the so-called valve design class (i.e. type of valve; corresponds to equipment type in [Table A.77](#)) and the valve application (i.e. the function of the valve). Examples of subsea valve applications are given below:

- Flowline isolation: Subsea valves which isolates infield flowline system, e.g. a valve located on a PLEM or a T-connection.
- Manifold isolation: Subsea valve located on a production/injection manifold and which has a barrier function, e.g. a branch valve or a header valve.
- Pipeline isolation: Valves which isolates the pipeline transportation system, and valves could be located subsea or onshore.
- HIPPS: See definition in ISO/TR 12489:2013, 3.6.3.
- SSIV: See definition in ISO/TR 12489:2013, 3.6.4.

A.2.7 Well completion

Valves used on well completion equipment are considered as specific valves within the taxonomy examples shown in this equipment class. Valves used on surface wellhead and X-mas trees are considered as topside valves (see A.2.5.4).

A.2.7.1 Item categories

Well completion equipment in this context refers to equipment below wellhead level. All major completion equipment items are included, from tubing hanger at the top end to equipment at the bottom of the well.

The following subunits are defined for well-completion equipment:

a) Casing

The casing subunit is included to store information on individual casing string maintainable items and associated casing failures. The casing maintainable items represent full lengths of individual casing sections and do not represent individual items threaded into the casing string. Sealing elements that are designed to seal off against leakage of hydrocarbons between the various sections of casing string (casing pack-offs) are not included. Also included in the casing subunit are maintainable items which are set inside the wellbore to isolate the wellbore from potential leakages of well effluents and which cover the entire wellbore. Casing external cement and or other material which is set casing externally to isolate against flow of well effluents/formation fluids is also considered as casing maintainable items.

b) Completion string

Completion string maintainable items are defined as items that are all integral parts of the conduit ("string") used for production or injection of well effluents. The string is built by screwing together a variety of equipment subunits.

c) Insert

The insert subunit consists of maintainable items which can be attached (set) inside the completion string. A typical example is the combination of a lock and wireline-retrievable downhole safety valve set inside a safety valve nipple.

d) Downhole power/control/monitoring

The downhole control/power/monitoring subunit consists of maintainable items which are used to provide power, control or monitoring functions to maintainable item(s) which are categorized under other well completion subunit(s).

A.2.7.2 Equipment specifications

Table A.107 — Equipment subdivision — Downhole well completion

Equipment unit	Downhole well completion				
Subunit	Casing	Completion string	Insert	Downhole power/control/monitoring	
Maintainable items	Casing	Tubing hanger	Gas lift valve (GLV) ^c	Electric-connector, downhole gauge	
	Cement	Tubing	Dummy GLV	Electric-connector, tubing hanger	
	Casing hanger	Flow coupling	WR-SCSSV ^a	Downhole control module	
	Liner	TR-SCSSV ^a	WR Bridge plug	Hydraulic control line	
	Liner hanger	Annulus safety valve	Chemical injection valve	Wellhead penetrator	
	Liner hanger/packer	Sliding sleeve		Hanger penetrator	
	Permanent bridge plug	Inflow control device	Electrical submersible pump ^b		Packer penetrator
			Hydraulic submersible pump		Power cable
			Sidepocket mandrel		Signal/instrument cable
			Inflow control valve		
			Seal assembly		
			Permanent gauge		
			Production packer		
			Downhole packer/hanger		
			Autonomous control device (AICD)		
			Nipple for wireline SCSSV		
	Fracturing sleeve				
Fracturing plug					

^a This equipment is also defined as a separate equipment class “DHSV” – see A.2.7.5.

^b This equipment is also defined as a separate equipment class “ESP” – see A.2.7.6.

^c Note relation to ISO 16530-1:—, Annex S.

Table A.108 — Equipment-specific data — Downhole well completion

Name	Description	Unit or code list	Priority
Manufacturer ^a	Specify	Text	High
Model name ^a	Give unique item model designation	Specify	High
Manufacturers part number ^a	Provide identifier which uniquely identifies equipment with identical design attributes	Text/numeric	High
Serial number ^a	Provide serial number which uniquely identifies equipment (on a per equipment basis)	Text	High/medium
Nominal size	Specify nominal size (size class) of equipment	mm or feet	Medium
Length	Provide length for any tubular equipment	Meters or feet	High

^a Manufacturer part number and serial number reflect in more detail the unique equipment identification number mentioned in [Table 5](#). Manufacturer and model name are also included in [Table 5](#).

Table A.108 (continued)

Name	Description	Unit or code list	Priority
Setting Depth	Provide setting depth as measured depth (MD) and true vertical depth (TVD) relative to rotary kelly bushing (RKB) for all equipment with a well barrier element function	Meters or feet	High
Metal type	Specify metal type used for equipment's flow exposed parts	Specify	Medium
Elastomer type	Specify elastomer type relevant equipment's with packer/sealing element	Specify	Medium
Working pressure	Maximum designed working pressure	Bar or psi	High
Working temperature	Maximum designed working pressure	Degrees C or F	High
^a Manufacturer part number and serial number reflect in more detail the unique equipment identification number mentioned in Table 5 . Manufacturer and model name are also included in Table 5 .			

An example of data collection format with associated data field definitions and registration alternatives is shown for Downhole safety valves in A.2.7.5.

A.2.7.3 Shale gas and shale oil completion

[Table A.107](#) contains general completion equipment. This equipment is also applicable for shale gas/oil completions.

A.2.7.4 SAGD completion

[Table A.107](#) contains general completion equipment. This equipment is also applicable for SAGD (Steam Assisted Gravity Drainage) completions. Guidelines for evaluating casing connections for high-temperature post-yield applications (such as SAGD) are given in Thermal Well Casing Connection Evaluation Protocol (TWCCEP) in ISO/PAS 12835:2013.

A.2.7.5 Downhole safety valves (DHSV)

This valve is available in two main types:

- a) tubing-retrievable installed as an integral part of the tubing/completion string;
- b) wireline-retrievable run on wireline toolstring for installation inside the tubing/completion string, set in a dedicated landing nipple/profile.

An example of data collection format with associated data field definitions and registration alternatives is shown for Downhole safety valves below.

Table A.109 — Tubing-retrievable, surface-controlled subsurface safety valve (TR-SCSSV)

Item: Tubing safety valve (TR)		Category: String item	Priority
Name	Description	Unit or code list	
Model	Give unique item model designation	Characters	High
Part number (operator)	—	—	Medium
Part number (manuf.)	—	—	High
Manufacturer	—	All major oilfield equipment manufacturers	High
Effective length	Length occupied by the item in the string, exclusive of pin/box	Metres	High

Table A.109 (continued)

Item: Tubing safety valve (TR)		Category: String item	Priority
Name	Description	Unit or code list	
Valve type	—	Tubing-retrievable Tubing-retrievable with wireline-retrievable brain Other Unknown	Medium
Closure principle	—	Ball Flapper (conventional) Flapper (curved) Poppet Other Unknown	Medium
Valve configuration	—	Single valve (s.v.) Single valve with insert capability within valve Single valve with separate nipple/control line for insert valves Upper valve in “hot” backup tandem concept Lower valve in “hot” backup tandem concept Upper valve in “cold” backup tandem concept Lower valve in “cold” backup tandem concept Upper valve in hybrid tandem concept	Low
Equalizing feature	—	With equalizing feature Without equalizing feature Unknown	Low
Nominal size	—	—	High
Maximum OD	—	—	Medium
Minimum ID	—	—	Medium
Pressure rating	—	—	Low
Piston type	—	Rod Concentric Rod and concentric Other Unknown	High
Number of pistons	Total number of pistons in valve.	Numeric	Low
Number of control lines	Total number of control lines attached to valve	Numeric	Low

Table A.109 (continued)

Item: Tubing safety valve (TR)		Category: String item	Priority
Name	Description	Unit or code list	
Secondary control line function	—	Not installed Balance line Permanent lockout Temporary lockout Normal operation Other Unknown	Low
Seal configuration and type	Describe configuration and materials used in dynamic and static seals	Character field	Low
Material spec. for — closure device — seat — flowtube/piston	Material used for the most vital valve parts. 'Seat' here means seat for closure device.	Code list of metallic materials	High
Control principle	—	Hydraulic Hydraulic with nitrogen charge as add-on power source Hydraulic with balance line for deep setting Electromagnetic with downhole power source Solenoid-operated with electric cable Other Unknown	Medium
Remarks	—	Character field	Low

Table A.110 — Wireline-retrievable (WR) type DHSV/WR-SCSSV

Item: Downhole safety valve (WR)		Category: Inserted item	Priority
Name	Description	Unit or code list	
Model ^a	Give unique item model designation	Characters (25)	High
Part number (operator)	—	—	Medium
Part number (manuf.) ^a	—	—	High
Manufacturer ^a	—	All major oilfield equipment manufacturers	High
Length	—	Metres	High
Closure principle	—	Ball Flapper (conventional) Flapper (curved) Poppet Other Unknown	Medium

^a Manufacturer part number and serial number reflect in more detail the unique equipment identification number mention in [Table 5](#). Manufacturer and model name is also included in [Table 5](#).

Table A.110 (continued)

Item: Downhole safety valve (WR)		Category: Inserted item	Priority
Name	Description	Unit or code list	
Valve configuration	—	Single valve (s.v) Single valve with insert capability within valve Single v. with sep. nipple/contr.l. for insert v. Upper valve in “hot” backup tandem concept Lower valve in “hot” backup tandem concept Upper valve in “cold” backup tandem concept Lower valve in “cold” backup tandem concept Upper valve in hybrid tandem concept	Low
Equalizing feature	—	With equalizing feature Without equalizing feature Unknown	Low
Nominal Size	—	—	High
Maximum OD	—	—	Medium
Minimum ID	—	—	Medium
Pressure rating	—	—	Low
Piston type	—	Rod Concentric Rod and concentric Other Unknown	High
Number of pistons	Total number of pistons in valve	Number	Low
Number of control lines	Total number of control lines attached to valve	Number	Low
Secondary control line function	—	Not installed Balance line Permanent lockout Temporary lockout Normal operation Other Unknown	Low
Seal configuration and type	Describe configuration and materials used in dynamic and static seals	Character field	Low

^a Manufacturer part number and serial number reflect in more detail the unique equipment identification number mention in [Table 5](#). Manufacturer and model name is also included in [Table 5](#).

Table A.110 (continued)

Item: Downhole safety valve (WR)		Category: Inserted item	Priority
Name	Description	Unit or code list	
Material spec. for — closure device — seat — flowtube/piston	—	Code list of metallic materials	High
Control principle	—	Hydraulic Hydraulic with nitrogen charge as add-on power source Hydraulic with balance line for deep setting Electromagnetic with downhole power source Solenoid-operated with electric cable Other Unknown	Medium
Remarks	—	Character field	Low
^a Manufacturer part number and serial number reflect in more detail the unique equipment identification number mention in Table 5 . Manufacturer and model name is also included in Table 5 .			

A.2.7.6 Electrical submersible pumps

Well deployed pumps entitled “Electrical submersible pumps” (ESP) can have different applications:

- a) onshore well;
- b) topsides well (dry tree completion);
- c) subsea well (subsea well completion);
- d) seafloor (Caisson, e.g. seafloor boosting pump);
- e) horizontal pump system (HPS), ESP used to fulfil a pump function topsides/onshore.

All above applications are addressed in ISO 15551-1:2015, except HPS, which is addressed in API RP 11S.

Hydraulic submersible pumps (HSP) is another type of pump located downhole, primarily for subsea, but is not covered in this International Standard. Likewise, Progressive Cavity Pumps (PCP) are located downhole, but only in onshore applications and is not covered in this International Standard. Some further technical details are given in ISO 15136-1:2009.

The seafloor ESP (item 4) is in principle similar to a subsea pump described in equipment class Subsea pumps (in A.2.6.4), but it is recommended to use this A.2.7.6 for RM data collection for the seafloor ESPs.

The classical or conventional installation is illustrated in [Figure A.37](#) where the ESP unit is run on the tubing string and is submerged in well fluids. The electric submersible motor is at the bottom of the unit and is cooled by the wellstream passing by its perimeter. It is connected to the seal section. On top of the seal section a pump intake or gas separator/handler is situated which allows well fluids to enter the centrifugal pump and, at the same time, can remove/handle free gas from the wellstream.

Liquid is lifted to the surface by the multistage centrifugal pump, the heart of the ESP system.

Motor Power is transmitted to the submersible motor by clamping a specially constructed three-phase ESP electric power cable to the production tubing. This cable needs to be of rugged construction to prevent mechanical damage, and able to retain its physical and electrical properties when exposed to hot liquids and gasses in oil wells.

Table A.111 — Type classification — Electrical submersible pumps

Equipment class — Level 6		Equipment type	
Description	Code	Description	Code
Electrical submersible pumps	ESP	Centrifugal	CE
		Rotary	RO
		Alternative current	AC

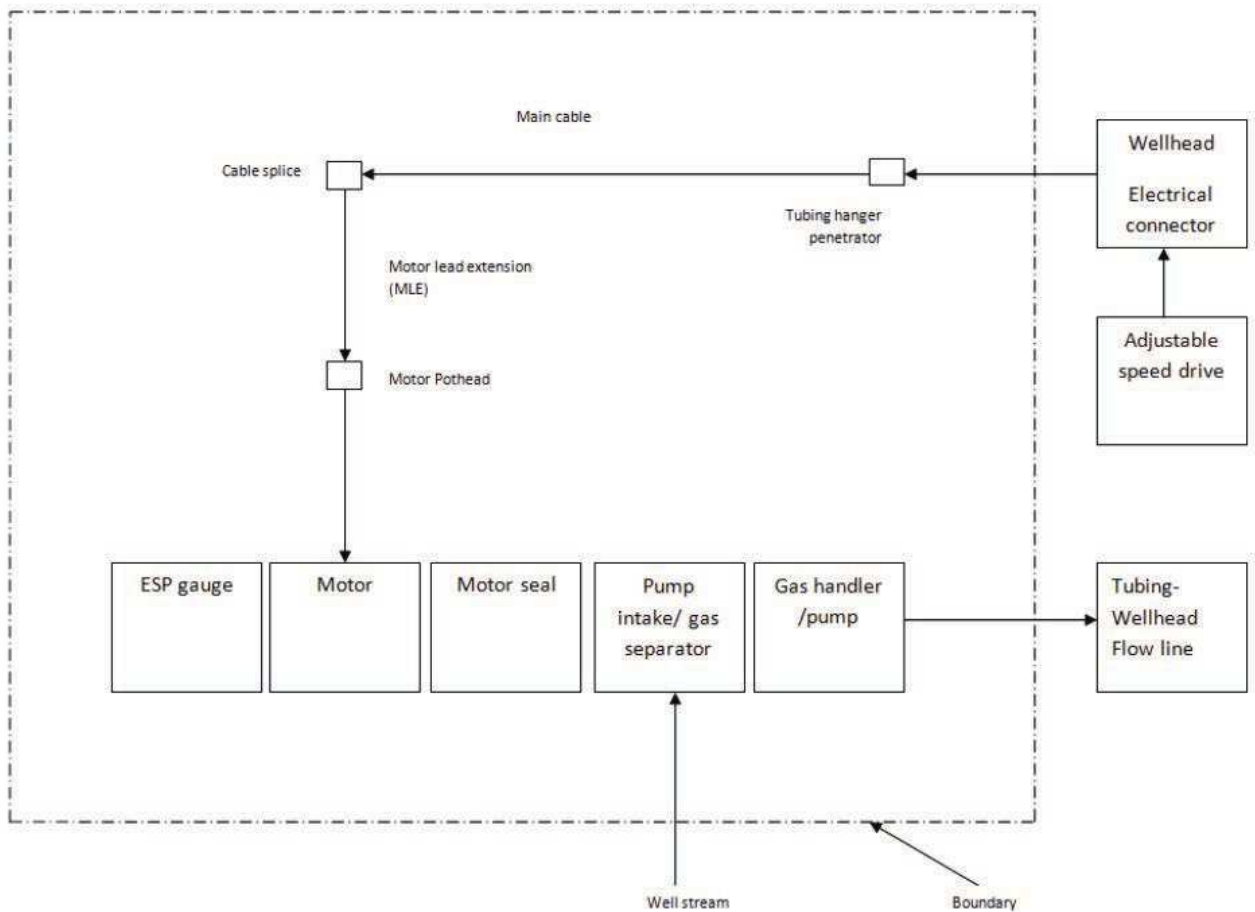

Figure A.37 — Boundary definition — Electrical submersible pumps

ESP pumps are commercially available in different capacities from 100 to around 120,000 bpd of liquid production rate and in outside diameters from around 3 inches up to 12 inches.

5000 Psi of lift or equivalent kinetic energy can be created by an ESP.

Table A.112 — Equipment subdivision — Electrical submersible pumps

Equipment unit	Electrical submersible pumps					
Subunit	ESP cable	ESP motor	ESP pump	ESP pump intake ^a	ESP seal	
Maintainable items	Main power cable	Base	Base	Base	Bag chamber	
	Motor lead extension	Coupling	Coupling	Coupling	Base	
	Packer penetrator	Filter	Diffusers	Diffusers	Coupling	
	Pigtail	Head	Head/Discharge	Discharge ports/screens	Head	
	Pothead connector	Housing	Housing	Head	Housing	
	Splice	Oil	Impellers	Housing	Labyrinth chamber	
	Wellhead penetrator	O-ring	O-rings	O-rings	Impellers	Mechanical seals
		Rotor Bearing	Rotor	Screens	Inducer section	Oil
			Rotors	Shaft	Intake pots/screens	O-ring
			Shaft	Shaft support bearings	O-rings	Relief valve
			Stator	Snap rings	Radial bearings	Shaft
			Thrust bearing	Thrust washers	Separation section/rotor	Thrust bearing
			Varnish		Shaft	
			Down hole sensor		Shaft support bearings	
				Snaps rings		
				Thrust washers		

^a ESP pump intake includes gas separator and gas handler.

Table A.113 — Equipment-specific data — Electrical submersible pumps

Name	Description	Unit or code list	Priority
Well identification number	Operator description	Number or name	High
Model type	Specify	Specify	Low
ESP Application	Type of application	Onshore well Topsides well (dry tree completion) Subsea well (subsea well completion) Seafloor (Caisson) Horizontal pump system (HPS)	High
Fluid corrosiveness	Neutral, Sweet, Sour	Specify	High
Fluid handled	Main fluid only: oil, gas, condensate, injection water	Oil, gas, condensate, injection water, oil and gas, gas and condensate, oil/gas/water, CO ₂ , gas and water, produced water	High
Shaft power rating	All, where applicable	Horse power HP	High
Shaft coupling rating	All, where applicable	Horse power HP	High
Maximum flow capacity rating	Bolt on discharge head	Blpd	Medium
Pressure rating	Bolt on discharge head	Psi	High

Table A.113 (continued)

Name	Description	Unit or code list	Priority
Design performance curves – water only	Pump and gas handler	Pump curve	Low
Maximum GVF rating	Pump and gas handler	%	Medium
Pump stage thrust	Pump and gas handler	Pounds, lbs	High
Housing pressure rating	Pump and gas handler	Psi	High
Maximum flow capacity rating	Bolt on intake	Blpd	Low
Design performance curve	Mechanical gas separator	Performance Curve	Low
Volume contraction capacity	Seal chamber section	Litres	High
Operation deviation limits	Seal chamber section	Specify [numeric value]	High
Thrust load bearing capacity	Seal chamber section	Pounds, lbs	High
Minimum operating speed for thrust bearing	Seal chamber section	Revolutions per minute, rpm, or Frequency	Low
Number and severity of pressure cycles	Seal chamber section	Specify	High
Horsepower requirement	Seal chamber section	HP	High
Motor performance parameters	Motor	Performance curve	High
Motor voltage for minimum current	Motor	Amps	High
Motor winding temperature rise	Motor	Degrees Celsius	High
Motor operating internal temperature limits	Motor	Degrees Celsius	High
Locked rotor current, torque and power factor	Motor	Amps	High
Voltage rating	Power cable and MLE	Volt	High
Temperature rating	Power cable and MLE	Degrees Celsius	High
Ampacity coefficients	Power cable and MLE	Specify [numeric value]	High
Conductor Size	Power cable and MLE	Millimetres	High
Acceptable minimum bending rating	Power cable and MLE	Metres	High
Voltage rating	Pothead	Volt	High
Temperature rating	Pothead	Degrees Celsius	High
Ampacity coefficients	Pothead	Amps	High
Differential pressure performance	Pothead	Psi	High
Thermal cycling performance	Pothead	N/A	High

A.2.7.7 Surface wellhead and X-mas trees

The surface X-mas tree could have different applications:

- X-mas tree on a TLP or SPAR platform;

- X-mas tree on a fixed offshore platform;
- X-mas tree on an onshore facility.

Note that control and monitoring is part of the surface X-mas trees, but not a part of subsea X-mas trees (see A.2.6.2).

This equipment class does not cover onshore wellheads with pump jacks installed as they do not use X-mas trees.

The equipment class Valves (see A.2.5.4), may be used to collect more detailed data on safety and production critical valves in the X-mas tree.

Table A.114 — Type classification — Surface wellhead and X-mas trees

Equipment class - Level 6		Equipment type	
Description	Code	Description	Code
Surface wellhead and X-mas trees	WD	Vertical	VE
		Horizontal	HO

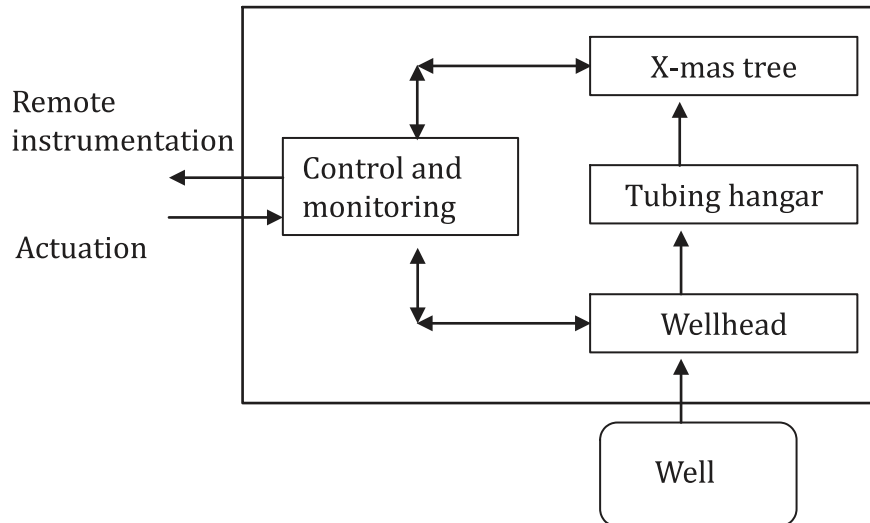

Figure A.38 — Boundary definition — Surface wellhead and X-mas trees

Table A.115 — Equipment subdivision — Surface wellhead and X-mas trees

Equipment unit	Surface wellhead and X-mas trees			
Subunit	Wellhead	Tubing hanger	X-mas tree ^{d, g}	Control and monitoring
Maintainable items	Annulus seal assemblies (Pack-offs) Casing hangers Conductor housing Control line exit block/chemical inj. block Wellhead housing	Chemical injection coupling Hydraulic coupling (termination in control line block) Power/signal coupler El. fiber (termination in control line block) Tubing-hanger body Tubing-hanger isolation plug Tubing hanger seals Back pressure valve Tubing head spool ⁱ	Tree caps Tree loops/flowlines Tree/wellhead connector X-mas tree/flowline connection (interface point) ^f Valve, check Valve, choke ^c Valve, process isolation ^{a, e} Valve, utility isolation ^{b, h} Valve, other	Control panel ^j Hydraulic instrument tubing Electric instrument tubing Pressure indicator Pressure transmitters Limit switch Temperature sensors
<p>^a Process isolation valves will include Master valves (LMV & UMV), Production wing valve (PWV), Swab valve (SV), Annulus valve(s) and Kill valve (KV).</p> <p>^b Utility isolation valves will include Chemical injection/isolation valves.</p> <p>^c For surface X-mas tree, chokes would not normally be part of the X-mas tree. Thus such maintainable item should be treated in addition, as part of the Equipment class “Valves”.</p> <p>^d Different annulus valves and these will have a function for each annulus, e.g. annulus A (between tubing and production casing) has most requirements.</p> <p>^e There are normally two master valves, whereof one is normally manually operated and one is actuator operated. There could also be two actuated valves.</p> <p>^f The downstream battery limit is the flange connection on the PWV.</p> <p>^g Valves have a key barrier function in a X-mas tree, and is thus – in same way as equipment class “Sub-sea X-mas tree” (see A.2.6.2) – maintainable items within a subunit. It is however possible to use equipment class “Valve” (A.2.5.4) if data collection in more depth for surface valves is needed.</p> <p>^h This includes chemical/hydraulic valves etc.</p> <p>ⁱ If tubing head spool is a separate maintainable item.</p> <p>^j Control panel includes control valves.</p>				

Table A.116 — Equipment-specific data — Surface wellhead and X-mas trees

Name	Description	Unit or code list	Priority
Well identification no	Well identification no - operator description	Specify	High
Well function	Function of the well	Production, injection, disposal	High
Design pressure	Pressure rating of wellhead and X-mas tree	Pascal (bar)	High
Artificial lift well	Type of artificial lift in the well	Gas lift, ESP, PCP, none	High
<p>Note 1: The type of actuation for the relevant valves should be described using the equipment specific data, as for equipment class Valves, see Table A.79.</p> <p>Note 2: For artificial lift, equipment class ESP will provide information. For gas lift, equipment class Downhole well completion will provide information, see A.2.7.</p>			

Table A.116 (continued)

Name	Description	Unit or code list	Priority
Mudline suspension system	Define whether a mudline system suspension exists	Yes/no	Low
Type of well	Type of tie-back solution	Offshore, SPAR, TLP, Onshore, I, HPHT, SAGD, Shale gas, Shale oil	High
Wellhead flowing pressure	Representative operational wellhead flowing pressure	Psi	Low
Wellhead flowing temperature	Representative operational wellhead flowing temperature	Degrees Celsius	Low
Well flow rate	Representative well flow rate (production or injection)	Specify	Medium
Fluid produced / injected	Fluid produced / injected	Air, chemicals, condensate, crude oil, flare gas, freshwater, fuel gas, gas, gas+condensate, gas+oil, gas+oil+water, combined hydrocarbons, methanol, nitrogen, oil, oil+water, oily water, sea water, treaded sea water, steam, unknown, water/glycol	High
Control principle	Defines the control principle for X-mas tree (valve) functions and actuators	Note 1	High
Fluid corrosiveness	Fluid corrosiveness	Benign, clean, moderate, severe, unknown	Medium
Fluid erosiveness	Erosiveness of the well fluid	Benign, clean, moderate, severe, unknown	Medium
Valve application	X-mas tree valve function	Swab (SV), Production wing (PWV), Kill (KV), Upper master (UMV), Lower master (LMV), Annulus (AV)	High
Valve design class	Type of valve design	Ball, Butterfly, Diaphragm, Double expanding gate, Flapper, Gate, Needle, Piston, Ram, Swing	High
<p>Note 1: The type of actuation for the relevant valves should be described using the equipment specific data, as for equipment class Valves, see Table A.79.</p> <p>Note 2: For artificial lift, equipment class ESP will provide information. For gas lift, equipment class Downhole well completion will provide information, see A.2.7.</p>			

A.2.7.8 Production/injection data

Operational data that should be collected for well-completion equipment are listed in [Table A.117](#). The data are well-specific and provide a generic reference to the working environment for all equipment in the well. The production/injection data should be collected on a monthly basis.

Table A.117 — Production/injection operational data

Data	Description	Unit or code list
Year	—	—
Month	—	—
Wellhead pressure	Flowing wellhead pressure	Pascal (bar)
Wellhead temperature	Temperature at wellhead under flowing conditions	Degrees Celsius
Daily flow, gas	Representative daily flow of gas	Standard cubic metres per day
Daily flow, oil	Representative daily flow of oil	Standard cubic metres per day
Daily flow, condensate	Representative daily flow of condensate	Standard cubic metres per day
Daily flow, water	Representative daily flow of water	Standard cubic metres per day
<p>^a Grams per metric tonne is the equivalent of parts per million (ppm), a unit that is deprecated by ISO.</p>		

Table A.117 (continued)

Data	Description	Unit or code list
H ₂ S concentration	Representative daily concentration of H ₂ S	Mole percent or grams per metric tonne ^a
CO ₂ concentration	Representative daily concentration of CO ₂	Mole percent or grams per metric tonne ^a
Remarks	Other information considered relevant	—
^a Grams per metric tonne is the equivalent of parts per million (ppm), a unit that is deprecated by ISO.		

A.2.7.9 Failure and maintenance data

The permanently installed well-completion equipment is normally run to failure. Preventive replacement may be performed for some string items, such as wireline-retrievable, surface-controlled subsurface safety valves (SCSSV).

In rare cases, items may be repaired downhole. This typically can be the case with casing- or tubing-retrievable, surface-controlled subsurface safety valves (SCSSV).

If a downhole repair action actually succeeds in restoring the function of an item, this can be reported by identifying the failure record for the item that initially failed. Depending on item category, the item-failure record can be assessed as described in [Table 8](#). The downhole repair action is reported by changing the remedial action code and giving the remedial action date. Should a failure occur on the same item at a later stage, a new failure record should be entered as described previously.

Information on downhole testing of valves should be collected, as this provides valuable information concerning interpretation of downhole failure trends.

A.2.8 Drilling

A.2.8.1 Top drives

Table A.118 — Type classification — Top drives

Equipment class — Level 6		Equipment type	
Description	Code	Description	Code
Top drives	TD	Hydraulically driven	HD
		Electrically driven	ED

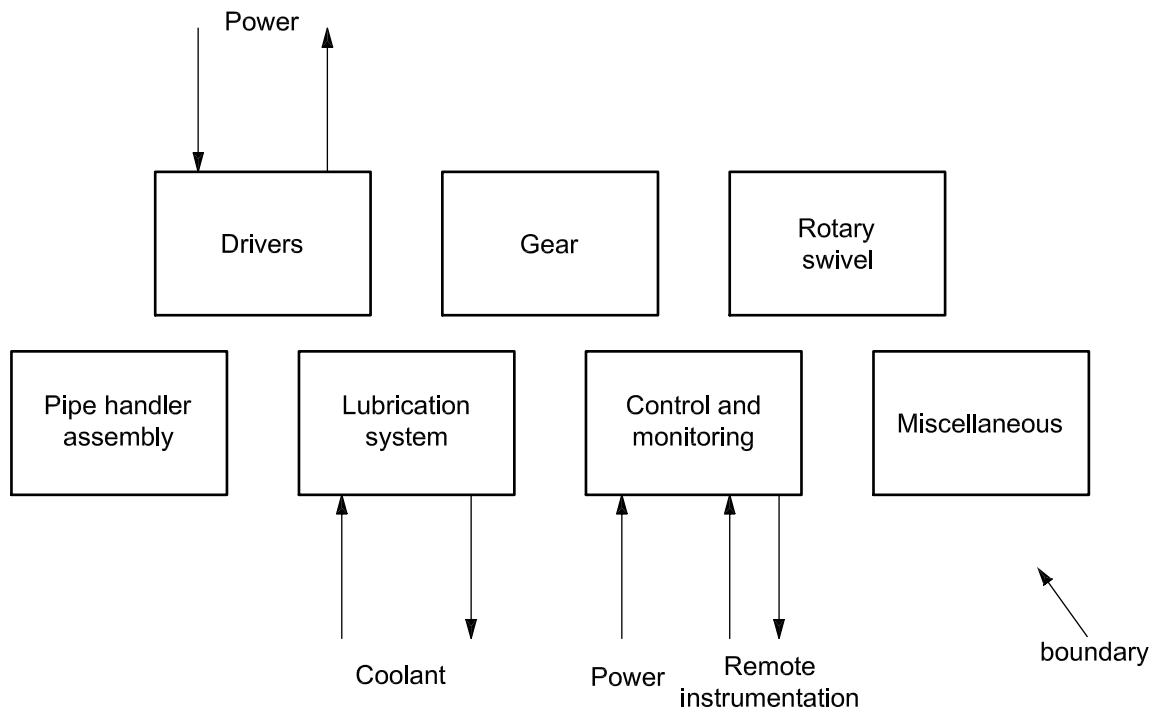

Figure A.39 — Boundary definition — Top drives

A top drive (frequently also referred to as a power swivel) is a piece of equipment that serves the following functions:

- rotating the drill string (formerly undertaken by the rotary table);
- providing a conduit for drilling mud (formerly undertaken by the rotary swivel);
- disconnecting/connecting pipe (formerly undertaken by the iron roughneck);
- closing in the drill pipe by an integrated kelly valve (formerly undertaken by the kelly valve in connection with the rotary table);
- lifting/lowering drill string by use of standard elevator (formerly undertaken by the hook by using same kind of elevator).

Top drives may be either electrically or hydraulically driven. If they are hydraulically driven, several hydraulic motors are normally used.

Elevator links and elevators are not regarded as a part of the top drive (standard drilling equipment).

Table A.119 — Equipment subdivision — Top drives

Equipment unit	Top drives						
Subunit	Drivers	Gear	Rotary swivel	Pipe-handler assembly	Lubrication	Control and monitoring	Miscellaneous
Maintainable items	Electric driver Hydraulic driver Radial, thrust and axial bearing	Bearings Packing/seals Coupling to driver Coupling to swivel Pinions Gearwheels	Gooseneck Packing/seals Axial, radial and thrust bearing Swivel housing Swivel stem	Link hanger incl. tilt actuators Pipe-handler position motor Swivel coupling Torque wrench	Oil tank Heaters Coolers Pump with motor Valves Filters Lube oil	Control panel Control Electric and/or hydraulic solenoid cabinet Service loops Manifolds Junction box Sensor Solenoid valves Check valves Other valves	Guide dolly frame Internal blow-out preventers (kelly valves) Counter-balance compensator/read-saver system

Table A.120 — Equipment-specific data — Top drives

Name	Description	Unit or code list	Priority
Type of driver	Specify type	Electric, hydraulic	High
Number of drives (applicable for hydraulic drives only)	Specify number	Number	High
Hydraulic power requirements (applicable for hydraulic drives only)	Pressure	Pascal (bar)	High
	Flow rate	Litres per minute	
Motor category (applicable for electric drives only)	Specify type	Induction, synchronous	High
Electrical supply requirements (applicable for electric drives only)	Voltage	Volt	High
	Current	Ampere	
Rated power	Max. output	Kilowatt	High
Normal operating power	Power	Kilowatt	High
Speed	Max. speed	Revolutions per minute	High
	Normal speed	Revolutions per minute	
Torque	Max. torque	Newton·metre	High
	At normal speed	Newton·metre	
	At max. speed	Newton·metre	
Pressure utilities	Hydraulic pressure	Pascal (bar)	Low
	Air pressure	Pascal (bar)	
Flow utilities	Hydraulic flow	Litres per minute	Low
	Air flow	Litres per minute	

Table A.120 (continued)

Name	Description	Unit or code list	Priority
Retractable dolly frame	Specify	Yes/no	Low
Mud pressure capacity	Pressure	Pascal (bar)	Low
Inside BOP design pressure	Pressure	Pascal (bar)	Low
Torque wrench capacity	Diameter	Millimetres	Low
	Torque	Newton·metre	
Elevator link hanger capacity	Capacity	Kilogram	High

A.2.8.2 Subsea blowout preventers (BOP)

There are two main types of blowout preventers used for drilling operations:

- subsea BOPs are used for drilling from a floating unit; this BOP is fixed to the seafloor wellhead;
- surface BOPs are used for land operations or for structures that are fixed to the seafloor.

In principle, a surface BOP is similar to a subsea BOP, and is described separately in A.2.8.3. The main differences are related to the control of the BOP functions and that the surface BOP, in general, has fewer functions than the subsea BOP. In addition, a subsea BOP has a flexible joint at the top to allow variation in the riser angle.

In addition a subsea BOP has a flexible joint at the top, connecting to the drilling riser (or completion riser), allowing variation in the riser angle

In normal drilling operations, the drilling-fluid pressure is higher than the reservoir pressure. This prevents an uncontrolled influx of formation fluids to the well bore.

The reservoir pressure can, from time to time for various reasons, exceed the drilling-fluid pressure. This results in an uncontrolled influx of formation fluids to the well bore. The main function of the BOP is, then, to close in the wellbore in order to circulate drilling fluid with a higher density to regain the hydrostatic control of the well.

The BOP can also be used for other purposes, such as testing casing, testing leak-off pressure, squeeze cement, etc.

The example of Subsea BOP taxonomy given in [Figure A.40](#) relates to subsea-mounted BOPs used for drilling.

Table A.121 — Type classification — Subsea blowout preventers (BOP)

Equipment class — Level 6		Equipment type	
Description	Code	Description	Code
Subsea blowout preventers	BO	Piloted hydraulic	PH
		Multiplexed electro-hydraulic	MX

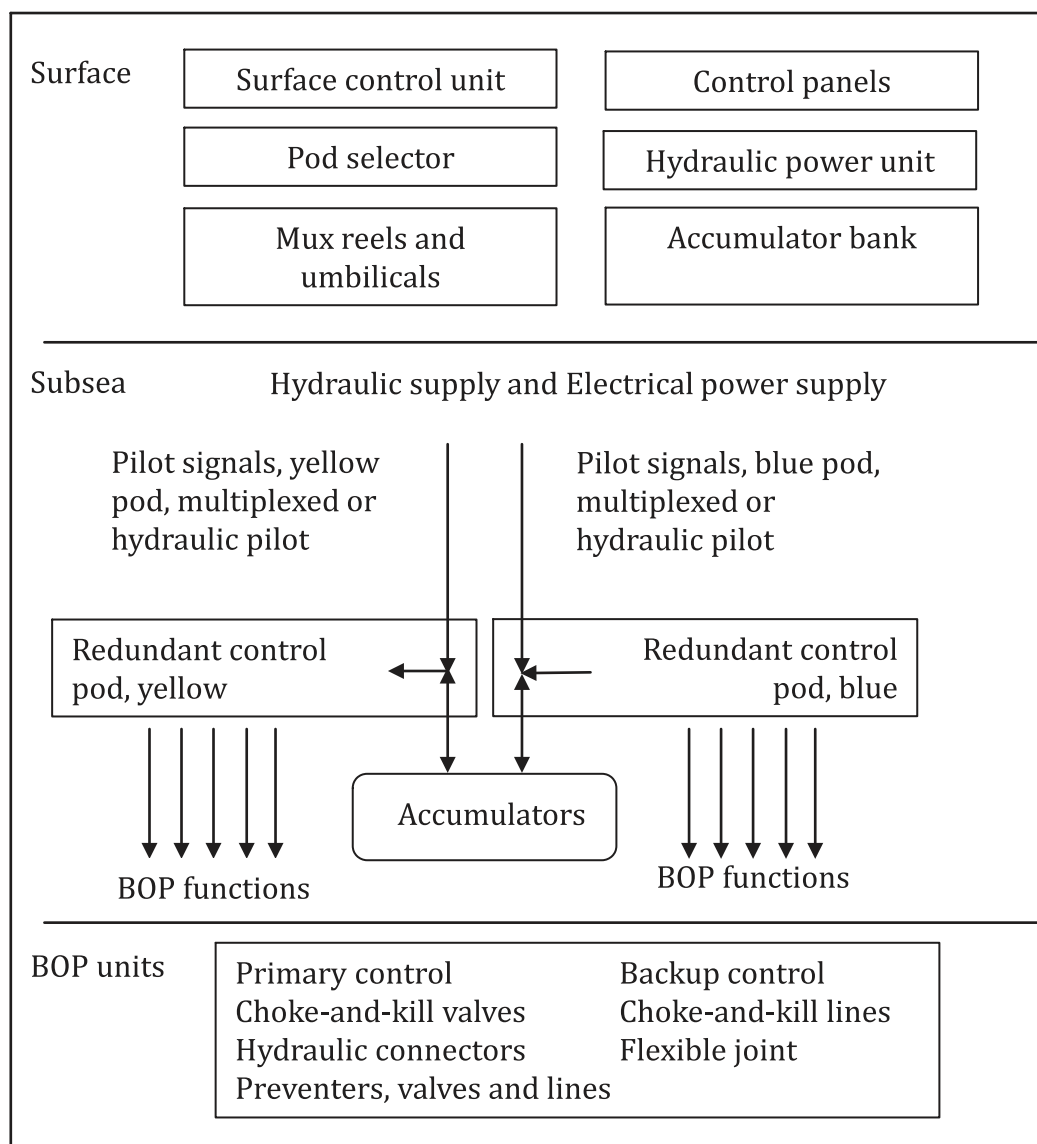

Figure A.40 — Boundary definition — Subsea blowout preventers (BOP)

A subsea BOP typically consists of the following main components (also table on equipment subdivision below):

- one or two annular preventers that seal around any tubular in the well;
- three to six ram preventers that, depending on dressing, can seal around various pipes in the well, shear pipe and seal an empty hole;
- Two (2) connectors, one connecting the BOP to the wellhead, called the wellhead connector, and the LMRP connector connecting the LMRP to the BOP and making it possible to disconnect the LMRP from the BOP;
- four to ten choke-and-kill valves that can be operated in order that the contained pressure in the BOP can be observed, pressurized fluid circulated out of the well and pressurized fluid pumped in the well.

Table A.122 — Equipment subdivision — Subsea blowout preventers (BOP)

Equipment unit	Subsea blowout preventers (BOP)				
Subunit	Preventers, valves and lines	Hydraulic connectors	Flexible joint	Primary control	Backup control ^b
Maintainable items	Annular preventers: Body Flanges Packing element Hydraulic piston Seals Ram preventers: Body Locking device Flanges Ram block Ram seals Shear blade Piston/operator Seals Choke-and-kill valves: Actuator Gate body Seals bonnet Choke-and-kill lines: Riser-attached line Couplers/ Connectors Seals Hose/Pipe Rigid pipe Gooseneck hose	LMRP connectors and wellhead connectors: Body Locking mechanism Piston(s) Main-bore seal ring Seals	Flexible joint: Flexible element Housing Flanges Wear ring Anodes Bolting	Subsea: Control Pod Pilot valves Shuttle valves Accumulators Pressure regulator valves Solenoid valves Check valves Other valves Hydraulic control fluid Seals El-equipment/SEM Instrumentation (e.g. flow/pressure sensors) Piping/Hoses Hydraulic bundles (pilot lines and main supply) Multiplex cables Rigid hydraulic supply line Surface: Control panels Surface control unit Electrical power supply Power supply Battery backup (UPS) Push button Instrumentation (e.g. pressure) sensor, readout) Hydraulic power unit Control Pod Pod reels Pod selector valve	Subsea: Solenoid valves Pilot valves Shuttle valves Accumulators Subsea control unit Battery Transducers Surface: Surface control unit Transducers ROV operated ^a: Hot stab Shuttle valves Valves, ROV operated shut-off ROV intervention panel
^a See API/Std 53 with respect to ROV backup. ^b Autoshear, Deadman system, ROV and acoustic control system is covered in this subunit, depending on the subsea BOP design.					

Table A.123 — Equipment-specific data — Subsea blowout preventers (BOP)

Name	Description	Unit or code list	Priority
Rig type	Specify	Semi-submersible, Drill ship, Jack-up, etc.	Medium
Rig mooring	Specify	DP, Anchored	Medium
BOP manufacturer/supplier	Specify	Free text	High

Table A.123 (continued)

Name	Description	Unit or code list	Priority
Dimension	Specify (inner diameter)	Millimetres (inches)	Medium
Size	Height and mass	Millimetres (inches), kilograms (tons)	Low
Pressure rating	Specify	Pascal (pounds per square inch)	High
Installed location/ recorded water depth	Specify	Foot (metres)	Medium
Ram preventers – manufacturer (and model)	Specify	Specify	High
Ram preventers, pressure rating	Specify	Pascal (pounds per square inch)	High
Number of fixed pipe rams	Specify	Number	Medium
Number of flexible pipe rams	Specify	Number	Medium
Number of blind rams	Specify	Number	Medium
Number of blind shear rams	Specify	Number	Medium
Number of casing shear rams	Specify	Number	Medium
Annular preventers – manufacturer (and model)	Specify	Specify	High
Annular preventers, pressure rating	Specify	Pascal (pounds per square inch)	High
Number of annular preventers	Specify	Number	Medium
LMRP connector – manufacturer and model	Specify	Specify	High
LMRP connector pressure rating	Specify	Pascal (pounds per square inch)	Medium
Wellhead connector – manufacturer (and model)	Specify	Specify	High
Wellhead connector pressure rating	Specify	Pascal (pounds per square inch)	Medium
Number of wellhead connections	Specify total number of times the BOP has been run and (re-) latched to the wellhead during surveillance period	Number	Medium
Choke-and-kill valve – manufacturer (and model)	Specify	Specify	Medium
Number of choke-and-kill valves	Specify	Number	Medium
Type of control fluid	Specify	Oil-based, water-based	High
Type of control system	Specify	Multiplexed, pilot hydraulic, other	High
Make and version of control system	Specify	Specify	High
Secondary control system	Specify	Specify	Medium

A.2.8.3 Surface blowout preventers (BOP)

The equipment class “Surface blowout preventers (BOP)” are specific for land operations or for structures that are fixed to the seafloor, and are too a large extent similar to the subsea BOP equipment subsea. Hence parts of the example shown for subsea blowout preventers is also applicable to surface blowout preventers, except for specific subsea maintainable items listed in A.2.8.2.

In principle, a surface BOP is similar to a subsea BOP. The main differences are related to the control of the BOP functions and that the surface BOP, in general, has fewer functions than the subsea BOP.

The main function of the Surface BOP is to close in the wellbore in order to circulate drilling fluid with a higher density to regain the hydrostatic control of the well. The Surface BOP can also be used for other purposes, such as testing casing, testing leak-off pressure, squeeze cement, etc.

The example of Surface BOP taxonomy given in [Figure A.41](#) relates to surface-mounted BOPs used for drilling.

Table A.124 — Type classification — Surface blowout preventers (BOP)

Equipment class — Level 6		Equipment type	
Description	Code	Description	Code
Surface blowout preventers	BT	Piloted hydraulic	PH
		Multiplexed electro-hydraulic	MX

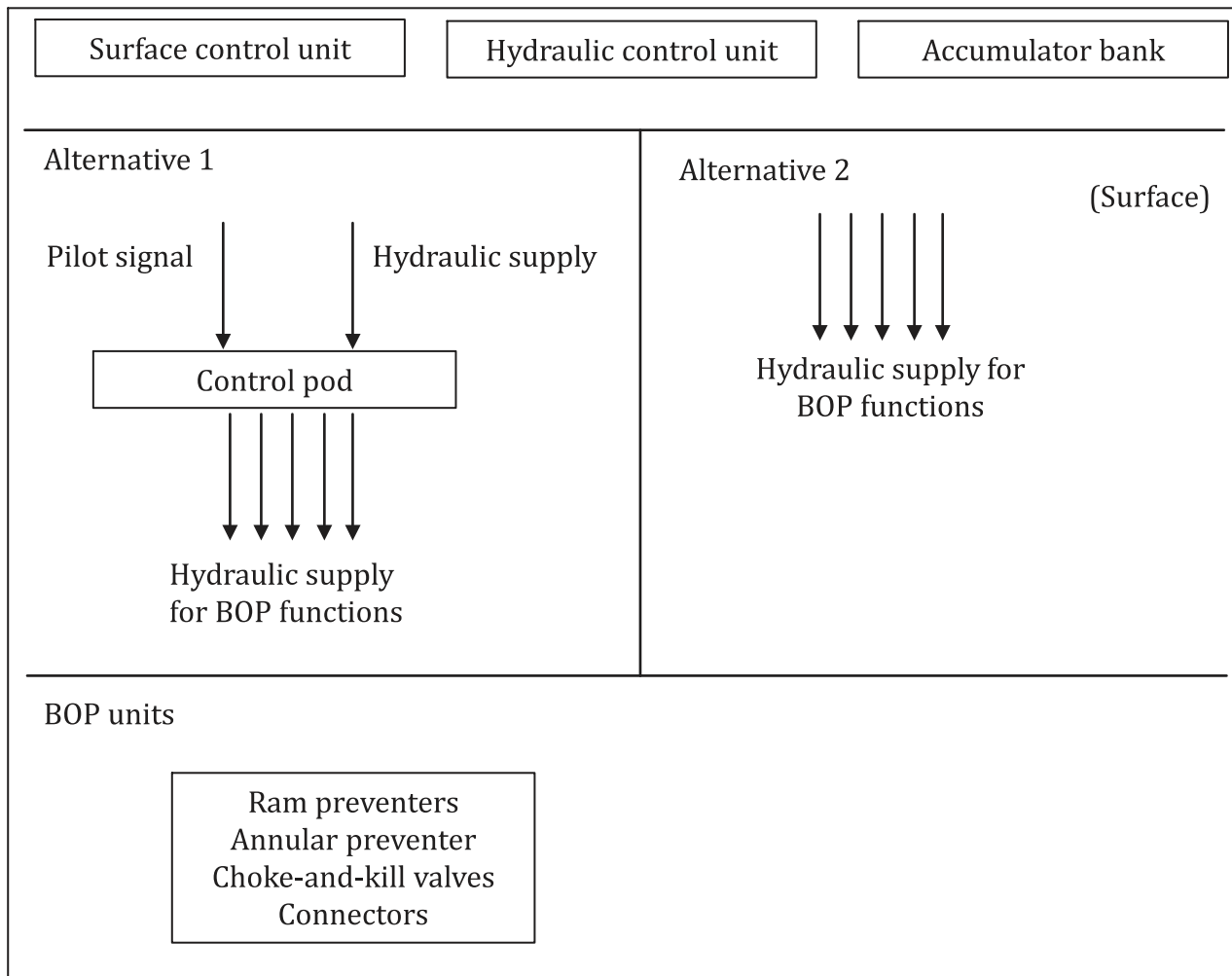

Figure A.41 — Boundary definition — Surface blowout preventers (BOP)

A Surface BOP typically consists of the following main components (also table on equipment subdivision below):

- a) one or two annular preventers that seal around any tubular in the well;
- b) three to six ram preventers that, depending on dressing, can seal around various pipes in the well, shear pipe and seal an empty hole;
- c) a main connector that connects the BOP to the wellhead;

- d) four to ten choke-and-kill valves that can be operated in order that the contained pressure in the BOP can be observed, pressurized fluid circulated out of the well and pressurized fluid pumped in the well.

Table A.125 — Equipment subdivision — Surface blowout preventers (BOP)

Equipment unit	Surface blowout preventers (BOP)		
Subunit	Preventers, valves and lines	Connectors	Primary control
Maintainable items	Annular preventer: Body Flanges Packing element Hydraulic piston Seals Ram preventers: Body Locking device Flanges Ram block bonnet Ram seals Shear blade Piston/operator Seals Choke-and-kill valves: Actuator Gate body Seals bonnet Gooseneck hose Choke-and-kill lines: Connectors Seals Hose/Pipe Rigid pipe	Connectors: Body Locking mechanism Piston(s) Main-bore seal ring Seals	Surface controls: Control Pod Pilot valves Pressure regulator valves Solenoid valves Check valves Other valves Hydraulic control fluid Seals EI-equipment/SEM Instrumentation (e.g. flow/pressure sensors) Piping/Hoses Hydraulic bundles (pilot lines and main supply) Multiplex cables Hydraulic supply line Control panels Surface control unit Electrical power supply Power supply Battery backup (UPS) Push button Instrumentation (e.g. pressure sensor, readout) Hydraulic power unit

Table A.126 — Equipment-specific data — Surface blowout preventers (BOP)

Name	Description	Unit or code list	Priority
Installation type	Specify	Semi-submersible, jack-up, TLP, onshore, other	Medium
Mooring	Specify	DP, anchored, no	Medium
BOP manufacturer/supplier	Specify	Free text	High
Dimension	Specify (inner diameter)	Millimetres (inches)	Medium
Size	Height and mass	Millimetres (inches), kilograms (tons)	Low
Pressure rating	Specify	Pascal (pounds per square inch)	High
Installed location/ recorded water depth	Specify	Foot (metres)	Medium

Table A.126 (continued)

Name	Description	Unit or code list	Priority
Ram preventers – manufacturer (and model)	Specify	Specify	High
Ram preventers, pressure rating	Specify	Pascal (pounds per square inch)	High
Number of ram preventers	Specify	Number	Medium
Annular preventers – manufacturer (and model)	Specify	Specify	High
Annular preventers, pressure rating	Specify	Pascal (pounds per square inch)	High
Number of annular preventers	Specify	Number	Medium
Wellhead connector – manufacturer (and model)	Specify	Specify	High
Wellhead connector pressure rating	Specify	Pascal (pounds per square inch)	Medium
Number of wellhead connections	Specify total number of times the BOP has been run and (re-) latched to the wellhead during surveillance period	Number	Medium
Choke-and-kill valve – manufacturer (and model)	Specify	Specify	Medium
Number of choke-and-kill valves	Specify	Number	Medium
Type of control fluid	Specify	Oil-based, water-based	High
Type of control system	Specify	Multiplexed, pilot hydraulic, other	High
Make and version of control system	Specify	Specify	High
Secondary control system	Specify	Specify	Medium

A.2.9 Well intervention

A.2.9.1 Surface well control equipment

Surface well control equipment is relevant for the following well interventions:

- coiled tubing;
- wireline;
- snubbing.

The principles for data collection and exchange defined in this International Standard can also be applied for such equipment.

Note that the Surface well control equipment is all topsides or onshore located equipment. In case subsea well intervention takes place (where e.g. surface tree is covered in [Table A.128](#)), there will be interfaces on top of this surface tree, and this equipment class in this section provides further details.

Note that subsea and surface BOPs are listed in A.2.8.2 and A.2.8.3.

The following three equipment classes are mentioned separately in [Table A.4](#), but due to similarities they are combined in this section, and equipment type classification in the table below should therefore be used in reliability data collection for such surface well control equipment:

- coiled tubing, surface well control equipment;
- wireline, surface well control equipment;
- snubbing, surface well control equipment.

Table A.127 — Type classification - Surface well control equipment (for well intervention)

Equipment class — Level 6		Equipment type	
Description	Code	Description	Code
Surface well control equipment (for well intervention)	WC	Coiled tubing	W1
		Snubbing	W2
		Wireline	W3

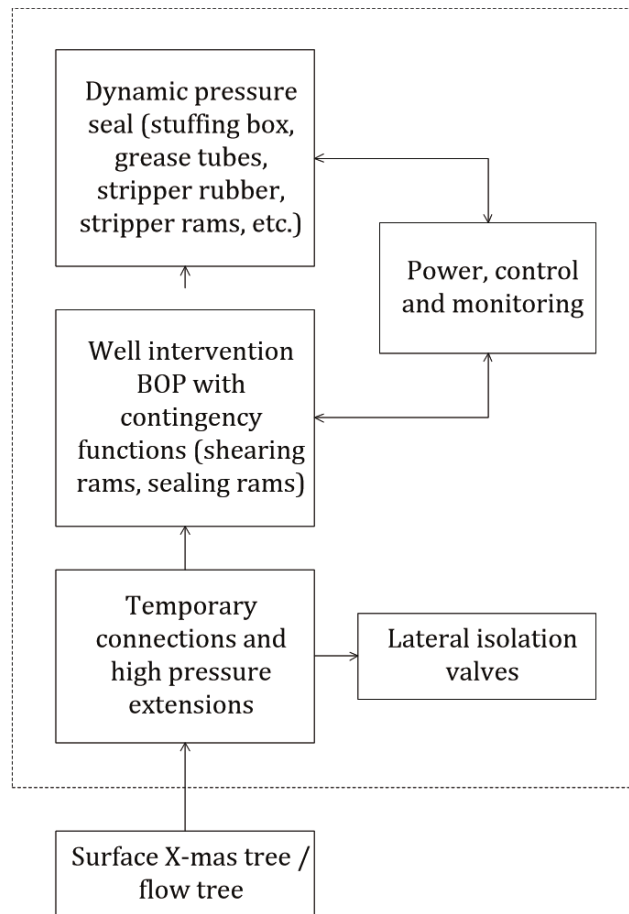

Figure A.42 — Boundary definition - Surface well control equipment (for well intervention)

Table A.128 — Equipment subdivision - Surface well control equipment (for well intervention)

Equipment unit	Surface well control equipment (for well intervention)				
Subunit	Temporary connection and high pressure extension	Well Intervention BOP	Dynamic pressure seal	Lateral isolation valve	Control and monitoring
Maintainable items	Sealing surface Sealing element	Ram assembly Sealing element Shearing element	Sealing element Hydraulic circuit	Valve, process isolation Valve, utility isolation	Prime mover Solenoid control valve Pilot controlled valve Hand actuator Accumulator Electronics module Hydraulic coupling LV power/signal connector Relief valve Shuttle valve Filter Pump Hydraulic fluid tank

Table A.129 — Equipment-specific data — Surface well control equipment (for well intervention)

Name	Description	Unit or code list	Priority
Manufacturer	Specify	Text	High
Unit identification	Manufacturer model/part/serial number	Number or name	High
Unit function	Functional description of unit	Text	High
Unit type	Type of unit (ram, gate valve, ball valve, etc.)	Text	High
Size	Nominal size (bore)	Millimetres (inches)	High
Type of connections	Specify	Text	
Elastomer type	Specify elastomer type for equipment with dynamic and static sealing elements.	Text	High
Pressure rating	Working pressure rating	Pascal (bar, psi)	High
Pressure exposure	Operational pressures encountered	Pascal (bar, psi)	High
Fluid exposure	Main fluids only	Oil, gas, condensate, brine, CO ₂ , H ₂ S	High

A.2.9.2 Subsea well intervention

Reliability data collection for 'Subsea well intervention' may be performed on three modes of operation, which may have slightly different taxonomy formats. These are:

- a) riserless well intervention (RLWI);
- b) open water intervention;
- c) Thru-BOP/Drilling riser intervention.

RLWI for executing subsea wireline operations is comparable to the wireline operations done using surface well control equipment as described in A.2.9.1.

This International Standard presents equipment specific data for b) open water intervention, and this is thus assigned the equipment class OI, see below.

Other intervention tools appearing as part of this International Standard such as running tools for flow control module, SCM and valve retrievals on the subsea production facility are not covered in this taxonomy; see equipment class "Subsea intervention".

Table A.130 — Type classification — Subsea well intervention: Open water intervention

Equipment class — Level 6		Equipment type	
Description	Code	Description	Code
Open water intervention	OI	Well completion	WC
		Well intervention - open sea (tree mode)	WI
		Full workover (tree mode)	WO

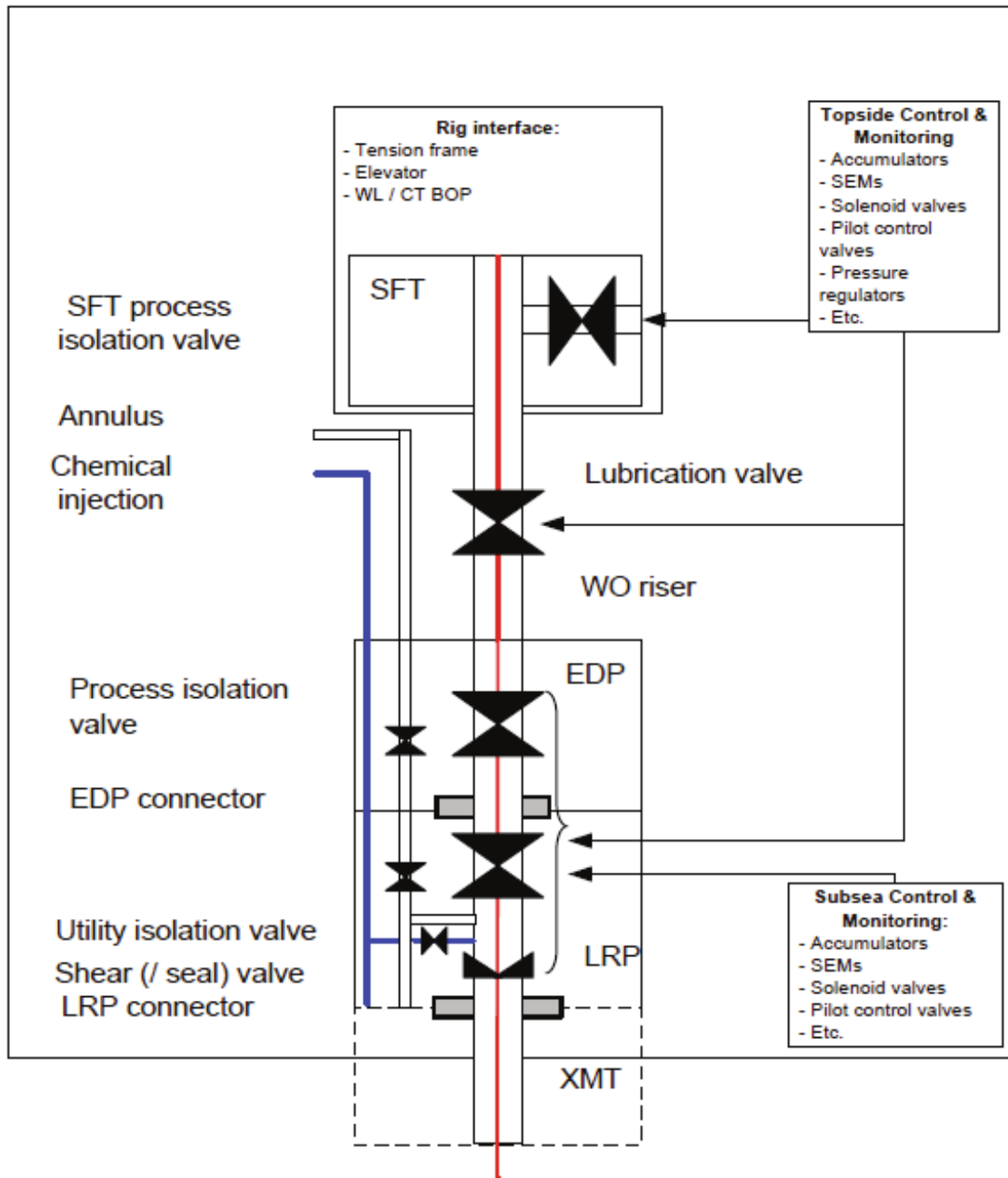

Figure A.43 — Boundary definition — Subsea well intervention: Open water intervention

Please note the following remarks regarding figure above:

- 1) Dotted lines indicate equipment not included. In addition, note that only some part of the rig interface is included in this equipment class (see [Table A.131](#)), whilst other parts are covered in equipment class Surface well control equipment (A.2.9.1).
- 2) The figure is for illustration only, and does not cover all components listed in the equipment subdivision table.
- 3) Normally the Process Isolation valve is below the EDP connector and the main bore valve above the EDP connector is called Retainer Valve.
- 4) Several types of control system configurations are available on the market, e.g. direct hydraulic, electro hydraulic.

- 5) EDP/WCP Process isolation valves could for instance be PIV, RV or XOV. Note that process isolation valves may require to cut.
- 6) Shear (/seal) valve is typically a shear (seal) ram.
- 7) Heave elimination is usually performed through elevator and top drive motion compensator or heave compensated crane. Slick joint position and function shall be clarified.
- 8) Note that [Table A.4](#) has “Drilling and completion riser” as an equipment class that would cover the workover riser.
- 9) The Workover Control System (WOCS) is different and should therefore be analysed separately. This is done by the introduction of two new subunits, ‘Topside control & monitoring’ and ‘Subsea control & monitoring’, which are always associated with the well intervention taxonomies and should not be confused with the “Subsea production control” equipment class.
- 10) Safety joint (equipment class Subsea pipelines) and Stress joint (equipment class Dry tree risers) can be different from WO safety / stress joints

Table A.131 — Equipment subdivision — Subsea well intervention: Open water intervention

Equipment unit	Subsea well intervention: Open water intervention					
Subunit	Well control package (WCP)	Emergency disconnect package (at the top of WCP)	WO riser	Rig interface ^a	Topside control & monitoring ^b	Subsea control and monitoring ^b
Maintainable items	Valve, process isolation Valve, utility isolation Valve, shear Connector	Retainer valve Valve, utility isolation Connector Bleed-off valve	WO stress joint WO safety joint Tension joint Heave eliminator Slick joint Swivel	Tension frame Elevator interface	Solenoid control valve Pilot control valve Accumulator – topside Hydraulic coupling Master control station (topside) Pressure regulator WOCS Pump incl. driver LV power/ signal connector Shutdown panel Filter Reels Purge system UPS Valve, relief	Solenoid control valve Pilot control valve Accumulator – subsea Hydraulic coupling WO Umbilical Subsea electronic module LV power/ signal connector Filter Valve, relief Valve, shuttle Subsea powered pump Hydraulic fluid subsea tanks

^a See also equipment class Surface well control equipment in A.2.9.1.

^b WOCS takes temporary control (from normal Subsea production control – see A.2.6.1) of subsea X-mas tree during subsea intervention. WOCS takes over permanent control of SPS (e.g. for subsea X-mas trees).

Table A.132 — Equipment-specific data — Subsea well intervention: Open water intervention

Name	Description	Unit or code list	Priority
Rig type	Specify	Semi-submersible, drill ship, etc.	Medium
Control system ^a	Intervention control system	Direct hydraulic Direct electro hydraulic Multiplexed electro hydraulic	Medium

^a This is a subset and equivalent to equipment type classification in [Table A.87](#) for Subsea production control

A.2.10 Marine

A.2.10.1 Jacking and fixation

Jack-up units used in the oil and gas industry can be divided into two main groups, drilling jack-ups and service jack-ups.

Drilling jack-ups are mainly used for:

- exploration drilling;
- production drilling, completion and well intervention on subsea template;
- production drilling, completion and well intervention on wellhead platform.

Service jack-ups are mainly used for:

- accommodation;
- heavy lift;
- geotechnical surveys.

Table A.133 — Type classification — Jacking and fixation

Equipment class - Level 6		Equipment type	
Description	Code	Description	Code
Jacking and fixation	JF	Open-truss legs	TL
		Columnar legs	CL

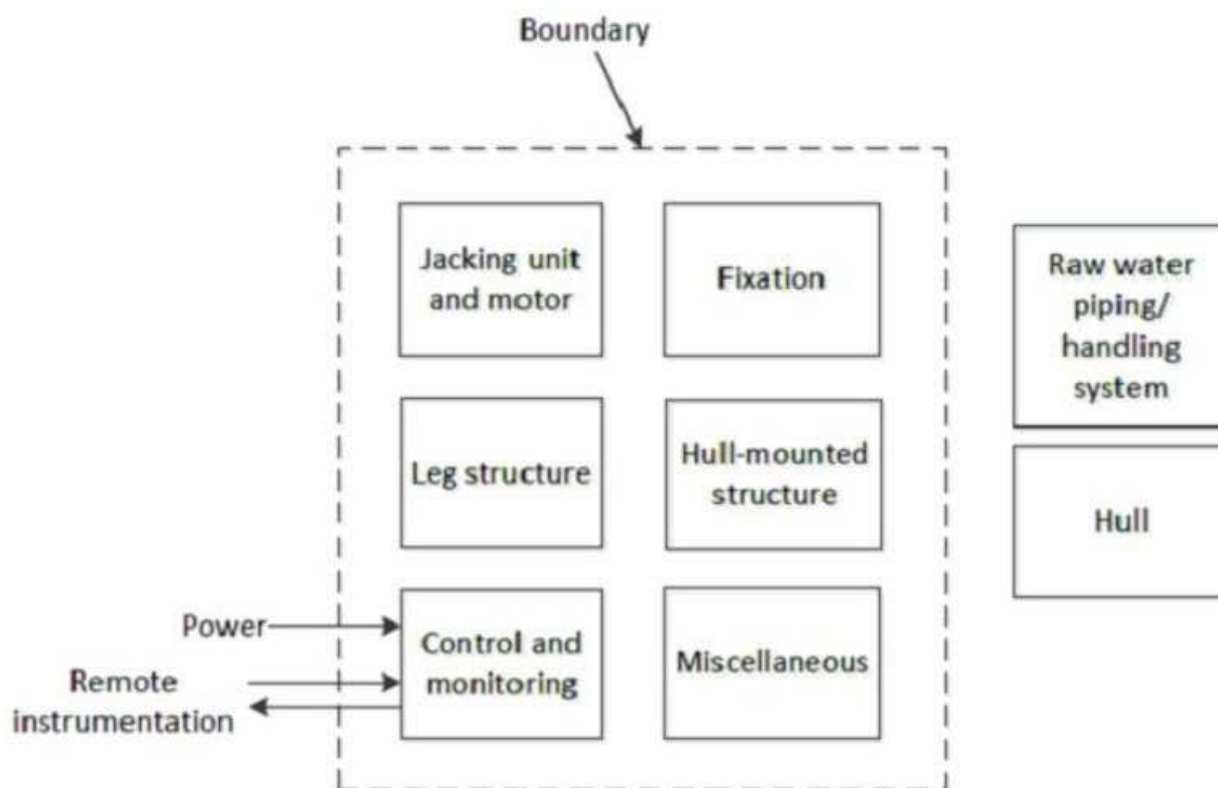

Figure A.44 — Boundary definition — Jacking and fixation

Table A.134 — Equipment subdivision — Jacking and fixation

Equipment unit	Jacking and fixation					
Subunit	Jacking unit	Fixation	Leg structure	Hull-mounted structure	Control and monitoring	Miscellaneous
Maintainable items	Load shift system Motor Gear Box Pinion Variable frequency drive Brake Greasing system	Clamping unit	Chord Bracing Spud can Rack Jetting system Corrosion protection Greasing system	Jacking support structure Leg guides	Actuating device Control unit Internal power supply Monitoring Sensor Valve Wiring Piping Seals	HPU Others

Table A.135 — Equipment-specific data — Jacking and fixation

Name	Description	Unit or code list	Priority
Application	Classify	Exploration drilling Production drilling/completion on subsea template Well intervention on subsea template Production drilling/completion on wellhead platform Well intervention on wellhead platform Service jack-up for Accommodation Service jack-up for Heavy lift Service jack-up for Geotechnical surveys	High
Holding capacity survival	Survival holding capacity	Tonnes	Medium
Jacking load emergency	Emergency jacking load	Tonnes	Low
Jacking load rated	Rated jacking load	Tonnes	Medium
Output torque	Gear box output torque	N/m	Medium
Pinions count	Number of pinions	Each	Medium
Power operating	Power – operating	Kilowatts, KW	Medium
Speed hoist - max load	Hoist speed at max load	Metres per second, m/s	Medium
Speed hoist – no load	Hoist speed at no load	Metres per second, m/s	Low
Speed input shaft	Speed_input_shaft	Revolutions per minute ,rpm	Low
Speed output shaft	Speed_output_shaft	Revolutions per minute ,rpm	Low
Torque brake	Brake torque	N/m	Low
Jacking frame type	Jacking frame type	Fixed, floating	Medium

A.2.11 Utilities

No examples are included in [Annex A](#).

NOTE Utilities can include anything from single equipment units (e.g. pumps) to more complex assemblies (packages).

EXAMPLES Fire water system, HVAC, hydraulic power supply, etc.

Depending on the application, data can be collected on single-unit level and the reliability estimated by calculating the total reliability for the utility assembly. Alternatively, data can be collected for the complete utility system as a whole. It is necessary to establish the taxonomic definition defined or adapted to the selected alternative.

A.2.12 Auxiliaries

No examples are included in [Annex A](#).

Annex B (normative)

Interpretation and notation of failure and maintenance parameters

B.1 Failure interpretation

When planning to collect data (see 7.1.2 and B.2.6), be aware that a failure can occur in one of a number of failure modes, e.g. complete loss of function, function degradation below an acceptable limit or an imperfection in the state or condition of an item (incipient failure) that is likely to result in a functional failure if not corrected.

Also be aware that it can be useful to make a distinction between the collection of data for reliability purposes and for availability purposes as follows:

- a) For reliability purposes, it is mainly the intrinsic failures of the equipment unit that are of interest, i.e. physical failures that occur on the equipment being considered and that normally require some restoration (corrective maintenance) that it is necessary to record.
- b) For the full lifetime story of equipment, it is necessary to record all actual preventive maintenance actions in a way similar to that for the corrective maintenance.
- c) For availability purposes, all failures that have caused some equipment outage should be recorded. This can include stoppages due to operational limits being exceeded (e.g. real trips) where no physical failure of the equipment occurred.
- d) Even if no failures are experienced within the surveillance time, it is possible to estimate the failure rate by properly censored data (see C.3.3). Hence, recording the reliability history may also be useful for equipment in periods with no failures.

[Table B.1](#) gives some guidance on this issue by distinguishing between data collected as reliability data and additional data collected as availability data.

Annex F, and ISO/TR 12489:2013 and IEC 61508:2010 also give guidance on what to consider as a failure for safety equipment. Such definition can be related to functional loss, reduced capacity or operation outside prescribed limits.

The full description of a failure might not be possible before a corrective action is carried out. In some cases (incipient failures), the corrective action may deliberately be deferred (e.g. opportunity maintenance). In this case, it can be necessary to record both the date of failure detection and the date of the corrective action. For analysis purposes, the latter date should normally be used.

Table B.1 — Failure in relation to reliability and availability

Type of failure/maintenance to record	Reliability	Availability
Failures that require some corrective maintenance action to be carried out (repair, replacement)	Yes	Yes
Failure discovered during inspection, testing and/or preventive maintenance that requires repair or replacement of typically non-wear items (seals, bearings, impellers, etc.)	Yes	Yes
Failure of safety devices or control/monitoring devices that necessitates shutdown (trip) or reduction of the items capability below specified limits	Yes	Yes
Shutdown (trip) of the item (whether automatically or manually controlled) due to external conditions or operating errors, where no physical failure condition of the item is revealed	No	Yes
Failure of the equipment caused by external impact (e.g. lack of power supply, structural impact, etc.)	No	Yes
Periodic replacement of consumables and normal wear parts	No	No
Minor planned maintenance services, such as adjustments, lubrication, cleaning, oil replacement, filter replacement or cleaning, painting, etc.	No	Yes
Testing and inspections	No	Yes
“On-demand” activations	Yes	Yes
Preventive or planned maintenance ^a	Yes (No)	Yes
Modifications, new work, upgrades ^b	No	Yes/No
^a To get the full lifetime history of the equipment, the actual preventive maintenance should be recorded. For recording failures only, this can be skipped.		
^b Modifications are normally not a part of maintenance but are frequently done by maintenance personnel.		

B.2 Failure and maintenance data notations

B.2.1 General

In order to limit database size and make it easier to analyse the data, it is recommended that coded information be used wherever applicable. A drawback with codes is that potentially useful information can be lost and that selecting inappropriate codes can lead to non-informative information. The availability of too many codes can be confusing and the codes can overlap, while too few codes might not sufficiently describe the area one is aiming to cover. A unified definition and interpretation of codes is necessary for obtaining highly reliable information.

In all cases, it is recommended to supplement the coding with some additional free-text capability in order to improve interpretation of single events, both for quality purposes before the data are entered into the database and for subsequent detailed analysis of single records (e.g. failure events).

Annex B.2 presents a method of coding that has been found to be useful when collecting RM data within the petroleum and natural gas industry, and should be equally applicable for similar equipment classes in the petrochemical industry. For some specific equipment and/or specific uses, supplementary codes may be used.

Establish a method of reporting failure (see 7.1.2) that records the time and date of failure together with details of the failure mode (see B.2.6), the failure mechanism (see B.2.2) and the failure cause (root cause) (see B.2.3). Also, record the detection method (see B.2.4) and the maintenance activity (see B.2.5). Use the codes given in the tables wherever practicable and additional free text where necessary.

Take care to distinguish between failure mechanism and failure mode.

Failure modes are presented in [Tables B.6 to B.14](#) for those equipment examples included in [Annex A](#) as shown in [Table A.4](#). [Table B.15](#) summarises all the failure modes.

Subdivision codes for failure mechanisms and failure causes, e.g. numbers 1.1, 1.2, etc., should be preferred before the general category failure code, e.g. 1, and so on (see [Tables B.2.](#) and B.3).

How failure mode, failure mechanism and failure cause are related to different taxonomy levels is shown in [Table 3.](#)

B.2.2 Failure mechanism

The failure mechanism is the physical, chemical or other process or combination of processes that leads to the failure. It is an attribute of the failure event that can be deduced technically, e.g. the apparent, observed cause of the failure. The failure mechanism's root cause(s) is/are coded whenever this information is available. (A separate field for this is recommended in this International Standard.)

The codes on failure mechanism are basically related to one of the following major categories of failure types:

- a) mechanical failures;
- b) material failures;
- c) instrumentation failures;
- d) electrical failures;
- e) external influence;
- f) miscellaneous.

This categorization is rather coarse and within each category a more detailed categorization is recommended as shown in [Table B.2.](#) If there is not sufficient information to apply codes at this sublevel, then codes on the main level as listed above may be used. This implies that descriptive codes for mechanical failures, numbered 1.1, 1.2, etc., should be preferred to the general category failure code, 1.0, and so on (see [Table B.2.](#)).

The failure mechanism should normally be related to a lower indenture level (subunit or maintainable-item level). In practical terms, the failure mechanism represents a failure mode at maintainable item level.

Care should be taken to distinguish between failure mechanism and failure mode.

EXAMPLE It is recorded that a valve started leaking hydrocarbons to the environment but no further causes are recorded. Here, the failure mode should be coded ELP (external leak of process medium) and the failure mechanism coded unknown (6.4), not leakage (1.1).

Failure mechanism is also related to the failure cause (see B.2.3); the latter aimed at revealing the underlying root cause of the failure.

Six categories of failure mechanism are identified in [Table B.2.](#), together with subdivisions and related codes to be used in data bases.

Table B.2 — Failure mechanism

Failure mechanism		Subdivision of the failure mechanism		Description of the failure mechanism
Code number	Notation	Code number	Notation	
1	Mechanical failure	1.0	General	A failure related to some mechanical defect but where no further details are known
		1.1	Leakage	External and internal leakage, either liquids or gases: If the failure mode at equipment unit level is coded as “leakage”, a more causally oriented failure mechanism should be used wherever possible.
		1.2	Vibration	Abnormal vibration: If the failure mode at equipment level is “vibration”, which is a more causally oriented failure mechanism, the failure cause (root cause) should be recorded wherever possible.
		1.3	C l e a r a n c e / alignment failure	Failure caused by faulty clearance or alignment
		1.4	Deformation	Distortion, bending, buckling, denting, yielding, shrinking, blistering, creeping, etc.
		1.5	Looseness	Disconnection, loose items
		1.6	Sticking	Sticking, seizure, jamming due to reasons other than deformation or clearance/alignment failures
2	Material failure	2.0	General	A failure related to a material defect but no further details known
		2.1	Cavitation	Relevant for equipment such as pumps and valves
		2.2	Corrosion	All types of corrosion, both wet (electrochemical) and dry (chemical)
		2.3	Erosion	Erosive wear
		2.4	Wear	Abrasive and adhesive wear, e.g. scoring, galling, scuffing, fretting
		2.5	Breakage	Fracture, breach, crack
		2.6	Fatigue	If the cause of breakage can be traced to fatigue, this code should be used.
		2.7	Overheating	Material damage due to overheating/burning
		2.8	Burst	Item burst, blown, exploded, imploded, etc.
3	Instrument failure	3.0	General	Failure related to instrumentation but no details known
		3.1	Control failure	No, or faulty, regulation
		3.2	N o s i g n a l / indication/alarm	No signal/indication/alarm when expected
		3.3	Faulty signal/ indication/alarm	Signal/indication/alarm is wrong in relation to actual process. Can be spurious, intermittent, oscillating, arbitrary
		3.4	Out of adjustment	Calibration error, parameter drift
		3.5	Software error	Faulty, or no, control/monitoring/operation due to software error
		3.6	C o m m o n c a u s e / Common mode failure	Several instrument items failed simultaneously, e.g. redundant fire and gas detectors; also failures related to a common cause.

^a The data acquirer should judge which is the most important failure mechanism descriptor if more than one exist, and try to avoid the 6.3 and 6.4 codes.

^b Human errors are not reflected in the failure mechanisms, but are considered as part of the failure causes.

Table B.2 (continued)

Failure mechanism		Subdivision of the failure mechanism		Description of the failure mechanism
Code number	Notation	Code number	Notation	
4	Electrical failure	4.0	General	Failures related to the supply and transmission of electrical power, but where no further details are known
		4.1	Short circuiting	Short circuit
		4.2	Open circuit	Disconnection, interruption, broken wire/cable
		4.3	No power/voltage	Missing or insufficient electrical power supply
		4.4	Faulty power/voltage	Faulty electrical power supply, e.g. overvoltage
		4.5	Earth/isolation fault	Earth fault, low electrical resistance
5	External influence	5.0	General	Failure caused by some external events or substances outside the boundary but no further details are known
		5.1	Blockage/plugged	Flow restricted/blocked due to fouling, contamination, icing, flow assurance (hydrates), etc.
		5.2	Contamination	Contaminated fluid/gas/surface, e.g. lubrication oil contaminated, gas-detector head contaminated
		5.3	Miscellaneous external influences	Foreign objects, impacts, environmental influence from neighbouring systems
6	Miscellaneous ^{a, b}	6.0	General	Failure mechanism that does not fall into one of the categories listed above
		6.1	No cause found	Failure investigated but cause not revealed or too uncertain
		6.2	Combined causes	Several causes: If there is one predominant cause this should be coded.
		6.3	Other	No code applicable: Use free text.
		6.4	Unknown	No information available
^a The data acquirer should judge which is the most important failure mechanism descriptor if more than one exist, and try to avoid the 6.3 and 6.4 codes. ^b Human errors are not reflected in the failure mechanisms, but are considered as part of the failure causes.				

B.2.3 Failure cause

B.2.3.1 General

The objective of these data is to identify the initiating event (“root causes”) in the sequence leading up to a failure of an equipment item. Five categories of failure cause are identified in [Table B.3](#) together with sub divisions and related codes to be used in databases.

The failure causes are classified in the following categories:

- 1) design-related causes;
- 2) fabrication/installation-related causes;
- 3) failures related to operation/maintenance;
- 4) failures related to management;
- 5) miscellaneous.

As for failure mechanism, the failure cause can be recorded at two levels depending on how much information is available. If the information is scarce, only a coarse classification, i.e. codes 1, 2, 3, 4 and

5, can be possible, while a more detailed subdivision code number can be recorded if more information is available.

Failure causes are commonly not known in depth when the failure is observed and, in order to reveal the root cause of a failure, a specific root cause analysis can be useful. This is in particular relevant for failures of a more complex nature and where the failure is important to avoid due to its consequences. Examples are failures with serious safety and/or environmental consequences, abnormally high failure rates compared to the average and failures with a high repair cost.

Due care is required so as not to confuse failure mechanism (describing the apparent, observed cause of failure) with failure cause (describing the underlying or “root” cause of a failure).

Table B.3 — Failure causes

Code number	Notation	Subdivision code number	Subdivision of the failure cause	Description of the failure cause
1	Design-related causes	1.0	General	Inadequate equipment design or configuration (shape, size, technology, configuration, operability, maintainability, etc.), but no further details known
		1.1	Improper capacity	Inadequate dimensioning/capacity
		1.2	Improper material	Improper material selection
2	Fabrication/installation-related causes	2.0	General	Failure related to fabrication or installation, but no further details known
		2.1	Fabrication failure	Manufacturing or processing failure
		2.2	Installation failure	Installation or assembly failure (assembly after maintenance not included)
3	Failure related to operation/maintenance	3.0	General	Failure related to operation/use or maintenance of the equipment but no further details known
		3.1	Off-design service	Off-design or unintended service conditions, e.g. compressor operation outside envelope, pressure above specification, etc.
		3.2	Operating error	Human error: Mistake, misuse, negligence, oversights, etc. during operation (e.g. due to human fatigue)
		3.3	Maintenance error	Human error: Mistake, misuse, negligence, oversights, etc. during maintenance (e.g. due to human fatigue)
		3.4	Expected wear and tear	Failure caused by wear and tear resulting from normal operation of the equipment unit
4	Failure related to management	4.0	General	Failure related to management issues, but no further details known
		4.1	Documentation error	Human error: Failure related to procedures, specifications, drawings, reporting, etc. (e.g. due to human fatigue)
		4.2	Management error	Failure related to planning, organization, quality assurance, etc.
<p>^a The data acquirer should judge which is the most important cause if more than one exist, and try to avoid the 5.5 and 5.6 codes.</p> <p>^b See further information in B.2.3.2 and also F.3.2.</p>				

Table B.3 (continued)

Code number	Notation	Subdivision code number	Subdivision of the failure cause	Description of the failure cause
5	Miscellaneous ^a	5.0	Miscellaneous - general	Causes that do not fall into one of the categories listed above
		5.1	No cause found	Failure investigated but no specific cause found
		5.2	Common cause	Common cause/mode ^b
		5.3	Combined causes	Several causes are acting simultaneously. If one cause is predominant, this cause should be highlighted
		5.4	Other unit/ cascading failure	Failure caused by the failure of another equipment unit, subunit or maintainable item (cascading failure)
		5.5	Other	None of the above codes applies. Specify cause as free text
		5.6	Unknown	No information available related to the failure cause
^a The data acquirer should judge which is the most important cause if more than one exist, and try to avoid the 5.5 and 5.6 codes. ^b See further information in B.2.3.2 and also F.3.2.				

B.2.3.2 Common cause failures

Common cause failures are already defined in other standards, such as IEC 61508:2010 and ISO/TR 12489:2013. RM data collection shall take such failures into account. How to deal with common cause failures depends on the taxonomy level (ref [Figure 3](#)) where the collection is done and the level on which the common cause failures occur. If a common cause failure occurs on the same level as the data collection or any level above, the failure should be registered for each individual item. However, only one of the items should be selected where the actual failure cause is described. This item should be the first or most severely affected, if this is possible to identify. Otherwise, this item is selected randomly. For all the other failed items, the failure cause should be labelled with “common cause”.

For example, if a failure on a subsea umbilical reveals that all cores have been wrongly configured (design error), and data is collected on maintainable item level, in this case the individual umbilical lines, the following procedure is recommended: Record one failure for each of the umbilical lines, which typically consist of power/signal lines and hydraulic/chemical lines. For only one of these, record the failure cause as “design error”. For all the others, record the failure cause as “common cause”. On topside equipment units, common cause failures can typically occur for driver/driven unit, or parallel configurations of rotating equipment. In those cases, the method as described shall apply.

If there is more than one failure on any level below the unit where data is collected, only one failure shall be recorded. However, the record shall indicate that several units on a lower hierarchical level have been affected. If contaminated lubrication oil causes damage on several subunits, there is only one failure to be recorded on the equipment unit. The subunit failed, shall either be labelled “several” or show a list of all affected subunits.

Sometimes, seemingly simultaneous failures are actually consequences of each other. According to ISO/TR 12489:2013, 3.2.14, this is not a common cause failure. Consequently, only the first (initiating) failure shall be recorded. An example of this is malfunctioning of the lube oil pump and subsequent bearing failure due to overheating. In this case, the failure shall only be recorded on the lubrication subunit.

See also information in F.3.2 with respect to common cause failures and relations to systematic failures.

B.2.4 Detection method

This is the method or activity by which a failure is discovered. This information is vitally important when evaluating the effect of maintenance, e.g. to distinguish between failures discovered by a planned

action (inspection, PM maintenance) or by chance (casual observation). Nine categories of detection methods are identified in [Table B.4](#), together with related codes to be used in the databases.

Table B.4 — Detection method

Number	Notation ^a	Description	Activity
1	Periodic maintenance	Failure discovered during preventive service, replacement or overhaul of an item when executing the preventive maintenance programme	Scheduled activities
2	Functional testing	Failure discovered by activating an intended function and comparing the response against a predefined standard. This is one typical method for detecting hidden failures	
3	Inspection	Failure discovered during planned inspection, e.g. visual inspection, non-destructive testing	
4	Periodic condition monitoring ^b	Failures revealed during a planned, scheduled condition monitoring of a predefined failure mode, either manually or automatically, e.g. thermography, vibration measuring, oil analysis, sampling	
5	Pressure testing ^c	Failure observed during pressure testing	
6	Continuous condition monitoring ^b	Failures revealed during a continuous condition monitoring of a predefined failure mode	Continuous monitoring
7	Production interference	Failure discovered by production upset, reduction, etc.	
8	Casual observation	Casual observation during routine or casual operator checks, mainly by senses (noise, smell, smoke, leakage, appearance, etc.)	Casual occurrences
9	Corrective maintenance	Failure observed during corrective maintenance	
10	On demand	Failure discovered during an on-demand attempt to activate an equipment unit (e.g. safety valve fails to close on ESD-signal, fail to start a gas turbine on demand, etc.)	
11	Other	Other observation method and/or combination of several methods	Other

^a Specific notation for fire and gas detectors, process sensors and control logic units: The codes above should be interpreted as follows:

functional test: periodic functional testing

casual observation: field observation

periodic CM: abnormal state discovered by control room personnel (no fault annunciation)

continuous CM: fault annunciation in control room (audible and/or visible alarm)

^b Condition monitoring implies use of specific equipment and/or algorithms to monitor the condition of the equipment with respect to predefined failure modes (note that “test” and “inspection” are separate codes). Condition monitoring (CM) can be further divided into:

1) periodic CM: periodic condition monitoring includes techniques such as thermography, off-line vibration measuring, oil analyses, calibration checks and sampling;

2) continuous CM: continuous instrumental surveillance of process parameters and equipment condition, e.g. temperature, pressure, flow, RPM, to detect abnormal operating conditions.

^c Pressure testing and functional testing are two different types of tests with different purposes to reveal external or internal leakage, as also reflected in Annex F.4.

B.2.5 Maintenance activity

Twelve categories of maintenance activity are identified in [Table B.5](#) together with related codes to be used in databases for both corrective maintenance and preventive maintenance.

Table B.5 — Maintenance activity

Code Number	Activity	Description	Examples	Use ^a
1	Replace	Replacement of the item by a new or re-furbished item of the same type and make	Replacement of a worn-out bearing	C, P
2	Repair	Manual maintenance action performed to restore an item to its original appearance or state	Repack, weld, plug, reconnect, re-make, etc.	C
3	Modify ^b	Replace, renew or change the item, or a part of it, with an item/part of a different type, make, material or design	Install a filter with smaller mesh diameter, replace a lubrication oil pump with another type, reconfiguration etc.	C, P
4	Adjust	Bringing any out-of-tolerance condition into tolerance	Align, set and reset, calibrate, balance	C, P
5	Refit	Minor repair/servicing activity to bring back an item to an acceptable appearance, internal and external	Polish, clean, grind, paint, coat, lube, oil change, etc.	C, P
6	Check ^c	The cause of the failure is investigated, but no maintenance action performed, or action is deferred. Able to regain function by simple actions, e.g. restart or resetting.	Restart, resetting, no maintenance action, etc. Particularly relevant for functional failures, e.g. fire and gas detectors, subsea equipment	C
7	Service	Periodic service tasks: Normally no dismantling of the item	e.g. cleaning, replenishment of consumables, adjustments and calibrations	P
8	Test	Periodic test of function or performance	Function test of gas detector, accuracy test of flow meter	P
9	Inspection	Periodic inspection/check: a careful scrutiny of an item carried out with or without dismantling, normally by use of senses	All types of general check. Includes minor servicing as part of the inspection task	P
10	Overhaul	Major overhaul	Comprehensive inspection/overhaul with extensive disassembly and replacement of items as specified or required	C, P
11	Combination	Several of the above activities are included	If one activity dominates, this may alternatively be recorded	C, P
12	Other	Maintenance activity other than specified above	e.g. protection activities	C, P

^a C: used typically in corrective maintenance; P: used typically in preventive maintenance.
^b Modification is not defined as a maintenance category, but is often performed by persons trained in the maintenance disciplines. Modification to a major extent can have influence on the operation and reliability of an equipment unit.
^c "Check" includes the both where a failure cause was revealed but maintenance action was considered either not necessary or not possible to carry out and where no failure cause circumstances could be found.

For corrective maintenance, this information describes the type of restoration action that was performed. In general, the predominant restoration activity should be coded when several activities are involved. The code categories "repair", "replace", "overhaul" and "modify" should have a priority relative to the code categories "refit" and "adjust" when a combination of the two categories are involved (e.g. repair consisting of "repair" and "refit" should be coded as "repair"). If there are several repair activities involved, none of which is predominant, the code "combined" may be used.

"Modify" means a modification of the original equipment unit where the original design has been altered or the item in question replaced with one of a different type/make. If the modification is of significant character, it is not considered as a maintenance action, but may be carried out by, or in cooperation with, the maintenance staff. A "repair" is meant to be an action to correct a single failure or a few failures, normally on-site. "Overhaul" means a comprehensive repair of several failures, or one major failure requiring extensive work, or complete refurbishment of an equipment subunit. Typically, such maintenance is undertaken in a workshop.

If the complete equipment unit has been replaced with a new and/or modified one, it is recommended to rewind the time parameters (e.g. operating time) for this unit. This does not apply if the equipment unit is of low complexity and a complete replacement is considered as a normal part of the maintenance.

For preventive maintenance, this information describes the type of preventive action being performed. In general, the most predominant maintenance activity should be coded when several activities are involved. If there is no predominant task, again this should be coded as “combined” and additional information on the various activities listed in a free-text field if provided.

NOTE These maintenance codes do not, as such, reflect the effectiveness of the maintenance action as to restoring the condition of the item (e.g. “good-as-new” or “bad-as-old” condition).

B.2.6 Failure modes

Failure modes should normally relate to the equipment-class level in the hierarchy. For subsea equipment, however, it is recommended to also record failure modes on lower levels in the equipment hierarchy (e.g. “maintainable-item” level). The failure modes can be categorized into three types:

- a) desired function is not obtained (e.g. failure to start);
- b) specified function lost or outside accepted operational limits (e.g. spurious stop, high output);
- c) failure indication is observed but there is no immediate and critical impact on the equipment-unit function [these are typically non-critical failures related to some degradation or incipient fault condition (e.g. initial wear)].

See also [Table 3](#), and note some of the failure modes may apply on other levels

Failure modes are presented in [Tables B.6 to B.14](#) for each main equipment category shown in [Table A.4](#). [Table B.15](#) presents a summary of all failure modes. Recommended failure modes are presented for each main equipment category (see also list of equipment presented in [Table A.4](#)):

- rotating (combustion engines, compressors, electric generators, gas turbines, etc.);
- mechanical (cranes, heat exchangers, heaters and boilers, pressure vessels, storage tanks, piping, etc.);
- electrical (uninterruptable power supply, power transformers, frequency converters, etc.);
- safety and control (fire and gas detectors, input devices, control logic units, valves, nozzles, etc.);
- subsea (subsea production control, subsea wellhead and X-mas trees, risers, subsea pumps, etc.);
- well completion (surface wellhead and X-mas trees, downhole safety valves, electrical submersible pumps, etc.);
- drilling (subsea blowout preventers (BOP), surface blowout preventers (BOP), top drives, etc.);
- well intervention (surface well control equipment, subsea well intervention: open water intervention, etc.);
- marine (e.g. jacking and fixation).

In the following [Tables B.6 to B.14](#), showing the recommended failure modes, the codes shown apply to equipment classes marked with “X”. The proposed abbreviated code for the failure modes are given in the first column of the tables. The failure mode “other” or “unknown” are needed in case failure modes do not apply. If many failures with “other” are recorded, this can later create a basis for a new failure mode to come in these tables.

ISO 14224:2016(E)

Note that some examples apply to only some of the equipment classes in the table they appear. See also [Table 3](#), and note some of the failure modes may apply on other levels.

NOTE The failure mode codes in [Tables B.6](#) to [B.15](#) are issued as part of [Annex B](#), but are also shown in an Excel document that is available at <http://standards.iso.org/iso/14224>. This facilitates the use and application of these codes by the users of this International Standard. Some of the tables have notes that are not shown in the Excel document.

Table B.6 — Rotating equipment — Failure modes

Failure mode code	Description	Equipment class code	CE	CO	EG	EM	GT	PU	ST	TE
		Examples	Com-bustion engines	Com-pres-sors	Electric genera-tors	Electric motors	Gas tur-bines	Pumps	Steam tur-bines	Tur-bo-ex-pand-ers
AIR	Abnormal instrument reading	False alarm, faulty instrument indication	X	X	X	X	X	X	X	X
BRD	Breakdown	Serious damage (seizure, breakage)	X	X	X	X	X	X	X	X
ERO	Erratic output	Oscillating, hunting, instability	X	X		X	X	X	X	X
ELF	External leakage - fuel	External leakage of supplied fuel/gas	X				X		X	
ELP	External leakage - process medium	Oil, gas, condensate, water		X			X	X	X	X
ELU	External leakage – utility medium	Lubricant, cooling water	X	X	X	X	X	X	X	X
FTS	Failure to start on demand	Doesn't start on demand	X	X	X	X	X	X	X	X
HIO	High output	Overspeed/output above acceptance	X	X		X	X	X	X	X
INL	Internal leakage	Leakage internally of process or utility fluids	X	X			X	X	X	X
LOO	Low output	Delivery/output below acceptance	X	X	X	X	X	X	X	X
NOI	Noise	Abnormal noise	X	X	X	X	X	X	X	X
OHE	Overheating	Machine parts, exhaust, cooling water	X	X	X	X	X	X	X	X
PDE	Parameter deviation	Monitored parameter exceeding limits, e.g. high/low alarm	X	X	X	X	X	X	X	X
PLU	Plugged/ choked	Flow restriction(s)	X	X			X	X	X	X
SER	Minor in-service problems	Loose items, discoloration, dirt	X	X	X	X	X	X	X	X
STD	Structural deficiency	Material damages (cracks, wear, fracture, corrosion)	X	X	X	X	X	X	X	X
STP	Failure to stop on demand	Doesn't stop on demand	X	X	X	X				
OTH	Other	Failure modes not covered above	X	X	X	X	X	X	X	X
UNK	Unknown	Too little information to define a failure mode	X	X	X	X	X	X	X	X
UST	Spurious stop	Unexpected shutdown	X	X	X	X	X	X	X	X
VIB	Vibration	Abnormal vibration	X	X	X	X	X	X	X	X

Table B.7 — Mechanical equipment — Failure modes

Failure mode code	Description	Equipment class code Examples	CR	HE	HB	PI	VE	WI	TU	SW	TA
			Cranes	Heat exchangers	Heaters and boilers	Piping	Pressure vessels	Winches	Turrets	Swivels	Storage tanks
AIR	Abnormal instrument reading	False alarm, faulty instrument indication	X	X	X	X	X	X	X	X	X
BRD	Breakdown	Breakdown	X			X		X			
ELP	External leakage - process medium	Oil, gas, condensate, water		X	X	X	X			X	X
ELU	External leakage - utility medium	Lubricant, cooling water, barrier oil	X	X	X	X	X	X		X	X
FCO	Failure to connect	Failure to connect							X	X	
IHT	Insufficient heat transfer	Missing, or too low, heat transfer			X						
		Cooling/heating below acceptance		X			X				X
INL	Internal leakage	Leakage internally of process or utility fluids	X	X	X	X				X	X
FLP	Failure in lightning protection system	Failure in grounding, insufficient roof thickness, etc.									X
FRO	Failure to rotate	Failure to rotate	X					X	X	X	
FTD	Failure to disconnect	Failure to disconnect upper connector							X		
FTI	Failure to function as intended	General operation failure	X						X	X	
FTS	Failure to start on demand	Failure to start on demand	X					X			
LBP	Low oil supply pressure	Low oil supply pressure								X	
LOA	Load drop	Load drop	X					X			
LOB	Loss of buoyancy	Loss of buoyancy in idle position							X		X
LOO	Low output	Performance below specifications						X			
MOF	Mooring failure	Mooring failure							X		
NOI	Noise	Excessive noise	X			X		X	X		
OHE	Overheating	Overheating	X		X	X		X			
OTH	Other	Failure modes not covered above	X	X	X	X	X	X	X	X	X
PDE	Parameter deviation	Monitored parameter exceeding limits, e.g. high/low alarm	X	X	X	X	X	X	X	X	X
PLU	Plugged/ choked	Flow restriction due to contamination, objects, wax, etc.		X	X	X	X			X	X
PTF	Power/signal transmission failure	Power/signal transmission failure				X				X	

Table B.7 (continued)

Failure mode code	Description	Equipment class code Examples	CR	HE	HB	PI	VE	WI	TU	SW	TA
			Cranes	Heat exchangers	Heaters and boilers	Piping	Pressure vessels	Winches	Turrets	Swivels	Storage tanks
SBU	Sludge build-up	Sludge build-up					X				X
SER	Minor in-service problems	Loose items, discoloration, dirt	X	X	X	X	X	X	X	X	X
SLP	Slippage	Wire slippage	X					X			
SPO	Spurious operation	Unexpected operation	X					X			
STD	Structural deficiency	Material damages (cracks, wear, fracture, corrosion)	X	X	X	X	X	X	X	X	X
STP	Failure to stop on demand	Failure to stop on demand						X			
UNK	Unknown	Too little information to define a failure mode	X	X	X	X	X	X	X	X	X
VIB	Vibration	Excessive vibration	X			X		X			

Table B.8 — Electrical equipment — Failure modes

Failure mode code	Description	Equipment class code Examples	UP	PT	FC	SG
			Uninterruptible power supply	Power transformers	Frequency converters	Switch-gear
AIR	Abnormal instrument reading	Wrong oil level indication, False alarm, faulty instrument indication		X	X	
BRD	Breakdown	Serious damage			X	
DOP	Delayed operation	Delayed response to commands			X	
ELU	External leakage - utility medium	Leakage of oil leakage, lubricant, cooling water		X	X	X
ERO	Erratic output	Oscillating, hunting, instability	X		X	
FOF	Faulty output frequency	Wrong/oscillating frequency	X			
FOV	Faulty output voltage	Wrong/unstable output voltage	X	X		
FTC	Failure to close on demand	Circuit breaker/switchfuse/disconnector/bus tie fails to close when demanded				X
FTF	Failure to function on demand	Doesn't start on demand, or failure to respond on signal/ activation, or does not respond to input commands	X	X	X	
		Auxiliary function, subsystem, monitoring or control device fails to operate when demanded				X
FTI	Failure to function as intended	Response not as expected			X	
		Protection device/ circuit breaker/ switch fails to clear a fault on the circuit				X
FTO	Failure to open on demand	Circuit breaker/switchfuse/disconnector/bus tie fails to open when demanded				X
FTR	Failure to regulate	Fails to control the load, poor response to feedback			X	
HIO	High output	Overspeed/output above acceptance			X	
INL	Internal leakage	Oil leakage, Leakage internally process or utility fluids		X	X	
LOO	Low output	Delivery/output below acceptance			X	
NOI	Noise	Abnormal noise				X
OHE	Overheating	Machine parts, exhaust, cooling water	X	X	X	
OHE	Overheating	Too high internal temperature				X
OTH	Other	Failure modes not covered above	X	X	X	X
PDE	Parameter deviation	Monitored parameter exceeding limits, e.g. high/low alarm	X	X	X	
PLU	Plugged/ choked	Obstructed piping		X		

Table B.8 (continued)

Failure mode code	Description	Equipment class code Examples	UP	PT	FC	SG
			Uninterruptible power supply	Power transformers	Frequency converters	Switchgear
SER	Minor in-service problems	Loose items, discoloration, dirt	X	X	X	
SPO	Spurious operation	Intermittent disconnection or connection unintended operation.				X
		Unexpected operation	X		X	
STD	Structural deficiency	Reservoir rupture		X		
UNK	Unknown	Too little information to define a failure mode	X	X	X	X
UST	Spurious stop	Unexpected shutdown			X	
		Unintended disconnection of a circuit				X
VIB	Vibration	Abnormal vibration				X

Table B.9 — Safety and control equipment — Failure modes

Failure mode code	Description	Equipment class code Examples	FGA	FGB	IP	CL	VA	NO	LB
			Fire detection	Gas detection	Input devices	Control logic units	Valves	Nozzles	Lifeboats
AIR	Abnormal instrument reading	False alarm, faulty instrument indication					X		X
BRD	Breakdown	Breakdown, serious damage (seizure, breakage), and/or major process fluid leak							X
DOP	Delayed operation	Opening/closing time below spec.					X	X	X
ELP	External leakage - process medium	Oil, gas, condensate, water			X		X		
ELU	External leakage - utility medium	Hydraulic oil, lubrication oil, barrier oil, coolant, water, etc.			X		X		X
ERO	Erratic output	Oscillating, hunting, instability	X	X	X	X			
FTC	Failure to close on demand	Doesn't close on demand					X		
FTF	Failure to function on demand	Failure to respond on signal/activation	X	X	X	X			X
FTO	Failure to open on demand	Doesn't open on demand, stuck closed or fail to open fully					X	X	
FTS	Failure to start on demand	Doesn't start on demand							X
HIO	High output	Overspeed/output above acceptance	X	X	X	X	X		
INL	Internal leakage	Leakage internally of process or utility fluids					X		X
LCP	Leakage in closed position	Leak through valve in closed position					X		
LOA	Load drop	Unintended drop/launch of a lifeboat							X
LOO	Low output	Delivery/output below acceptance	X	X	X	X	X		X
NOI	Noise	Abnormal or excessive noise					X		X
NOO	No output	No output	X	X	X				
OHE	Overheating	Machine parts, exhaust, cooling water, etc.							X
OTH	Other	Failure modes not covered above	X	X	X		X	X	X
PLU	Plugged/ choked	Partial or full flow restriction					X	X	

Table B.9 (continued)

Failure mode code	Description	Equipment class code Examples	FGA	FGB	IP	CL	VA	NO	LB
			Fire detection	Gas detection	Input devices	Control logic units	Valves	Nozzles	Lifeboats
POW	Insufficient power	Lack of or too low power supply							X
PTF	Power/signal transmission failure	Power/signal transmission failure							X
SER	Minor in-service problems	Loose items, discoloration, dirt	X		X	X	X	X	X
SHH	Spurious high alarm level	e.g. 60 % of Lower Explosive Limit (LEL)	X	X					
SLL	Spurious low alarm level	e.g. 20 % of Lower Explosive Limit (LEL)	X	X					
SLP	Slippage	Wire slippage							X
SPO	Spurious operation	e.g. false alarm	X	X	X	X			
		Undesired opening						X	
		Fails to operate as demanded, false alarm, premature closure/stop, unexpected operation/fails to operate as demanded					X		X
STD	Structural deficiency	Material damages (cracks, wear, fracture, corrosion), reduced integrity					X	X	X
STP	Failure to stop on demand	Doesn't stop on demand							X
UNK	Unknown	Too little information to define a failure mode	X	X	X	X	X		X
UST	Spurious stop	Unexpected shutdown							X

Table B.9 (continued)

Failure mode code	Description	Examples	Equipment class code														
			FGA Fire detection	FGB Gas detection	IP Input devices	CL Control logic units	VA Valves	NO Nozzles	LB Lifeboats								
VIB	Vibration	Abnormal/excessive vibration					X		X								
VLO	Very low output	e.g. reading between 11 % LEL to 30 % Lower Explosive Limit (LEL) upon test gas.		X													
<p>NOTE 1 Failure coding for fire and gas detectors: For fire and gas detectors, it is important that all failures are recorded; also those detected during scheduled testing and those detected in operation, e.g. replacement of a detector head should be recorded, even if this is done as part of the preventive maintenance programme. Typical failure modes are the following:</p> <ul style="list-style-type: none"> • failure to function: The detector does not respond when exposed to its relevant stimulus (e.g. gas or heat). This failure mode is normally observed during functional testing; • spurious operation: The detector gives an alarm signal when it is not exposed to relevant stimulus. This failure mode is normally observed during operation and logged by control-room personnel; • others: Additionally, some failure modes related to low/high output, adjustments and overhauls will typically be found in the log books. <p>NOTE 2 Failure coding for gas detectors:</p> <table> <tr> <td>High output</td> <td>e.g. reading 10 % LEL to 20 % LEL without test gas; reading above 80 % LEL on test gas.</td> </tr> <tr> <td>Low output</td> <td>e.g. reading between 31 % LEL to 50 % LEL upon test gas (assuming a nominal set point of 65 % LEL).</td> </tr> <tr> <td>Very low output</td> <td>e.g. reading between 11 % LEL to 30 % LEL upon test gas.</td> </tr> <tr> <td>No output</td> <td>e.g. reading less than 10 % LEL upon test gas.</td> </tr> </table>										High output	e.g. reading 10 % LEL to 20 % LEL without test gas; reading above 80 % LEL on test gas.	Low output	e.g. reading between 31 % LEL to 50 % LEL upon test gas (assuming a nominal set point of 65 % LEL).	Very low output	e.g. reading between 11 % LEL to 30 % LEL upon test gas.	No output	e.g. reading less than 10 % LEL upon test gas.
High output	e.g. reading 10 % LEL to 20 % LEL without test gas; reading above 80 % LEL on test gas.																
Low output	e.g. reading between 31 % LEL to 50 % LEL upon test gas (assuming a nominal set point of 65 % LEL).																
Very low output	e.g. reading between 11 % LEL to 30 % LEL upon test gas.																
No output	e.g. reading less than 10 % LEL upon test gas.																

Table B.10 — Subsea equipment — Failure modes

Failure mode code	Description	Examples	Equipment class code						
			CS Subsea production control	XT Subsea well-head and X-mas trees	SP Subsea pumps	PR Risers	EPD Subsea electrical power distribution	SV Subsea pressure vessels	SL Subsea pipelines
AIR	Abnormal instrument reading	False alarm, faulty instrument indication	X		X		X	X	X
BRD	Breakdown	Breakdown, serious damage (seizure, breakage), and/or major process fluid leak					X		
CSF	Control/ signal failure	No, or faulty monitoring or regulation, failure to transmit or receive command or data, failure to actuate function	X				X		
DOP	Delayed operation	Opening/closing time below spec.		X		X			X
ELP	External leakage - process medium	Oil, gas, condensate, water	X	X	X	X		X	X
ELU	External leakage - utility medium	Hydraulic oil, lubrication oil, barrier oil, coolant, water, etc.	X	X	X	X	X	X	X
FCO	Failure to connect	Failure to connect connector		X	X		X	X	
FTC	Failure to close on demand	Doesn't close on demand		X					X
FTD	Failure to disconnect	Failure to disconnect connector		X	X		X	X	
FTF	Failure to function on demand	Failure to respond on signal/activation	X		X				X
FTL	Failure to lock/unlock	Doesn't lock or unlock when demanded, failure to connect or disconnect, failure to release SCM from its mounting base	X	X					X
FTO	Failure to open on demand	Doesn't open on demand		X					X
HIO	High output	Overspeed/ output above acceptance			X				
HTF	Heating failure	Loss of ability to provide heating							X
IHT	Insufficient heat transfer	Lack off or reduced ability to transfer heat from hot temperature areas, such as power transformers or power supply electronics					X	X	
ILP	Internal leakage - process medium	Leakage process medium going through heat coils or similar.						X	
ILU	Internal leakage - utility medium	Leakage internally of utility fluids	X	X	X	X	X	X	X

Table B.10 (continued)

Failure mode code	Description	Examples	Equipment class code						
			CS Subsea production control	XT Subsea well-head and X-mas trees	SP Subsea pumps	PR Risers	EPD Subsea electrical power distribution	SV Subsea pressure vessels	SL Subsea pipelines
LCP	Leakage in closed position	Leak through valve in closed position		X		X			X
LOO	Low output	Delivery/output below acceptance Delivery/output/torque/performance below acceptance	X		X		X		
OTH	Other	Failure modes not covered above	X	X	X	X	X	X	X
PDE	Parameter deviation	Monitored parameter exceeding limits, e.g. high/low alarm						X	
PLU	Plugged/ choked	Partial or full flow restriction		X		X		X	X
POW	Insufficient power	Lack of or too low power supply	X	X			X		X
SER	Minor in-service problems	Loose items, discoloration, dirt						X	
SET	Failure to set/retrieve	Failed set/retrieve operations	X	X	X		X	X	X
SPO	Spurious operation	Fails to operate as demanded, false alarm, premature closure/stop, unexpected operation/fails to operate as demanded	X	X	X		X		X
STD	Structural deficiency	Material damages (cracks, wear, fracture, corrosion) Material damages (cracks, wear, fracture, corrosion, decay)		X		X	X	X	X
UBU	Global buckling	Upheaval or lateral buckling							X
UNK	Unknown	Too little information to define a failure mode					X	X	X

NOTE Although not a requirement of this International Standard, it is recommended that, for subsea equipment, failure modes are also recorded at a lower hierarchical level, e.g. "maintainable item".

Table B.11 — Well completion equipment — Failure modes

Failure mode code	Description	Equipment class code Examples	ESP	SS	XD
			Electrical submersible pumps	Down-hole safety valves	Surface well-head and X-mas trees
AIR	Abnormal instrument reading	False alarm, faulty instrument indication	X		
BRD	Breakdown	Serious damage (seizure, breakage)	X		
CLW	Control-line-to-well communication	Loss of hydraulic control fluids into the well bore		X	
ELP	External leakage - process medium	Oil, gas, condensate, water Process medium leak to environment	X		X
ELU	External leakage - utility medium	Lubricant, cooling water, hydraulic fluid, methanol, etc.	X		X
ERO	Erratic output	Oscillating, hunting, instability	X		
FTC	Failure to close on demand	Does not close upon demand signal Valve(s) fail to close on demand		X	X
FTF	Failure to function on demand	Failure to respond on signal/activation	X		
FTO	Failure to open on demand	Does not open on demand Valve(s) fail to open on demand		X	X
FTS	Failure to start on demand	Doesn't start on demand	X		
HIO	High output	Overspeed/output above acceptance	X		
ILP	Internal leakage - process medium	Leakage internally of process fluids			X
ILU	Internal leakage - utility medium	Leakage internally of utility fluids	X		X
INL	Internal leakage	Leakage internally of process or utility fluids	X		
LCP	Leakage in closed position	Leakage through valve exceeding acceptance criteria when closed		X	
LOO	Low output	Delivery/output below acceptance	X		
OHE	Overheating	Machine parts, exhaust, cooling water	X		
OTH	Other	Failure modes not covered above Specify in comment field	X	X	X
PCL	Premature closure	Spurious closure of valve without command		X	
PDE	Parameter deviation	Monitored parameter exceeding limits, e.g. high/low alarm	X		

Table B.11 (continued)

Failure mode code	Description	Examples	Equipment class code		
			ESP	SS	XD
			Electrical submersible pumps	Down-hole safety valves	Surface well-head and X-mas trees
PLU	Plugged/ choked	Partly or full flow restriction due to hydrate, scale, wax, etc.	X		X
SPO	Spurious operation	Fails to operate as demanded Undesired valve opening / closure	X		X
STD	Structural deficiency	Material damages (cracks, wear, fracture, corrosion) Reduced integrity	X		X
UNK	Unknown	Too little information to define a failure mode	X	X	X
UST	Spurious stop	Unexpected shutdown	X		
VIB	Vibration	Abnormal vibration	X		
WCL	Well-to-control-line communication	Influx of well fluids into valve control line		X	

Table B.12 — Drilling equipment — Failure modes

Failure mode code	Description	Equipment class code Examples	TD	SB	DB
			Top drives	Subsea blowout preventers (BOP)	Surface blowout preventers (BOP)
AIR	Abnormal instrument reading	False alarm, faulty instrument indication	X	X	X
ELP	External leakage - process medium	Well fluids		X	X
ELU	External leakage - utility medium	Hydraulic oil, lubrication oil, coolant, mud, water, etc.	X	X	X
ERO	Erratic output	Oscillating or instable operation	X	X	X
FCO	Failure to connect	Failure to connect connector		X	X
FCU	Failure to cut	Shear cut valve unable to cut equipment		X	X
FTC	Failure to close on demand	Doesn't close on demand		X	X
FTD	Failure to disconnect	Failure to disconnect connector		X	X
FTF	Failure to function on demand	Failure to respond on signal/activation (e.g. failure to shear)		X	X
FTO	Failure to open on demand	Doesn't open on demand		X	X
FTS	Failure to start on demand	Failure to start top drive	X		
HIO	High output	Output torque above specifications	X		
INL	Internal leakage	Leakage internally of process or utility fluids	X	X	X
LCP	Leakage in closed position	Leakage through a valve (e.g. ram-valve) in closed position		X	X
LOO	Low output	Output torque below specifications	X		
NOI	Noise	Excessive noise	X		
OHE	Overheating	Overheating	X		
OTH	Other	Failure modes not covered above	X	X	X
PLU	Plugged / Choked	Choke or kill line plugged		X	X
POD	Loss of functions on both pods	Both pods are not functioning as desired		X	
SET	Failure to set/retrieve	Failed set/retrieve operations		X	X
SER	Minor in-service problems	Loose items, discoloration, dirt	X	X	X
SPO	Spurious operation	Unexpected operation	X	X	X
STD	Structural deficiency	Material damages (cracks, wear, fracture, corrosion)	X	X	X

Table B.12 (continued)

Failure mode code	Description	Equipment class code Examples	TD	SB	DB
			Top drives	Subsea blowout preventers (BOP)	Surface blowout preventers (BOP)
STP	Failure to stop on demand	Failure to stop top drive or incorrect shutdown process	X		
UNK	Unknown	Too little information to define a failure mode	X	X	X
VIB	Vibration	Excessive vibration	X		

Table B.13 — Well intervention — Failure modes

Fail- ure mode code	Description	Equipment class code	WC	OI
		Examples	Surface well control equip- ment (for well inter- vention)	Subsea well inter- vention: Open water interven- tion
BRD	Breakdown	Breakdown, serious damage (seizure, breakage), and/or major process fluid leak	X	X
CSF	Control / Signal failure	No, or faulty monitoring or regulation, failure to transmit or receive command or data, failure to actuate function	X	X
DOP	Delayed operation	Opening/closing time below spec.	X	X
ELP	External leakage - process medium	Well fluids	X	X
ELU	External leakage - utility medium	Hydraulic oil, lubrication oil, coolant, mud, water, etc.	X	X
ERO	Erratic output	Oscillating or instable operation	X	X
FCO	Failure to connect	Failure to connect connector	X	X
FCU	Failure to cut	Shear cut valve unable to cut equipment	X	X
FTC	Failure to close on demand	Doesn't close on demand	X	X
FTD	Failure to disconnect	Failure to disconnect connector	X	X
FTF	Failure to function on demand	Failure to respond on signal/activation (e.g. failure to shear)	X	X
FTO	Failure to open on demand	Doesn't open on demand	X	X
FWR	Failure while running	Unable to run equipment or tools		X
HIO	High output	Output torque above specifications		X
ILP	Internal leakage - process medium	Leakage process medium contaminating utility medium, Leakage internally of process fluids	X	X
ILU	Internal leakage - utility medium	Leakage internally of utility fluids, Loss of lubrication	X	X
LCP	Leakage in closed position	Leakage through a valve (e.g. ram-valve) in closed position	X	X
LOO	Low output	Output torque below specifications		X
OTH	Other	Failure modes not covered above	X	X
PLU	Plugged choked	Choke or kill line plugged	X	X
POW	Insufficient power	Lack of or too low power supply	X	X
PTF	Power/signal transmission failure	Power/signal transmission failure		X
SET	Failure to set/retrieve	Failed set/retrieve operations		X
SPO	Spurious operation	Unexpected operation	X	X
STU	Stuck	Tools becoming stuck in the BOP or X-mas Tree	X	X
UNK	Unknown	Too little information to define a failure mode	X	X

Table B.14 — Marine equipment — Failure modes

Failure mode code	Description	Equipment class code	JF
		Examples	Jacking and fixation
AIR	Abnormal instrument reading	False alarm, faulty instrument indication	X
BRD	Breakdown	Breakdown, serious damage (seizure, breakage), and/or major process fluid leak	X
DOP	Delayed operation	Opening/closing time below spec.	X
ELU	External leakage - utility medium	Hydraulic oil, lubrication oil, barrier oil, coolant, water, etc.	X
FRO	Failure to rotate	Failure to rotate	X
FTF	Failure to function on demand	Doesn't start or open on demand or failure to respond on signal/activation	X
FTL	Failure to lock/unlock	Doesn't lock or unlock when demanded	X
HIO	High output	Output torque above specifications or overspeed/output above acceptance	X
IHT	Insufficient heat transfer	Cooling/heating below acceptance and/or heat transfer too low	X
INL	Internal leakage	Leakage internally process or utility fluids	X
LBP	Low oil supply pressure	Low oil supply pressure	X
LOO	Low output	Delivery/output/torque/performance below acceptance	X
NOI	Noise	Abnormal or excessive noise	X
OHE	Overheating	Machine parts, exhaust, cooling water, etc.	X
OTH	Other	Failure mode(s) not covered above	X
PDE	Parameter deviation	Monitored parameter exceeding limits, e.g. High/Low alarm	X
PLU	Plugged/ choked	Flow restriction due to contamination, objects, wax etc.	X
POW	Insufficient power	Lack of or too low power supply	X
PTF	Power/signal transmission failure	Power/signal transmission failure	X
SER	Minor in-service problems	Loose items, discoloration, dirt	X
SPO	Spurious operation	False alarm, premature closure/stop, unexpected operation/fails to operate as demanded	X
STD	Structural deficiency	Material damages (cracks, wear, fracture, corrosion, decay)	X
UNK	Unknown	Too little information to define a failure mode	X
UST	Spurious stop	Unexpected shutdown	X
VIB	Vibration	Abnormal/excessive vibration	X

Table B.15 — Overview — Failure modes

Failure mode code	Failure mode description	On-demand type failure
AIR	Abnormal instrument reading	
BRD	Breakdown	
CLW	Control-line-to-well communication	
CSF	Control / signal failure	
^a See also footnote g in Table F.1 with respect to safety equipment.		

Table B.15 (continued)

Failure mode code	Failure mode description	On-demand type failure
DOP	Delayed operation	X
ELF	External leakage - fuel	
ELP	External leakage - process medium	
ELU	External leakage - utility medium	
ERO	Erratic output	
FCO	Failure to connect	X
FCU	Failure to cut	X
FLP	Failure in lightning protection system	
FOF	Faulty output frequency	
FOV	Faulty output voltage	
FRO	Failure to rotate	
FTC	Failure to close on demand	X
FTD	Failure to disconnect	X
FTF	Failure to function on demand	X
FTI	Failure to function as intended	X
FTL	Failure to lock/unlock	X
FTO	Failure to open on demand	X
FTR	Failure to regulate	X
FTS	Failure to start on demand	X
FWR	Failure while running	
HIO	High output	
HTF	Heating failure	
IHT	Insufficient heat transfer	
ILP	Internal leakage - process medium	
ILU	Internal leakage - utility medium	
INL ^a	Internal leakage	
LBP	Low oil supply pressure	
LCP	Leakage in closed position	
LOA	Load drop	
LOB	Loss of buoyancy	
LOO	Low output	
MOF	Mooring failure	
NOI	Noise	
NOO	No output	
OHE	Overheating	
OTH	Other	
PCL	Premature closure	
PDE	Parameter deviation	
PLU	Plugged/ choked	
POD	Loss of functions on both pods	X
POW	Insufficient power	
PTF	Power/signal transmission failure	
^a See also footnote g in Table F.1 with respect to safety equipment.		

Table B.15 (continued)

Failure mode code	Failure mode description	On-demand type failure
SBU	Sludge build-up	
SER	Minor in-service problems	
SET	Failure to set/retrieve	X
SHH	Spurious high alarm level	
SLL	Spurious low alarm level	
SLP	Slippage	
SPO	Spurious operation	
STD	Structural deficiency	
STP	Failure to stop on demand	X
STU	Stuck	
UBU	Global buckling	
UNK	Unknown	
UST	Spurious stop	
VIB	Vibration	
VLO	Very low output	
WCL	Well-to-control-line communication	
^a See also footnote g in Table F.1 with respect to safety equipment.		

Annex C (informative)

Guide to interpretation and calculation of derived reliability and maintenance parameters

C.1 Interpretation rules for commonly used failure and maintenance parameters

C.1.1 General

Though this International Standard does not cover data analysis in the broad sense, this annex includes some recommended interpretation rules and basic calculation formulas commonly used when analysing reliability and maintenance data. For a more in-depth assessment of this subject, we recommend textbooks on the subject and some of the standards listed in the Bibliography at the end of this International Standard. For the qualification of new technology, refer also to textbooks on expert judgements, e.g. Cooke (1992).

In addition to the definitions given in Clause 3, Annex C gives some interpretation rules for commonly used terms encountered in data collection and projects.

ISO/TR 12489:2013 does also provide useful information regarding various reliability and maintenance parameters for use in reliability modelling and calculation.

C.1.2 Redundancy

Redundancy may be applied as follows:

- a) passive (cold) standby: redundancy wherein part of the means for performing a required function is needed to operate, while the remaining part(s) of the means are inoperative until needed;
- b) active (hot) standby: redundancy wherein all means for performing a required function are intended to operate simultaneously;
- c) mixed: redundancy where a part of the redundant means “is on standby” and another part is “active” (example: three means, one active, one in hot standby, one in cold standby).

EXAMPLE 1 Redundancy can be expressed as a quantitative measure, viz. equipment redundancy factor (ERF).

EXAMPLE 2 3 units times 50 % gives an ERF of 1.5.

(See also definition of redundancy in Clause 3 and distinction between “hot” and “cold” standby versus “up time/down time” in 8.3.1).

For redundant systems, parts can fail without a failure of the system. This should be taken into account when estimating required spare parts and repair capacity (where these failures are counted) and estimates of availability (where these failures are not counted).

C.1.3 On-demand data

For some equipment, collected reliability data are used to estimate the on-demand failure probability (e.g. start probability of an emergency generator). Note also the definitions for “failure on demand” (see 3.30) and “failure due to demand” (see 3.25). In the estimation a distinction should be made between:

- a) failures occurred before demand occurs (undetected failures until revealed by real or periodic test demand);

b) failures occurring when demand occurs (due to demand itself).

Many failure modes (see Annex B) are such failures, and could be either type, but failure mechanism coding may enable to differ between “a” and “b” (see also C.3.4). Table B.15 shows failure modes which are on-demand related.

Furthermore, for some equipment, collected reliability data are also used to estimate the failure rate as a function of demands or number of cycles, rather than time, as explained in C.3.4. In this case, the total number of demands should be recorded. Two types of demands should be included (Ref. Table 5):

- a) test activation of the item normally done as part of preventive maintenance (e.g. function test of a fire and gas detector);
- b) automatic, or manual, activation of an on-demand function during operation (e.g. closure of an ESD valve).

For reliability data collection where such demand related failures are to be recorded, it is important to define more specifically the physical characteristics of the demands for the specific equipment that such data collection will cover.

For some equipment classes, like e.g. Piping, Heat exchangers, Risers, Filters and strainers, Power cables and terminations, the term, ‘demand’, is not meaningful.

For rotating equipment and some other equipment classes like Conveyors and elevators and Heaters and boilers, demand is interpreted as start-up. Thus, stopping the equipment, or any adjustment whilst running, like the speed of a VSD motor, is not to be interpreted as a demand.

For some mechanical equipment, like Cranes, Loading arms and Winches, demand is defined by the operation itself for which it is made.

For valves, both opening and closing is counted as a demand, regardless of the valve being normally closed or normally open. For control and choke valves, any adjustment is regarded as a demand.

For safety and control equipment or other equipment normally in stand-by mode, demand is defined as any activation, either test or real activation (e.g. real trip) during operation.

The probability of failure on demand is calculated as the average fraction of time spent in the failed state, as shown in C.6.2.

C.1.4 Independent failures

Most of the basic probabilistic calculations and most of the models used in the reliability field are relevant only for independent events.

Two events, A and B, are independent if the occurrence of A is independent of that of B. Mathematically speaking, that means that the conditional probability of occurrence of B given the occurrence of A, $P(B | A)$, is simply equal to $P(B)$.

Therefore, by using the definition of conditional probability:

$$P(B | A) = P(A \cap B) / P(A) = P(B) \tag{C.1}$$

This implies that:

$$P(A \cap B) = P(A) \cdot P(B) \tag{C.2}$$

When two events have the above property, that means that they behave independently from each other and they are said to be stochastically independent.

Independent failures are, of course, a particular case of independent events.

C.1.5 Dependent failures

When the occurrence of one event depends of the occurrence of one or several other events, these events are said to be dependent.

In this case, the above Formula (C.2) is no longer valid and it is necessary to replace it by Formula (C.3):

$$P(A \cap B) \neq P(A) \cdot P(B) \quad (\text{C.3})$$

Therefore, when the dependencies are not taken under consideration, the results are underestimated. As they are no longer conservative, this cannot be acceptable, especially for safety studies. This is why the concepts of common cause failure and common mode failure have been introduced.

Components that fail due to a shared cause normally fail in the same functional mode. The term common mode is, therefore, sometimes used. It is, however, not considered to be a precise term for communicating the characteristics that describe a common cause failure.

C.1.6 Common cause failure (CCF)

See definition in 3.5. Note the distinction between the type of common cause failures, which actually fails the items (e.g. component overvoltage) which have to be repaired separately, and the type of common cause failures which only make the items unavailable (e.g. loss of power supply). In the latter case, the items have not to be repaired.

A common cause failure is the simultaneous or concomitant failure of several components due to the same cause. Therefore, each time the failures are not completely independent there is a possibility of CCF.

The CCF can be split into several categories:

- a) failure of utilities (electricity, compressed air, etc.) or external aggressions (environment, fire, etc.);
- b) internal failures (design error, installation error, bad set of components, etc.);
- c) cascade failures (the failure of A leads to the failure of B, which leads to the failure of C, etc.).

Items listed in a) are considered as CCF only if the level of analysis is not sufficient in order to identify them explicitly.

Items listed in b) are more difficult to analyse: experience proves their existence but their causes are generally not identified very easily.

Items listed in c) are generally related to the process itself and can be difficult for the reliability analyst to identify.

When the analysis is too difficult or not possible, a β -factor is generally introduced to split the basic failure rate, λ , of a component into an independent part, $(1-\beta) \times \lambda$, and a CCF part, $\beta \times \lambda$. This avoids an unrealistic result, but is only an estimate in order to take into account the existence of a potential CCF. Refer to the shock model described in ISO/TR 12489:2013, Annex G.

It should also be noted that the analyst should be careful of what data is being used; see B.2.3.2. See also ISO/TR 12489:2013, 5.4.2.

C.1.7 Common mode failures (CMF)

See definition in 3.6.

The notion of common mode failure, CMF, is often confused with the notion of CCF, although it is a little bit different: a CMF occurs when several components fail in the same way (same mode). Of course, this can be due, in turn, to a CCF.

C.1.8 Trips

Shutdown of machinery refers to the situation when the machinery is shut down from normal operating condition to full stop. Two types of shutdown exist.

- a) Trip (see definition in 3.93).
- b) Manual shutdown: The machinery is stopped by an intended action of the operator (locally or from the control room).

For some equipment, spurious stop is defined as a failure mode (i.e. UST, see Table B.15) that can be either a real trip or a spurious trip depending on cause.

C.1.9 Failure occurrence classification

In conjunction with reliability analysis, e.g. FMECA, one can not necessarily have the access or need for statistical reliability data, but may have to use qualitative judgement. Table C.1 may be used to categorize failure occurrences, which can later during more in-depth analysis be verified with historic reliability data.

Table C.1 — Failure occurrence classification (modified, IEC 60812:2006, Table 5)

Failure mode occurrence	Rating	Frequency	Probability
Remote: Failure is unlikely	1	≤ 0,010 per thousand items	≤ 1 × 10 ⁻⁵
Low: Relatively few failures	2	0,1 per thousand items	1 × 10 ⁻⁴
	3	0,5 per thousand items	5 × 10 ⁻⁴
Moderate: Occasional failures	4	1 per thousand items	1 × 10 ⁻³
	5	2 per thousand items	2 × 10 ⁻³
	6	5 per thousand items	5 × 10 ⁻³
High: Repeated failures	7	10 per thousand items	1 × 10 ⁻²
	8	20 per thousand items	2 × 10 ⁻²
Very high: Failure is almost inevitable	9	50 per thousand items	5 × 10 ⁻²
	10	≥ 100 per thousand items	≥ 1 × 10 ⁻¹

C.1.10 Failure consequence classification

Risk is a commonly used term describing a triplet of, possible events, possible outcomes and the associated uncertainties of the events and outcomes (for one definition, see e.g. ISO 31000:2009). As part of a typical risk assessment, is estimating the likelihood of hazardous events that can occur and of the consequences expected to follow from the events. Note that these consequence is a systemic property and that the effect of a given failure mode can change according to way it is used within a system.

Failure consequence ranking is an essential part of data applications used to assess the risk level (see Annex D). It is, therefore, useful to classify the consequence of failures as to overall impact. A classification of failure consequences, with classes represented by numbers I to XVI, is illustrated in Table C.1. Note that this classification is primarily intended for assessing the consequences of failures that have occurred. For more detailed recommendations on risk classification, see relevant standards, e.g. ISO 17776:2000.

The recording of failure and maintenance impact data for failure events is addressed in Tables 6 and 8.

Table C.2 — Failure-consequence classification

Consequences	Category			
	Catastrophic Failure that results in death or system loss	Severe Severe injury, illness or major system damage	Moderate Minor injury, illness or system damage	Minor Less than minor injury, illness or system damage
Safety	I — Loss of lives — Vital safety-critical systems inoperable	V — Serious personnel injury — Potential for loss of safety functions	IX — Injuries requiring medical treatment — Limited effect on safety functions	XIII — Injuries not requiring medical treatment — Minor effect on safety function
Environmental	II Major pollution	VI Significant pollution	X Some pollution	XIV No, or negligible, pollution
Production	III Extensive stop in production/operation	VII Production stop above acceptable limit ^a	XI Production stop below acceptable limit ^a	XV Production stop minor
Operational	IV Very high maintenance cost	VIII Maintenance cost above normal acceptable ^a	XII Maintenance cost at or below normal acceptable ^a	XVI Low maintenance cost
^a It is necessary to define acceptable limits for each application.				

C.1.11 Analysis of failures

Failures that occur and that are judged to be in the unacceptable category in Table C.1 require that specific reporting and analyses be done in order to find measures to prevent such failure from re-occurring (e.g. improved maintenance, inspections, modifications, replacements etc.). Some useful analytical methods are summarized below.

- a) Reliability system modelling (e.g. Monte Carlo simulation, Markov analysis, reliability growth modelling etc.) is recommended for all critical-service equipment for the comparison of reliability for various proposed system configurations to provide input to concept selection in the development of the design basis. Specifically,
 - sensitivity studies to identify the component failures or human errors, or both, having the greatest impact on system reliability (this information can be used to improve the reliability of individual components or to provide a basis for modifying the system configuration during the project proposal),
 - evaluation of operational inspection intervals that have direct impact on predicted system reliability,
 - establishment of the amount of inspection and testing required for certain system elements.
- b) Pareto analysis can be utilized to establish the plant's list of "bad actors" based on the highest failure rates or total maintenance cost. Bad Actors' can also be related to cost of lost production and unacceptable level of safety.
- c) Root-cause analysis is recommended in the following cases:
 - failures of severity types I to VIII;
 - systems defined as "bad actors" by the operating facility.

- d) Equipment lifetime analysis, such as Weibull analysis, is recommended on equipment types having five or more common mode failures with severity levels I to XII.

NOTE Common causes of failures can be classified as follows.

- 1) Infant-mortality failures (Weibull-shape parameter $\beta < 1,0$) are usually induced by external circumstances and are typically due to poor installation, solid-state electronic failures, manufacturing defects, misassembly, or incorrect start-up procedures.
- 2) Random failures ($\beta = 1,0$) most often result from human errors, foreign-object failures or computational errors in the Weibull analysis (e.g. combining data from different failure modes, combining common failure modes from differing equipment types, etc.). Random failures are best addressed by improved predictive-maintenance programmes (more rigorous condition monitoring).
- 3) Early wear-out failures ($1,0 < \beta < 4,0$) can occur in the normal design life of the equipment and most often include low cycle fatigue, most bearing failures, corrosion and erosion. Preventive maintenance resulting in repair or replacement of critical components can be cost effective. The period for overhaul is read off the Weibull plot at the appropriate β life.
- 4) Old age wear-out failures ($\beta \geq 4,0$) most often occur outside the normal design life. The steeper the slope (β), the smaller the variation in the times to failure and the more predictable the results. Typical failure modes with old age wear include stress corrosion, erosion, material property issues, etc. Preventive maintenance to replace parts that produce significant failures can be cost effective. The period for overhaul is read off the Weibull plot at the appropriate β life.

C.1.12 Safety critical equipment

For some equipment, like safety-critical equipment, more specific definitions for a failure and its consequences can be useful. Some recommendations on this are given in Annex F.

C.2 Availability

C.2.1 Normalized definition

See definition in 3.3.

Note the distinction between the terms availability and reliability;

- availability: item working at a given instant (no matter what has happened before);
- reliability: item working continuously over a whole period of time.

“Availability” characterizes a function that can be interrupted without any problem and “reliability,” a function that cannot be interrupted over a whole period of time.

C.2.2 Mathematics of availability

It is with the mathematical definitions that the situation is clarified. In fact, there are several mathematical expressions for “availability” concepts.

- Pointwise or instantaneous availability, $A(t)$, is the probability that an item is in a state to perform a required function under given conditions at a given instant of time, assuming that the required external resources are provided. (This is the definition given in IEC 61508:2010. See also ISO/TR 12489:2013, 3.1.12)

The instantaneous availability, $A(t)$, at time, t , is given by Formula (C.4):

$$A(t) = P_S(t) \quad (C.4)$$

where $P_S(t)$ is the probability that item S is in a up state at time, t.

- Mean availability for a given mission (over a given period of time), $A_{m(t_1,t_2)}$, is the average of the pointwise availabilities over the time period, from t_1 to t_2 : $t_1 \ll t \ll t_2$. This is given mathematically by Formula (C.5) (see also ISO/TR 12489:2013, 3.1.13):

$$A_{m(t_1,t_2)} = \frac{1}{t_2 - t_1} \int_{t_1}^{t_2} A(t) dt \quad (C.5)$$

- “Steady state” (or asymptotic) availability, A_{as} , is the limit of the mean availability for a given mission when the time period goes to infinity, as given by Formula (C.5) (see also ISO/TR 12489:2013, 3.1.17):

$$A_{as} = \lim_{t \rightarrow \infty} \frac{1}{t} \int A(t) dt \quad (C.6)$$

These definitions show clearly the difference between the various “availabilities,” specifically:

- a) for the pointwise availability, we are interested only in the fact that the item works well when it is required (no matter if it has failed at some previous moment, provided it has been repaired since and has not failed again);
- b) for the mean availability, we are interested in the same, but averaged over a given period of time. This corresponds to the ratio of the effective working time over the whole duration under interest.

Note that in most, but not all, of the cases, after a certain time, the pointwise availability reaches an asymptotic value called “steady state” availability, which is equal to the above “steady state availability”.

EXAMPLE For a simple repairable item with only two reliability parameters [failure rate (λ ; see C.3) and repair rate (μ)], the pointwise availability is equal to Formula (C.7):

$$A(t) = 1 - \frac{\lambda}{\lambda + \mu} \left\{ 1 - \exp \left[-(\lambda + \mu)t \right] \right\} \quad (C.7)$$

When t goes to infinity, we obtain the asymptotic value, as given by Formula (C.8), which is also the steady state availability:

$$A_{as} = \frac{\mu}{\lambda + \mu} \quad (C.8)$$

This availability is the “technical” or “intrinsic” or “inherent” availability of the item (see also C.2.3.2).

C.2.3 Measures and estimates of mean availability data records

C.2.3.1 Mathematics of measures and estimates of mean availability data records

The interest of the availability concept within the application areas of this International Standard is the relationship existing between data collected in the field and the mathematical meaning of the mean availability over a given period.

When planning to collect measures and estimates of mean availability (the term “availability” is defined in Clause 3, see also 7.1.2), two types of mean availability and the sum of the two should be considered.

- a) Operational availability, A_o , is given by Formula (C.9):

$$A_0 = \text{MUT} / (\text{MUT} + \text{MDT}) \quad (\text{C.9})$$

where

MUT is the mean up time, estimated by using the actual up time observed in the field;

MDT is the mean down time, estimated by using the actual up and down times observed in the field.

b) Intrinsic availability, A_I , is given by Formula (C.10):

$$A_I = \text{MTTF} / (\text{MTTF} + \text{MTTRes}) \quad (\text{C.10})$$

where

MTTRes is the mean time to restoration, estimated by using the active maintenance times observed in the fields; see Table 4 and Figure 4;

MTTF is the mean time to failure, estimated by using the actual up times observed in the field.

c) Mean elapsed time between failures, METBF, is given by Formula (C.11):

$$\text{METBF} = \text{MTTF} + \text{MTTRes} \quad (\text{C.11})$$

where MTTF and MTTRes are as defined above.

C.2.3.2 Uses of measures and estimates of mean availability data records

A_I and A_0 are not equivalent, except when MDT is equal to MTTRes. Generally, A_I is of interest to reliability engineers, while A_0 is of interest to maintenance people.

These estimations explain why the unit of availability is expressed as the proportion of time(s) the item is in the up state.

Be aware that though MDT, which is made of several delays (detection, isolation, spare parts, stand-by, repair duration, re-instatement, etc.), and MUT, which is normally close to the MTTF, the operational availability depends on the combined aspects of the reliability performance, the maintenance performance, the maintainability performance and the maintenance support performance. Therefore, this is not an intrinsic property of the item itself but a property of that item within the context (the whole installation, procedures, maintenance policy, etc.) where it is used.

Depending on the interest of the user, only a part of the down time may be considered. Extra delays due to required external resources other than maintenance resources may be excluded from the estimation in order to perform a more intrinsic estimation, such as given in Formula (C.12):

$$A_I = \text{MTTF} / (\text{MTTF} + \text{MTTRes}) \quad (\text{C.12})$$

which is an estimate of the theoretical formula given in Formula (C.13):

$$A_m = \frac{\mu}{\lambda + \mu} \quad (\text{C.13})$$

In the same way, the time spent for preventive maintenance can be included or not in the evaluations.

The above single formula for evaluating the two reliability parameters, λ and μ , is not sufficient. It is necessary to evaluate λ and μ separately based on the observed MTTF (or MUT) for the failure rate, and the observed MTTRes (or MRT, a part of the MDT) for the repair rate.

As the amount of data collected increases, the estimations become closer and closer to the true mathematical values. The uncertainties can be managed through classical statistical analyses.

It is quite common to define the operational availability based on the down time related to the sum of both corrective and preventive maintenance. The term “technical availability” is also sometimes used as an alternative to “intrinsic availability.” In the latter case, down time related to corrective maintenance only shall be included in the calculations. The operational availability per year, $A_{o,y}$, and the technical availability per year, $A_{T,y}$, can then be calculated as given in Formulas (C.14) and (C.15), respectively:

$$A_{o,y} = \frac{8760 - (t_C + t_P)}{8760} \quad (\text{C.14})$$

$$A_{T,y} = \frac{8760 - t_C}{8760} \quad (\text{C.15})$$

where

t_C is the time for corrective maintenance;

t_P is the time for preventive maintenance.

C.3 Failure rate and failure frequency estimations

C.3.1 General

C.3.1.1 Mathematics for failure rate and failure frequency estimation

The “failure rate” is a classical reliability parameter, denoted by the Greek letter, λ (lambda). The failure rate is sometimes linked to the reliability parameter “failure frequency” (or “average failure frequency”), denoted by the letter w and also called the (average) unconditional failure intensity. See definitions of the two terms in Clause 3.

The average failure frequency is an average frequency, w , of failure (i.e. a number of failures per unit of time). It is easy to calculate an estimator, \hat{w} , of this frequency from historical RM data by dividing the number of observed failures, n , of the considered item by its cumulative working time (operational time) during the same period of time, as given by Formula (C.16):

$$\hat{w} = n / \sum TTF_i \quad (\text{C.16})$$

where

n is the number of observed failures;

TTF_i is the i th time to fail (i.e. i th duration of functioning observed from the field).

NOTE 1 w is a function of time t and it asymptotically approaches $1/MTTF$.

In Formula (C.16), TTF_i means the i th “time to fail” (i.e. the i th duration of functioning) observed from the field. So, this is actually the estimator of $1/MTTF$ for a repairable item (component/system). This w is usually a function of time t , but asymptotically it approaches $1/TTF_i$.

In practice, the term $\sum TTF_i$ in Formula (C.16) is often replaced by the total operational time of the units investigated; see the example below.

NOTE 2 Formula (C.16) is true only if an exponential failure distribution (constant hazard rate for the system) is assumed. In case a component does not have constant hazard rate, the asymptotic rate for the system is not reached until after several changes of the component (renewal process). Such an interpretation means that the number of failures over a (long) time period $(0, t)$ “on the average” is equal to $w \times t$. Or, more generally: if a number of items with the same constant average “failure frequency,” w , are observed over a total operational time, t , then the mean number of failures observed over this period asymptotically equals $w \times t$.

EXAMPLE An average failure frequency of 3×10^{-4} failures per hour means that on the average 30 failures will occur during an operational period of 100 000 h. It is emphasized that we are talking here about repairable units, i.e. units that are repaired immediately after failure.

In the above example, we state that in the long run the mean elapsed time between two failures of a unit equals $1/w = 3\,333$ h, which is also equal to the sum of MTTF and MTTRes (valid only for repairable items, and provided the item is as good as new after repair).

=> valid only for repairable items It is important not to confuse this TTF_i of 3 333 h with expected time to failure. Since the average failure frequency is assumed constant, the probability of a failure is the same from 0 h to 100 h, from 3 300 h to 3 400 h and from 9 900 h to 10 000 h.

The term “failure rate” (or Vesely failure rate, see e.g. ISO/TR 12489:2013) is sometimes (e.g. in text books) used synonymously with the term “hazard rate.” Also, this rate is generally a function of time, t , (since the start of operation of the unit). Then, $\lambda(t)dt$ is the probability that the item fails between t and $t + dt$, provided it has been working all over $[0, t]$. This function, $\lambda(t)$, then defines the lifetime distribution of the units (i.e. the statistical distribution of the time to first failure). This distribution can also be expressed in terms of the probability, $F(t)$, that the item will fail before it has been operating a time, t , as given in Formula (C.17):

$$F(t) = 1 - R(t) \tag{C.17}$$

where $R(t)$ is the probability that the item will survive a time period, t .

Nevertheless, it can be demonstrated mathematically that when the hazard rate, $\lambda(t)$, is constant over time, t , then the average failure frequency (w) and failure rate (λ), both have the same estimator as given in Formulas (C.16) and (C.17). In that case, we can use the term “failure rate” without causing too much confusion (but we still have two different interpretations).

The assumption that the failure rate (hazard rate) is constant ($= \lambda$) over the whole life of the concerned item means that the probability of the item to survive a period, t , is given by Formulas (C.18) and (C.19):

$$R(t) = \exp(-\lambda \times t) \tag{C.18}$$

$$F(t) = 1 - \exp(-\lambda \times t) \tag{C.19}$$

In this case, $\lambda = 1/MTTF$.

C.3.1.2 Uses of failure rate and failure frequency estimation

In the general situation, the hazard rate, $\lambda(t)$, of the item’s lifetime is often assumed to reflect three periods: early failures, useful life and wear-out failures (see Figure C.1). During the early failure period, the $\lambda(t)$ is normally decreasing, during the useful life it is more or less constant and during the wear-out period it is increasing, i.e. the curve, $\lambda(t)$, has the so-called bathtub form (see Figure C.1).

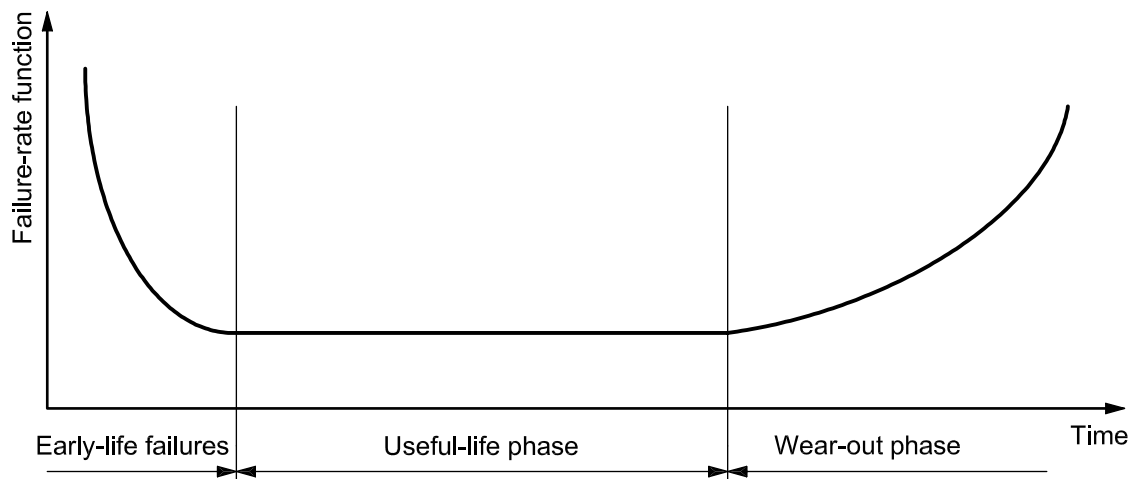

Figure C.1 — Bathtub curve for hazard rate (“failure rate”) of a unit

If early failures are treated separately and units are taken out of service before they arrive at wear-out, the assumption of constant hazard rate can be reasonable. This estimator gives no information on the form of the hazard-rate curve. Assuming that the hazard rate is constant, this is also an estimator for the constant hazard rate. If a constant hazard rate is assumed where wear-out failures are present in the components or spare parts, the reliability is underestimated for low operating time and overestimated for high operating time. With regards to the time to first failure, TFF, the constant hazard rate estimate is totally misleading. Nevertheless, a more sophisticated statistical analysis can be performed to determine if the hazard rate is decreasing, constant or increasing and to evaluate the parameters with another reliability model such as Weibull for components or the Power law for repaired systems.

In that case, it is necessary to take into consideration the various durations of the TFFs.

The standard methods for estimation of a constant failure rate based on the observed number of failures over a given time of operation are described in C.3.2 and C.3.3.

C.3.2 Estimation of failure rate

C.3.2.1 Maximum likelihood estimator of a constant failure rate

The maximum likelihood estimator, $\hat{\lambda}$, of λ is given by Formula (C.20):

$$\hat{\lambda} = \frac{n}{\tau} \quad (\text{C.20})$$

where

n is the number of failures observed;

τ is the aggregated time in service, measured either as surveillance time or operating time.

Note that this approach is valid only in the following situations:

- The number of failures for a specified number of items with the same constant failure rate, λ , are available for a given aggregated time, τ , in service;
- At least one failure is observed ($n \geq 1$) over time, τ .

In “classical” statistical theory, the uncertainty of the estimate may be presented as a 90 % confidence interval with a lower limit, L_{Lower} , and an upper limit, L_{Upper} , as given by Formulas (C.21) and (C.22), respectively:

$$L_{Lower} = \frac{1}{2\tau} z_{0,95;\nu} \tag{C.21}$$

$$L_{Upper} = \frac{1}{2\tau} z_{0,05;\nu} \tag{C.22}$$

where

$z_{0,95;\nu}$ is the upper 95th percentile of the χ^2 -distribution (chi-square) with ν degrees of freedom;

$z_{0,05;\nu}$ is the lower 5th percentile of the χ^2 -distribution (chi-square) with ν degrees of freedom.

NOTE 1 The chi-square distribution can be found in most textbooks on statistics or in e.g. SINTEF (2009).

NOTE 2 Other confidence limits can also be used depending on application.

EXAMPLE Assume that $n = 6$ failures have been observed during an aggregated time in service $\tau = 10\,000$ hours. The failure rate estimate, $\hat{\lambda}$, expressed as failures per hour as given in Formula (C.20), is calculated as

$$\hat{\lambda} = \frac{n}{\tau} = 6 \cdot 10^{-4}$$

The 95 % confidence interval, from Formulas (C.21) and (C.22), is calculated as

$$\left[\frac{1}{2\tau} z_{0,95;2N}, \frac{1}{2\tau} z_{0,05;2(N+1)} \right] = \left(\frac{1}{20\,000} z_{0,95;12}, \frac{1}{20\,000} z_{0,05;14} \right) = \left(2,6 \cdot 10^{-4}, 11,8 \cdot 10^{-4} \right)$$

The estimate and the confidence intervals are illustrated in Figure C.2.

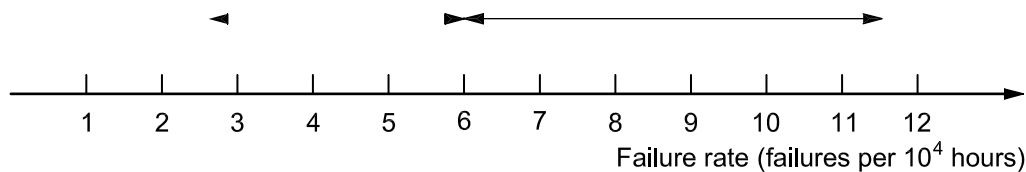

Figure C.2 — Estimate and 95 % confidence interval for the example calculation of the failure rate

C.3.2.2 Estimators and confidence intervals for a heterogeneous sample

Most of the time, a sample is constituted of items which come from different installations with different operational and environmental. We are here dealing with heterogeneous data, corresponding to different kind of equipment.

Such data are clustered into k classes, which are assumed to be homogeneous. So, a heterogeneous sample is the combination of several more or less homogeneous samples.

Starting from data assumed to be clustered into k (homogeneous) classes, each class is represented by some index i with $i = 1, \dots, k$ in the following. For the i^{th} class, the following data is assumed available:

- the class size m_i , which stands for the number of equipment in the i^{th} class,
- the total number n_i of failures for all the equipment of the i^{th} class,
- the cumulated operational time τ_i for all the equipment of the i^{th} class.

In order the failure rate estimate $\hat{\lambda}_i$ to take into account the data of all classes (n_i, t_i) $1 \leq i \leq k$ (and not only (n_i, t_i)), a Bayesian approach is next proposed. The variation of the failure rate between classes may be modelled by assuming that the failure rate is a random variable with some distribution given by a probability density function $\pi(\lambda)$.

The mean failure rate is then:

$$\theta = \int_0^{\infty} \lambda \cdot \pi(\lambda) d\lambda \quad (C.23)$$

And the variance is:

$$\sigma^2 = \int_0^{\infty} (\lambda - \theta)^2 \cdot \pi(\lambda) d\lambda \quad (C.24)$$

The following procedure is used to calculate the heterogeneous estimator $\hat{\lambda}$:

a) Calculate \bar{m} , S_1 , S_2 , \bar{V} , V^* , μ and \tilde{V} as follows:

$$\bar{m} = \frac{\sum_{i=1}^k n_i}{\sum_{i=1}^k \tau_i}, \quad (C.25)$$

$$S_1 = \sum_{i=1}^k \tau_i, \quad (C.26)$$

$$S_2 = \sum_{i=1}^k \tau_i^2, \quad (C.27)$$

$$\bar{V} = \sum_{i=1}^k \frac{(n_i - \bar{m}\tau_i)^2}{\tau_i}, \quad (C.28)$$

$$V^* = (\bar{V} - (k-1)\bar{m}) \frac{S_1}{S_1^2 - S_2}, \quad (C.29)$$

$$\mu = \frac{1}{k} \sum_{i=1}^k \frac{n_i}{\tau_i}, \quad (C.30)$$

$$\tilde{V} = \frac{1}{k-1} \sum_{i=1}^k \left(\frac{n_i}{\tau_i} - \mu \right)^2, \quad (C.31)$$

b) Derive to compute \hat{E}_t and \hat{V}_t :

$$\hat{V}_t = \max \{ V^*, \tilde{V} \} \quad (C.32)$$

$$\hat{E}_t = \frac{1}{\sum_{i=1}^k \frac{1}{\frac{\hat{m}}{\tau_i} + \hat{V}_t}} \sum_{i=1}^k \frac{1}{\frac{\hat{m}}{\tau_i} + \hat{V}_t} \frac{n_i}{\tau_i} \tag{C.33}$$

c) Estimates for $(\hat{\alpha}, \hat{\beta})$ are next derived through:

$$\hat{\beta} = \frac{\hat{E}_t}{\hat{V}_t}, \tag{C.34}$$

$$\hat{\alpha} = \hat{\beta} \hat{E}_t \tag{C.35}$$

d) So, the global estimate for $\hat{\lambda}_i$ can be expressed as follows:

$$\hat{\lambda}_i = \frac{\hat{\alpha} + n_i}{\hat{\beta} + \tau_i} \tag{C.36}$$

Taking $\varepsilon \in \left[0, \frac{1}{2}\right]$, an approximate credibility interval with level $1-\varepsilon$ for λ_i is

$$\left[q_{\hat{\alpha}+n_i, \hat{\beta}+\tau_i}^{\Gamma} \left(\frac{\varepsilon}{2} \right); q_{\hat{\alpha}+n_i, \hat{\beta}+\tau_i}^{\Gamma} \left(1 - \frac{\varepsilon}{2} \right) \right]$$

Or, equivalently

$$\left[\frac{q_{\hat{\alpha}+n_i, 1/2}^{\Gamma} \left(\frac{\varepsilon}{2} \right)}{2(\hat{\beta} + \tau_i)}; \frac{q_{\hat{\alpha}+n_i, 1/2}^{\Gamma} \left(1 - \frac{\varepsilon}{2} \right)}{2(\hat{\beta} + \tau_i)} \right]$$

C.3.3 Estimation of failure rate with zero failures — Bayesian approach

C.3.3.1 General

NOTE The Bayesian approach is not always accepted by safety authorities (e.g. in the nuclear field).

The classical approach described above has difficulties when the observed number of failures is zero. An alternative approach which handles the situation with zero failures is to use a Bayesian approach with non-informative prior distribution. When n failures have been observed during time, t , the failure rate estimate, $\hat{\lambda}$, in the posteriori distribution is given by Formula (C.37):

$$\hat{\lambda} = \frac{2n + 1}{2t} \tag{C.37}$$

which, in the case with zero failures, reduces to Formula (C.38):

$$\hat{\lambda} = \frac{1}{2t} \tag{C.38}$$

C.3.3.2 Constant confidence-level estimator

The failure rate is estimated from Formula (C.39):

$$\hat{\lambda} = \frac{n + 0,7}{t} \quad (\text{C.39})$$

C.3.3.3 Advantages

The advantages of this estimator are the following:

- it works in the zero failure case;
- it is homogeneous from a confidence level point of view;
- the estimator of the median value converge toward the maximum likelihood estimate when n increases;
- it is easy to use.

In addition caution should however be given to the use of the above mentioned estimators with respect to whether they are used for individual failure modes or total failure rate, including all failure modes

C.3.4 Failure as function of cycles rather than time

For some equipment, failure modes or in certain conditions, it is a more realistic model to regard the probability of failure as a function of the number of operations or cycles, rather than time. This model should be considered when it is presumed that the number of operations is a more likely contributor to failure than the actual time. For instance, a connector is presumably much more prone to failure, if it is connected and disconnected very frequently, rather than connected once and staying that way for many years. Consequently, the time is not the major factor, but rather the number of operations. In this case, all of the principles and formulas in the previous sub-clauses still apply, except that the 't' denoting the time is replaced by e.g. a 'c', denoting the number of cycles. Regarding the use of cycles for reliability purposes, see also IEC 61810-2:2011.

Note that if the number of cycles is approximately constant in time, this alternative model can be approximated by a probability of failure as a function of the time, but this is rarely the case when failure rates (or average failure frequency) are based on data collected across different installations, geographical locations etc. with different operating conditions. Note also that an equipment class may be split in terms of failure rate model for different failure mechanisms or causes, as the time-based model may be more relevant for some (e.g. corrosion) and the cycle-based model may be more relevant for others (e.g. wear).

When performing analyses on a higher taxonomic (hierarchical) level, however, one needs to be careful with the use of the cycle-based model. The installation, plant or system performance is best expressed by a time-based model, since it is not meaningful to talk about number of cycles of an entire installation. In this case, the cycle-based models used for some equipment or failure modes needs to be converted to a time-based model. This is done by the simple formula

$$\text{MTTF} = \text{MCTF} / \xi \quad (\text{C.40})$$

where ξ is the expected number of cycles per time unit. It is, however, important to use the model on the right hand side of the formula, since it will respond to possible changes in the expected number of cycles. See also definition of mean number of cycles in 3.58.

Since 'cycles' is the most common term in this regard, it has also been used here. It can, however, be replaced by the term, 'demand', which is explained in C.1.3. The collected information on demands can thus be used to calculate the MCTF, which can be interpreted as mean start-ups to failure, mean activations to failure, etc., depending on the equipment. The Mean Cycles To failure (MCTF) is defined in 3.57.

A relevant example can be found in ISO/TR 12489:2013, 3.2.13 (Example 2).

It should be noted that some failure modes are related to demands, like e.g. “Failure to start/stop/open/close/connect/disconnect on demand”. Equipment classes where such failure modes are relevant may be considered as subjects to analyses with cycle or demand based models, rather than time based models. However, the occurrence of the failure mode alone is not enough to determine which model is better. A valve failure may have been recorded with the failure mode “Failure to open on demand”. In this case, one possibility is that it failed to open due to demand, because opening the valve frequently in the past has induced gradual wear until it fails. Another possibility is that it has not been opened frequently in the past and corroded over time in closed position. Upon opening, a hidden failure is detected.

These two scenarios are very different, but will typically be denoted with the same Failure mode and the same Detection method (on demand). The difference between failure on demand and due to demand in this case is only seen by the different failure mechanisms, which are wear and corrosion, respectively. Depending on which is the dominant failure mechanism, the valve reliability is expressed in terms of either time or number of cycles in this case.

In general, Drilling, Well completion and Well intervention equipment are by nature more demand dependent than time dependent. Other equipment classes in that category may include Cranes, Loading arms, Winches, Mixers and possibly Valves as mentioned above.

C.4 Maintainability

C.4.1 General

Several normalized definitions of the concept of “maintainability” exist in normalization documents (see also 3.47), specifically

- ability, under given conditions, of an item to be maintained in or restored to, over a given period of time, a state where it is able to perform its function when the maintenance is achieved under prescribed conditions, procedures and means;
- measure of the ability of an item to be maintained in or restored in specified conditions when the maintenance is achieved by personnel with a specified level of skill and using prescribed procedures and resources at all the prescribed levels of maintenance and repair.

C.4.2 Mathematical meaning

C.4.2.1 Maintainability concepts

There is a probabilistic version of “maintainability”, similar to that for the concepts of reliability and availability, as follows:

probability that an item can be restored to a condition within a prescribed period of time when maintenance is performed by personnel having specific skill levels using prescribed procedures and resources.

See also C.5.5.2 regarding the use of downtime terms normally related to corrective maintenance time, i.e. mean time to restoration (MTTRes) and mean overall repairing time (MRT).

C.4.2.2 Maintainability performance

This is a probability method to measure maintainability performance, in addition to many other indicators.

The maintainability, $M(t)$, can be expressed by Formula (C.41):

$$M(t) = P(\text{RT} \leq t) \quad (\text{C.41})$$

where

RT is the active time to repair item S, i.e. the time from failure detection to restoration;

$P(\text{RT} \leq t)$ is the probability that RT is less than time t .

Therefore, $M(t)$ is the cumulative distribution function (CDF) of the RTs of item S. By definition of the CDFs, $M(t)$ is a non-decreasing function varying from 0 to 1 as t varies from 0 to infinity. That means any repairable item is likely to be repaired (restored) if we wait long enough.

As a property of the CDF, it is possible to express $M(t)$ by using the “hazard rate” of the distribution, which, in this case, is the so-called “repair rate” $\mu(t)$.

When this rate is constant, we obtain the classical formula for the maintainability, $M(t)$, given in Formula (C.42):

$$M(t) = 1 - \exp(-\mu \cdot t) \quad (\text{C.42})$$

where μ is the so-called repair rate, which is equivalent to the hazard rate and which is designated MTTRes .

Note that, depending on what we actually want to evaluate, the whole down time, a part of it or only the active maintenance time can be used as RT in Formula (C.41).

C.4.2.3 Repair rate

The repair rate, μ , is a reliability parameter that allows the evaluation of the probability that the item is repaired within a certain delay after having failed (this is the probabilistic version of the “maintainability” of the item).

This parameter plays a role for the TR (time to repair) analogous to that of the failure rate for the TTF (time to failure).

The estimate is given by Formula (C.43):

$$\mu = \frac{n}{\sum \text{RT}_i} = \frac{1}{\text{MRT}} \quad (\text{C.43})$$

where

n is the number of repairs;

RT_i is the length of the i th repair

MRT is the mean overall repairing time.

All data can be collected from the field.

This parameter can be used to evaluate the maintainability of the item using an exponential law as given in Formula (C.44):

$$M(t) = 1 - \exp(-\mu \cdot t) \quad (\text{C.44})$$

More sophisticated probabilistic laws are often used for modelling repairs. In these cases, the repair rate becomes a non-constant $\mu(t)$ and the simple estimate in Formula (C.44) no longer applies. For example, it is necessary to take into consideration the length of the various RT_is in order to evaluate the parameter of a log-normal law.

C.4.2.4 Measures and estimates

An indicator of the maintainability performance is the MRT (mean overall repairing time) of the concerned item. This MRT is the part of the mean down time (MDT) due to the repair itself. It can be estimated from the sum of the observed “times to repair” (from data feedback) divided by the number of repairs, as given in Formula (C.45):

$$\widehat{\text{MRT}} = \sum \frac{\text{RT}_i}{n} \quad (\text{C.45})$$

NOTE When the analytical form of $M(t)$ is known or has been chosen, a link can be made between the parameters of the exponential law and the MRTs estimated from the field.

The estimation in the classical case, when Formula (C.44) holds and when μ , the so-called “repair rate,” is constant, is easy. As the amount of data collected increases, the estimation becomes closer and closer to the true mathematical values. The uncertainties can be managed through classical statistical analyses.

For more complicated repair laws (e.g. log-normal), it is necessary to take into consideration the length of the various observed TTFs and to do a statistical fitting.

When planning to collect data (see 7.1.2), it is necessary to consider the various methods of recording down times (see Table 4 in this International Standards, and also Figures 5 to 7 in ISO/TR 12489:2013) and the appropriate parts of the down time to be included need to be chosen. Depending on what is done, several parts of the down time can be included within the MRT.

C.4.3 Maintainability — Intrinsic and extrinsic factors

For comparison purposes, it is important to identify what is intrinsic (only related to the item) and extrinsic (context-dependent) in the maintainability of single items.

- Intrinsic maintainability considers only the built-in characteristics designed to help the maintenance of an item.
- Extrinsic maintainability considers all that is context-dependent: logistics, support, task organisation, isolation, de-isolation.

“Extrinsic” maintainability changes from site to site while “intrinsic” maintainability does not. For reliability studies, it is very important to be able to analyse and model separately these two definitions of the maintainability.

For comparison purposes, it is useful to be able to identify those factors of maintainability that relate only to the item itself, e.g. lubrication or ease of dismantling, which can be called intrinsic maintainability, and those related to its location, e.g. logistics, support, task organisation, isolation, de-isolation, which can be called extrinsic maintainability.

C.4.4 Procedure for compiling data records for maintainability

When planning to collect measures and estimates of failure maintainability (see 7.1.2), choose appropriate measures from C.5 for the information required.

C.5 “Mean time” interpretations

C.5.1 Principle

The mean time during which the item is in certain states can be measured by use of mean down time, mean time between failures, mean time to failure, mean time to repair, mean up time, etc. Mean values are a good approximation when limited data are available or when there is no clear trend in the data. However, if there is a trend, as there often is, in maintenance data, e.g. increasing hazard rate (wear-out) or decreasing hazard rate (“run in”), mean values can be misleading and can result in incorrect decisions.

C.5.2 Mean down time (MDT)

Mean down time is formulated as the mean time during which the item is in its down state. See definition of down state in 3.15.

This includes all the delays between the failure and the restoration of the function of the concerned item: detection, spare parts, logistics, stand-by, maintenance policy, active maintenance time, re-instatement, etc.

This is not an intrinsic parameter, as it depends on the context within which the item is used.

Therefore, only a specific part of this down time can be of interest to an analyst performing a reliability study (i.e. MTTRes). See also Figure 4 in this International Standard, and also Figure 5 to 7 in ISO/TR 12489:2013.

C.5.3 Mean elapsed time between failures (METBF)

See definition in 3.60.

C.5.3.1 Mathematics of METBF

The general expression for the mean elapsed time between failures, METBF, can be expressed as given in Formula (C.46):

$$\text{METBF} = \text{MUT} + \text{MDT} \quad (\text{C.46})$$

where

MUT

is the mean up time;

MDT

is the mean down time.

which, in simple cases, can be expressed as given in Formula (C.47):

$$\text{METBF} = \text{MTTF} + \text{MTTRes} \quad (\text{C.47})$$

where

MTTF is the mean time to failure;

MTTRes is the mean time to restoration.

Like the MDT, this is not an intrinsic parameter, but depends on the context within which the item is used.

C.5.3.2 Uses for METBF

METBFs are calculated and used for different purposes (for item and equipment, service, site, etc.). The “item” and “equipment” are of interest mainly to reliability engineers and the others to the maintenance people.

C.5.4 Mean time to failure (MTTF)

See definition in 3.62.

C.5.4.1 Mathematics of MTTF

This parameter, mean time to fail, MTTF, is linked to the failure rate, λ , of the concerned item by Formula (C.48):

$$\text{MTTF} = 1 / \lambda \quad (\text{C.48})$$

where λ is the failure rate, and is valid only for constant failure rates.

C.5.4.2 Use of MTTF

Rigorously, this parameter concerns only the first failure of a new item before any maintenance task has been performed. If the repair is perfect, i.e. the repaired item is “as good as new”, MTTF is exactly the same as MUT.

Take care to understand this term and be aware that in practice, MTTF and MUT are often confused (see definition of MUT). See also definitions of failure frequency and failure rate (in Clause 3), which are similar terms often used to describe the occurrence of failures.

NOTE MTTF is normally associated with the assumption of an exponential distribution (e.g. a constant hazard rate). MTTF is also used for other distributions as, for example, the normal distribution or the Weibull distribution. Formulas (C.46) to (C.48) are valid only for the assumption of an exponential distribution for both METBF and MTTF. Further, it is a prerequisite that all the time is measured in the same time dimension (global or local time).

C.5.5 Mean overall repairing time (MRT)

See definitions of the mean overall repairing time (MRT) in 3.61.

C.5.5.1 Mathematics of MRT

This parameter, mean overall repairing time, MRT, is linked to the repair rate, μ , of the concerned item by Formula (C.49):

$$\text{MRT} = 1 / \mu \quad (\text{C.49})$$

Where μ is the repair rate.

C.5.5.2 Uses of MRT

The name MRT is generally related only to the active corrective maintenance time that is a part of the down time, but depending on the study, it can range from the active corrective maintenance time to the whole down time. In that case “restoration” can be used instead of “repair”. In the general case, however, “down time” is greater than “active maintenance time”. See also in ISO/TR 12489:2013, Figure 5, and 3.1.31 (Mean time to repair; MTTR), 3.1.32 (mean time to restoration; MTTRes), 3.1.33 (mean overall repairing time; MRT) and 3.1.34 (mean active repair time; MART).

If preventive maintenance is also included in addition to the corrective maintenance (repair) dealt with above, the mean time to maintain, MTTM, expressed in hours, can be calculated as given in Formula (C.50):

$$\text{MTTM} = \frac{(t_{mc} \cdot M_c) + (t_{mp} \cdot M_p)}{(M_c + M_p)} \quad (\text{C.50})$$

where

t_{mc} is the total elapsed corrective maintenance or repair time, expressed in calendar hours;

t_{mp} is the total elapsed preventive maintenance time, expressed in calendar hours;

M_c is the total number of corrective maintenance actions (repairs);

M_p is the total number of preventive maintenance actions.

C.5.6 Mean up time (MUT)

If repairs are “perfect”, i.e. the repaired item is “as good as new,” Mean up time (MUT) is exactly the same as MTTF. If repair is not perfect, or for equipment comprised of parts that have been repaired and others that have never failed, MUT and MTTF are two different parameters (see also C.5.4).

C.5.7 Procedure for compiling data records for mean time

When planning to collect measures and estimates of mean time (see 7.1.2), choose appropriate measures from C.5 for the information.

C.6 Testing for hidden failures in safety systems

C.6.1 General principles

There are two different principles that can be used to establish the necessary test interval for a safety function with hidden failures:

- required availability

This approach is based on a risk analysis for which some absolute risk acceptance criteria have been established. Each safety function of a plant/system/item of equipment is allocated reliability

requirements based on this. This approach is in line with the standards IEC 61508:2010 (all parts) and IEC 61511:2016 (all parts).

— cost-benefit availability

Under some circumstances, the consequence of a safety-system failure in a hazardous situation can be reduced to economic consequences only. It is, then, appropriate to establish the preventive maintenance programme by optimizing the total costs by weighing the cost of preventive maintenance against the cost of safety-system failure; see ISO 15663:2000/2001 (all parts).

There is a need to collect data with regards to both failures occurred before the test (true hidden failures), and those failures occurring because of the test (e.g. cycle failure, human error, unavailability during test).

C.6.2 Required availability

This situation is characterized by an upper limit, L_{PFD} , that the average probability of hidden failure observed on demand is not allowed to exceed. The necessary test interval, τ , to achieve this can be found by the approximation in Formula (C.51). This formula assumes that test have no detrimental effects ($\gamma=0$) and that MRT is negligible.

$$\tau = \frac{2L_{\text{PFD}}}{\lambda} \tag{C.51}$$

where

L_{PFD} is the upper accepted limit for average probability of failure on demand;

λ is the failure rate for on-demand failures.

The average probability of failure on demand can be calculated from Formula (C.52):

$$\text{PDF}_{\text{avg}} = \lambda \frac{\tau}{2} + \frac{\lambda}{\mu} + \frac{\gamma}{\mu\tau} \tag{C.52}$$

where

γ is the cycle failure rate;

τ is the test interval time;

μ is the repair rate.

The optimal test interval τ_{opt} can then be calculated as:

$$\tau_{\text{opt}} = \sqrt{2\gamma / (\lambda \cdot \mu)} \tag{C.53}$$

See ISO/TR 12489:2013 (e.g. 3.1.16) for further details on availability calculations.

C.6.3 Mathematics of cost-benefit availability

When we use the term cost-benefit availability, we are considering a safety system classified as SIL 1 as defined in IEC 61508:2010 (all parts). This means that there are no absolute requirements with respect to the availability of the system. Still, this can be an important protective system with respect to potential economic loss. An example is a vibration trip on a pump that is supposed to stop the pump if the vibration exceeds a defined level. If the vibration trip fails, the material damage to the pump can be significant. The approach to use in such a situation is to perform an economic optimization where the cost of testing is weighed against the expected cost related to failures.

Mathematically, this idea can be formulated by the approximation in Formula (C.54) for total expected cost:

$$E(C_T) = \frac{1}{2} \lambda_{fto} \cdot \tau \cdot f \cdot \frac{C_m}{\tau} \quad (C.54)$$

where

$E(C_T)$ is the total expected cost;

λ_{fto} is the average failure rate for failure mode “fail to operate”;

f is the frequency of events when the safety system is supposed to be activated;

C_m is the cost of each preventive maintenance activity or test;

τ is the test interval;

EXAMPLE For a fire alarm, f is the frequency of fires.

C_f is the difference in cost between the consequences of the hazardous situation when the safety system works and when it does not work;

EXAMPLE For an automatic fire-extinguishing system, C_f is the difference in damage if the extinguishing system is automatically activated or not in case of a fire. In many cases, it is required to perform a coarse risk analysis to estimate C_f . In the case of a fire, for instance, one important aspect to evaluate is the probability of people being present to discover the fire and being able to manually activate the fire extinguishing equipment).

The economic optimal test interval may be found by finding the derivative of the total expected cost and setting it equal to zero as given in Formula (C.55):

$$\tau = \sqrt{2C_m / (\lambda_{fto} \cdot f \cdot C_f)} \quad (C.55)$$

where the parameters are the same as those for Formula (C.54).

The cost of the shutdown of the installation when a failure is detected by a test should be also considered. The cost of shutdown due to spurious failure may be also considered.

C.6.4 Handling of uncertainty

The uncertainty related to the predicted reliability and availability values should be discussed, and if possible, quantified. The quantification may have the form of an uncertainty distribution for the expected value of the performance measure or a measure of the spread of this distribution (e.g. standard deviation, prediction interval).

The main factors causing variability (and hence stochastic uncertainty in the predictions) should be identified and discussed. Also, factors contributing to the uncertainty as a result of the way the reliability performance is modelled should be covered, including relevant assumptions made (cf. e.g. Selvik and Aven, 2011).

Importance and sensitivity analyses may be carried out to describe the sensitivity of the input data used and the assumptions made.

For further guidance regarding numerical uncertainties handling, see ISO/TR 12489:2013, Annex O.

C.6.5 Testing during manufacturing or qualification testing

Testing during manufacturing or qualification testing (reliability testing or accelerated testing) will have a need for various statistical analyses, for e.g. estimating failure rates (or failure frequency). ISO 20815:2008, Annex I.9 and IEC 61164:2004 give further information.

C.7 Human error as an underlying contributor to equipment performance

Human behaviour has both a positive and negative effect on equipment performance. The tendency is, however, to focus on the negative effect and to call it human error. Clause 3 Terms and definitions defines both error and human error (cf. e.g. Kirwan, 1994) as a discrepancy, the first in relation to an object's true and measured condition and the second in relation to a human's intended behaviour (and expected outcome) and actual behaviour (and actual outcome). However, throughout this document the term "error" always appears in combination with a number of words which each give more specificity to its meaning. These combinations with "error" include:

- human (3.22, 3.36, Table B.3, C.1.10, C.6);
- computing (3.22);
- software (3.22, 3.87, Table B.2);
- operating (3.37, Table B.1);
- calibration (Table B.2);
- fabrication (Table B.3);
- installation (Table B.3, C.1.6);
- maintenance (Table B.3);
- documentation (Table B.3);
- management (Table B.3);
- design (B.2.3.2, C.1.6);
- control and monitoring (C.1.8);
- computational (C.1.11).

In all these cases this could be a human error (e.g. management error, operating error, maintenance error) as in Table B.3 or due to human error as an underlying cause when the error is the equipment failure mechanism (e.g. calibration error in Table B.2). Human error as an underlying cause of an equipment failure can always be considered as a possibility.

The causes of human error itself can be numerous. See ISO/TR 12489:2013 for consideration of Human factors in relation to human functions, tasks, performance, types of error, error modelling and quantification (Section 5.5 and Annex H). ISO/TR 12489:2013 deals primarily with random human errors (see the failure classification in Figure B.5).

Annex D (informative)

Typical requirements for data

D.1 General

There are different areas of application of RM data and it is necessary to consider carefully the collection of data (see Clause 7) so that the types of data are consistent with the intended purpose. The types of analyses considered are listed in Table D.1, which also refers to other relevant international and industry standards.

Table D.1 — Areas of application and types of analyses

Areas of application	Type of analysis to be applied	Abbreviation	Supported by ISO 14224	Reference
Safety	A1 — Quantitative risk analysis	QRA	Yes	NORSOK Z-013 ISO 17776 IEC 31010
	A2 — Risk-based inspection	RBI	Yes	API RP 580
	A3 — Safety integrity level	SIL	Yes	IEC 61508 (all parts) IEC 61511 (all parts) ISO/TR 12489
	A4 — Environmental- and social-impact assessment	ESIA	Yes	ISO 14001
LCC/Optimization/Maintenance	B1 — Life cycle cost	LCC	Yes	IEC 60300-3-3 ISO 15663 (all parts)
	B2 — Production availability	PA	Yes	ISO 20815
	B3 — Availability analysis	AA	Yes	ISO 20815
	B4 — Reliability-centred maintenance	RCM	Yes	IEC 60300-3-11 NORSOK Z-008 SAE JA1011 SAE JA1012
	B5 — Spare-parts analysis	SPA	Yes	IEC 60300-3-12 IEC 60300-3-14
	B6 — Failure mode, effect and criticality analysis	FMECA	Yes	IEC 60812
	B7 — Statistical reliability data analysis	SDA	Yes	IEC 60300-3-1 IEC 60706-3
	B8 — Structural reliability	STR	Yes	ISO 19900 NORSOK N-001
	B9 — Root cause analysis	RCA	Yes	IEC 62740

Table D.1 (continued)

Areas of application	Type of analysis to be applied	Abbreviation	Supported by ISO 14224	Reference
General	C1 — Manning-resource planning	MRP	Yes	NORSOK Z-008
	C2 — Six sigma	6 Σ	Partly	ISO 13053
	C3 — Fault tree analysis	FTA	Yes	IEC 61025
	C4 — Markov process analysis	MPA	Yes	IEC 61165
	C5 — Petri Net for Monte Carlo analysis	PNA	Yes	IEC 62551

D.2 Business value of data collection

During the different phases of a development project from concept selection to the operational phase, it is necessary to make a lot of decisions. Many of these decisions are supported by the analysis types listed in Table D.1. These decisions normally have large impact on the project economy and safety, and they should be based on good models and high quality data in order to reach the “best” decisions. Examples of areas where such decisions are taken are shown in Clause 6.

D.3 Data requirements

During development of the second edition of this International Standard, a GAP analysis was performed to reveal the requirements for data in various types of RAMS analysis. The tables below show a summary of the GAP analyses identifying the required data to be recorded for each analysis type. The data requirements have been prioritized by each analyst using the following scores:

- a) normally needed; rated as 1 in Tables D.2 to D.4;
- b) needed optionally; rated as 2 in Tables D.2 to D.4.

A shaded row indicates parameters for which data are already covered in this International Standard. Non-shaded rows indicate parameters identified by the GAP-analyses as possible new parameters to be included in future revisions of this International Standard.

Some recommended parameters (e.g. average failure frequency or failure rate) cannot be recorded directly, but are required to be calculated from other data. These have been termed “derived reliability parameters” (see Annex C).

The data elements in Tables D.2 and D.4 should be seen in conjunction with data elements shown in Tables 5, 6 and 8.

D.4 Description of the analyses

A summary of analyses and relevant standards is given in ISO 20815:2008.

Table D.2 — Equipment data to be recorded

Data to be recorded ^a	Type of analysis to be applied to the data recorded																		Comments
	A1	A2	A3	A4	B1	B2	B3	B4	B5	B6	B7	B8	B9	C1	C2	C3	C4	C5	
	QRA	RBI	SIL	ESIA	LCC	PA	AA	RCM	SPA	FME	SDA	STR	RCA	MRP	6Σ	FTA	MPA	PNA	
Equipment location	1	1	2	1	1	1	1	1	1	1	1	1	1	2	1	2	2	2	Corresponds to equipment attributes (equipment tag number) in Table 5
Classification	1	1	2	1	1	2	1	1	1	1	1	1	1	1	1	2	2	2	Corresponds to classification (equipment class, equipment type and system) in Table 5
Installation data	1	1	2	2	1	1	1	1	1	1	1	1	1	2	1	2	2	2	Corresponds to various classification data elements in Table 5
Manufacturer's data	1	2	1	2	2	1	2	1	1	2	1	1	1	2	1	2	2	2	Corresponds to equipment attributes (manufacturer name and model designation) in Table 5
Design characteristics	1	2	2	2	2	1	2	1	1	2	1	1	1	2	1	2	2	2	—
Surveillance period	1	1	2	1	1	1	1	1	1	1	1	1	2	2	1	1	2	2	—
Accumulated operating period	1	1	2	1	1	1	1	1	1	1	1	1	2	2	1	1	2	2	—
Number of demands	1	1	1	2	1	1	1	1	1	1	1	2	2	2	1	1	2	2	—
Operating mode	1	1	2	1	1	1	1	1	1	1	1	2	2	2	1	1	2	2	—
Common cause failure rate (frequency)	2	2	1	2	2	2	2	2	2	2	2	2	2	2	2	1	2	2	Derived parameter; can be estimated by extracting data with failure cause "Common cause", see Table B.3
Confidence intervals	2	2	2	2	2	2	2	2	2	2	2	2	2	2	2	2	2	2	Derived parameters; see Annex C
Set of spare parts	2	2	2	2	2	2	2	2	1	2	2	2	2	2	2	2	2	2	

^a For definition of codes/abbreviations A1, QRA, etc., see Table D.1.

Table D.3 — Failure data to be recorded

Data to be recorded ^a	Type of analysis to be applied to the data recorded																		Comments
	A1	A2	A3	A4	B1	B2	B3	B4	B5	B6	B7	B8	B9	C1	C2	C3	C4	C5	
	QRA	RBI	SIL	ESIA	LCC	PA	AA	RCM	SPA	FME	SDA	STR	RCA	MRP	6Σ	FTA	MPA	PNA	
Equipment unit	1	2	2	2	1	1	1	1	1	1	1	1	1	1	1	2	2	2	The equipment unit, subunit and MI/component reflect the failed equipment at these levels
Subunit	2	2	2	2	1	2	1	1	1	1	1	2	1	1	2	2	2	2	—
Maintainable item	2	2	2	2	2	2	1	1	1	1	1	2	1	1	2	2	2	2	—
Failure mode	1	2	2	1	2	1	1	1	1	1	1	1	1	1	1	1	1	1	—
Failure impact on equipment function	1	2	2	2	2	1	1	1	1	1	2	1	1	1	2	2	2	2	—
Failure mechanism	2	2	2	2	2	1	2	1	1	1	2	2	1	1	1	2	2	2	—
Failure cause	2	2	1	2	2	1	2	1	1	1	2	1	1	2	2	2	2	2	—
Detection method	1	2	2	2	2	2	2	2	2	1	2	2	1	2	2	2	2	2	—
Failure impact on plant operation	2	2	2	1	1	1	1	1	2	1	2	1	1	1	1	2	2	2	"
Failure date	2	2	1	1	2	2	2	2	2	2	1	1	1	2	2	2	2	2	Essential parameter for all lifetime analyses, e.g. TTT-plot Weibull, etc. Not recommended to discard.
External leakage rate	1	2	2	1	2	2	2	2	2	2	2	2	2	2	2	2	2	2	Hole sizes and leakage volumes may be additional data requirements in QRA, and interfaces/ traceability between accidental event databases and RM databases can be beneficial in some cases.
Failure rate (frequency)	2	2	2	2	2	2	2	2	2	2	2	2	2	2	2	1	1	2	Derived value; see Annex C
Common cause failure rate (frequency)	2	2	2	2	2	2	2	2	2	1	2	2	1	2	2	1	1	2	Can be identified as one specific failure cause (see C.1.6)
Confidence interval	2	2	2	2	2	2	2	2	2	2	2	2	2	2	2	2	2	2	Derived value; see Annex C

^a For definition of codes/abbreviations A1, QRA, etc., see Table D.1.

Table D.3 (continued)

Data to be recorded ^a	Type of analysis to be applied to the data recorded																		Comments
	A1	A2	A3	A4	B1	B2	B3	B4	B5	B6	B7	B8	B9	C1	C2	C3	C4	C5	
	QRA	RBI	SIL	ESIA	LCC	PA	AA	RCM	SPA	FME	SDA	STR	RCA	MRP	6Σ	FTA	MPA	PNA	
Damage mechanism	2	1	2	2	2	2	2	2	2	2	2	2	1	2	2	2	2	2	Partly covered in failure mechanism and failure cause
Recommended action to eliminate failure cause	2	2	2	2	2	2	2	2	2	2	2	1	1	2	2	2	2	2	—
Spare part	2	2	2	2	2	2	2	2	1	2	2	2	2	2	2	2	2	2	—
Probability of failure on demand	2	2	2	2	2	2	2	2	2	2	2	2	2	2	2	1	1	2	Derived value using selected set of failure modes covered in this International Standard; see also Table B.15 and Annex F

^a For definition of codes/abbreviations A1, QRA, etc., see Table D.1.

Table D.4 — Maintenance data to be recorded

Data to be recorded ^a	Type of analysis to be applied to the data recorded																		Comments
	A1	A2	A3	A4	B1	B2	B3	B4	B5	B6	B7	B8	B9	C1	C2	C3	C4	C5	
	QRA	RBI	SIL	ESIA	LCC	PA	AA	RCM	SPA	FME	SDA	STR	RCA	MRP	6Σ	FTA	MPA	PNA	
Maintenance category	2	2	2	2	1	2	2	1	1	1	1	2	2	1	2	2	2	2	—
Maintenance activity	2	2	1	2	1	2	2	1	1	1	1	1	2	1	2	2	2	2	—
Down time	2	2	1	1	1	1	1	1	1	2	1	2	2	1	1	1	1	1	—
Active maintenance time	2	2	2	1	1	1	1	1	1	2	1	2	2	1	2	1	1	1	—
Maintenance man-hours, per discipline	2	2	2	1	1	1	1	1	1	2	2	2	2	1	2	2	2	2	—
Maintenance man-hours, total	2	2	2	1	1	1	1	1	1	2	2	2	2	1	2	2	2	2	—
Date of maintenance action	2	2	1	1	2	2	2	2	2	2	2	2	2	1	2	2	2	2	—
Maintenance impact on plant operations	2	2	2	2	2	2	2	2	2	2	2	2	2	2	2	2	2	2	—
Lead time	2	2	2	2	2	2	2	2	1	2	2	2	2	2	2	2	2	2	—
Spare part	2	2	2	2	2	2	2	2	1	2	1	2	2	2	2	2	2	1	—
Repair workshop cycle time	2	2	2	2	2	2	2	2	1	2	2	2	2	2	2	2	2	2	See Annex E, Table E.3, KPI no. 27
Maintenance tools	2	2	2	2	2	2	2	2	2	2	1	2	2	2	2	2	2	1	—
Repair rate	2	2	2	2	2	2	2	2	2	2	2	2	2	2	2	1	1	2	Derived value; see Annex C
Test efficiency	2	2	2	2	2	2	2	2	2	2	2	2	2	2	2	1	1	1	Derived value defined as the fraction of failures discovered on test
Confidence interval	2	2	2	2	2	2	2	2	2	2	2	2	2	2	2	2	2	2	Derived value; see Annex C
Priority of the repair	2	2	2	2	2	2	2	2	2	2	2	2	2	2	2	2	2	1	—
Test interval	2	2	2	2	2	2	2	2	2	2	2	2	2	2	2	1	1	1	—

^a For definition of codes/abbreviations A1, QRA, etc., see Table D.1.

D.5 Reliability data sources

Reliability data sources can be of various types, as classified in Table D.5.

Table D.5 — Classification of reliability data sources

Source of data	Description
1. Generic data	<p>Reliability data covering families of similar equipment.</p> <p>Such generic data can be:</p> <p>Computerized database of data, typically grouped in data tables with several equipment attributes. The related historic data collection can be done according to published standards</p> <p>Published data handbooks (e.g. the OREDA handbook), sometime simplified versions of computerised databases. The formats can depend on the publisher. Such data handbooks would normally be historic data, i.e., operating field experience.</p> <p>Published data handbook based on expert judgement, but not on historic operating data or underlying database.</p> <p>The data can apply for one specific industry, or it can be collected from several industries.</p> <p>NOTE Some industrial initiatives can provide other data, (e.g., failures detected during test) that might be useful for establishing reliability data input.</p>
2. Operator/ company specific data	<p>Reliability data or reliability indicators based on operating field experience of a single company. Such data can be established by one operator/oil company from:</p> <ul style="list-style-type: none"> • One or several of its installations, • Its own interpretation of different data sources, • Key Performance Indicators (KPI) <p>NOTE 1 Such operator/company specific data can be part of an industrial cooperation generic reliability database, or purely own company data.</p> <p>NOTE 2 The data can also be part of a company database that complies with this international standard.</p> <p>NOTE 3 Annex E exemplifies KPIs.</p> <p>NOTE 4 The events recorded in a CMMIS system are not reliability data, but could be used to establish some reliability indicators (e.g. KPI).</p>
3. Manufacturer data	<p>Reliability data produced by a particular manufacturer data for a particular product.</p> <p>Such data can be based on:</p> <ul style="list-style-type: none"> • Operating field experience from <ul style="list-style-type: none"> o The manufacturer himself. The data can be aligned or not with an international standard. o The users (e.g., specific or generic data mentioned above) • Component FMECA/ studies, • Laboratory testing, e.g., accelerated lifetime testing, and reliability testing. This can apply for new technology equipment for which experience data not yet exist. Such pre-operational data should normally be entitled 'pre-operational/test reliability data', as opposed to actual field operating experience. See also IEC 61164:2004 for statistical tests and estimation methods for reliability growth.
4 Expert judgement	<p>Expert judgement would involve</p> <ul style="list-style-type: none"> • General advice from safety system equipment expert • Use of statistical expert analysis methods (e.g., Delphi, etc.) to utilise a variety of qualified sources as input to the reliability analysis <p>(see references: van Noortwijk et al., 1992 and Cooke, 1992)</p>
5. Human error data	<p>Various sources of human error data exist. ISO/TR 12489:2013, Annex H.2, gives some advice about human error probabilities.</p>

It is a weakness in the industry that too little attention is given to the quality of the input data. Therefore, undertaking the qualification of reliability data found in data sources is vital for the credibility of the results in risk decision making. ISO 20815:2008, Annex E, gives further advice on this qualification topic.

1. Generic data:

Generic data are often (but not necessarily), see Table D.5 based on operational experience from a number of installations and a number of comparable equipment types, such as e.g., flame detectors from different vendors. In such case the generic data reflect some kind of average expected field performance for the equipment type under consideration.

At early project stages generic data is often selected due to lack of detailed information as all equipment features decisions have not yet been made. However at later project stages one should preferably apply valid application or equipment specific data – if well documented and considered relevant.

2. Operator/company specific data

Authorities require that the companies keep control of their safety barriers throughout the entire lifecycle of an installation. Consequently, it is often required for the operators to collect installation specific failure data during maintenance and operation. During modification analyses such data are of particular relevance for the purpose of documenting the performance history of given equipment. However, since the statistical confidence in data from only one installation can often be poor (or all potential failure events cannot have occurred so far at the installation), reliability analyses are seldom based on such data alone. However, for some equipment where the number of installed units is high, e.g., fire and gas detectors, it can be relevant to apply installation specific data only.

3. Manufacturer data

It is often stated by the analyst that supplied manufacturer data are significantly “better” than comparable generic data (i.e., lower failure rates). This can have several reasons, such as varying equipment quality, failure modes included and the definition of equipment boundaries. Another important aspect, however, is that failures due to environmental stress, due to mal-operation, installation failures, maintenance errors, etc. have frequently been excluded from the manufacturer data. This is understandable since manufacturers are in the business of selling and does not want to include failures that can be attributed to factors external to the equipment itself. Also, if the vendor charges for failure analysis this is a disincentive to return the failed components. Another aspect is the fact that feedback from the operators using the equipment can be poor (especially beyond the warranty period) and in such case it is difficult for the manufacturer to establish a good failure rate estimate. Consequently, using data from manufacturers can involve too low failure rates and as such needs to be carefully considered. It is therefore advisable to deploy the principles of this International Standard to strengthen the quality of the data and the communication on these matters.

When using manufacturer data the reliability engineer should remember to add failures due to connection blockage which are often included in field experience data but excluded from manufacturer data.

4. Expert judgement data

The use of experts to estimate reliability data requires qualification of that the expert is an equipment expert, and understands the methods being used in reliability data estimation. This International Standard provides good guidance on such matters, even though not all type of equipment is covered. If experts are used it would also be beneficial to undertake independent reviews and also be conscious in how reliability data are being communicated, e.g., number of observable events for a given fleet of equipment units at an installation for a certain period of time would be more practical than estimating failure rates in 10^{-6} per hrs. Separate methods exist for expert data analysis.

5. Human error data

Observations or other information can be used to quantify the failed human interactions:

- generic data (look-up tables);

- collected data (calculated human error probability) specific to the task;
- estimation methods (expert judgement);
- combination of the above.

Annex E (informative)

Key performance indicators (KPIs) and benchmarking

E.1 General

Reliability and maintenance (RM) data can be used for developing and managing key performance indicators (KPIs) and for compiling Benchmark information. The objective of both Benchmarking and KPIs is to assist in the management of business improvement. This Annex gives some examples of KPIs, which can be extended, as deemed necessary, using the taxonomy classification in Figure 3. (Some of the principles described below are based on NPRA, 2002 and Hernu, 2000).

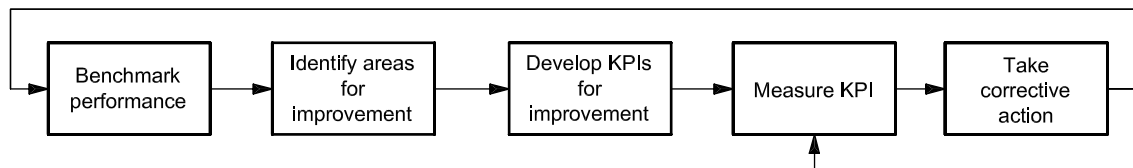

Figure E.1 — Process for using KPIs and benchmarking for improving business performance

The process depicted in Figure E.1 is a simplified version of how KPIs can be developed.

KPIs should be aligned to the objectives of the organization using them and, thus, the organization is free to define the KPIs in whatever way best contributes to the improved performance of the organization.

Improvement is an essential ingredient of successful companies. Performance indicators and benchmarking can be highly effective in identifying and improving areas of greatest opportunity.

For each of the activities in the process represented in Figure E.1 a brief description is given in the list items a) to e).

a) Benchmark performance:

Use is made of benchmarking data to determine the performance of the organization in key areas. These benchmarks can then be used for comparison, usually external, against organizations in the same or similar industry, or against organizations in different industries that have similar business processes.

However, measuring performance gaps with the better performers in a peer group is only half the value of benchmarking. Analyses that can be made of differences of plant profile, practices and organization (the causal factors) explaining these performance gaps are also invaluable knowledge for benchmarking study participants.

b) Identify areas for improvement:

Based on the external benchmarks and the objectives of the organization, areas for improvement can be identified. The areas for improvement are not necessarily the areas where the performance is poor against the other benchmarks, as the areas of poor performance might not correspond with the areas that are critical for the business objectives.

In addition, benchmarking is a tool to prove the business case for the necessary up-front management commitment and investment of the resources to be mobilized for the successful implementation of a performance-improvement project. Benchmarking can be conducted inside the company, within the industry or across industries (as long as the same business process is being dealt with). In the

former case, a “best of the best” networking-type process is effective in performance upgrades. Use of benchmarking within an industry allows a company to recalibrate its performance targets and to re-examine the justification of historic policies and practices in the light of those of the better industry performers.

c) Develop KPIs for improvement

In the areas where improvement is desired, KPIs should be developed. Each KPI should have a targeted performance level. The KPI and target should, where possible, be specific, measurable, achievable (but require stretch), realistic and time-based (i.e. can track performance improvement over time). The frequency at which the KPI is measured is determined by a realistic expectation of the amount of time required for any corrective action to have an impact on the performance level. Thus, one does not want to measure and analyse the parameters when there is no change from one measurement to the next, but it is necessary to balance this against not measuring often enough, resulting in the situation that parameters can be out of control for long periods. In addition, it is necessary to consider the time, cost and resources needed to develop, maintain and manage the KPIs, as this also determines how many robust KPIs can be used.

d) Measure KPI

The KPI should be measured and reported, where possible, within existing systems. In addition to measuring the KPI, it is necessary to compare the result against the target and to identify any causes for deviations.

e) Take corrective action

The causes for deviations should be addressed and corrective actions performed, and the process should be repeated many times.

This Annex focuses on the use of KPIs and Benchmarking by Operating Organisations but the same process can also be adopted, as is encouraged to be, by the wider supply chain. For example, Equipment Manufacturers could adopt similar measures to report design and actual performance of their products, improving equipment selection and helping to ensure sustained production (or system) availability and HSE performance of the production facilities. Consistent definitions, boundary definitions, and data quality as defined in this standard are essential to improve data collection in this area.”

E.2 Alignment to business objectives

E.2.1 General

KPIs are aligned to the organization’s objectives for the facility (or operations) and improvements are identified and implemented in order to achieve the organization’s planned objectives. The alignment of KPIs to the business objectives can be represented as shown in Figure E.2.

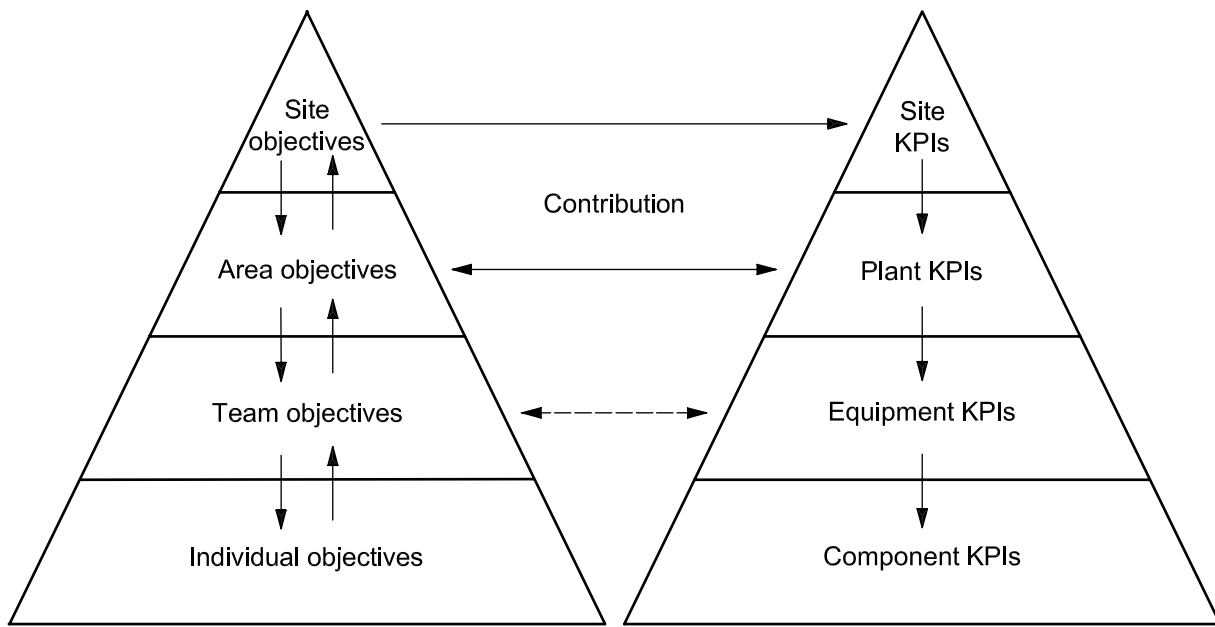

Figure E.2 — Alignment of KPIs to the business objectives

E.2.2 Differences between benchmarks and KPIs

The differences between benchmarks and KPIs are rather subtle. The major difference between a KPI and a benchmark is related to the usage. In effect, a KPI is used for managing an improvement on an ongoing basis and for determining the progress towards a predetermined target. A benchmark is used as a one-off, or low-frequency, event to determine the present performance levels against other organizations involved in the same process.

The table below provides an overview of the major differences.

Table E.1 — KPIs versus benchmarking

Characteristic	KPIs	Benchmark
Purpose	Track progress and effectiveness of management	Identify gaps in present performance level
Frequency	Reasonable expectation of change occurring	One-off/infrequent
Source of data	Internal systems	External sources
Level of control	Immediate to short-term	Longer-term
Number of influencing parameters	One or few	Many
Accuracy	Interested in trend	Interested in absolute value
Targets	Set, based on objectives	No target

E.3 Using benchmarking

E.3.1 Benchmarking principles

Benchmarking helps determine the reference point and standard from which world-class performance can be measured. The process of benchmarking can be broken down into three steps.

- a) Evaluate and measure your own operation or specific process to identify weaknesses and strengths using the data collected in accordance with Clauses 7, 8, and 9. Choose a set of KPIs (see Table E.3).

Align them to the organisation's objectives for the facility (or operations), identify areas for improvement, collect and analyse the data and implement improvements in order to achieve the organization's planned objectives.

- b) Initiate a benchmarking study and document processes by referring to peer groups (see E.3.7) that are more productive or efficient than yours.
- c) Identify best practices and implement them.

E.3.2 General

Benchmarking is most useful where there is an existing statistically significant sample population. It is necessary that those individuals involved in the exchange of information understand the inherent limitations imposed by the data they collect and the database where it is stored. For example, depending on the type, load, speed, mounting method, lubricant formulations, contamination levels, etc., a given bearing can last anywhere from 18 months to 40 years; therefore, knowing the average MTTF of all bearings in a given plant would be of only limited usefulness to a reliability engineer. For company A, who is operating with a MTTF of 18 years, to approach the reliability of company B who is operating with a MTTF of 40 years, it is necessary that there be an underlying knowledge of all of the differences in the design and operating conditions. The development of best practices cannot occur where there is not already a sound knowledge of engineering principles.

A frequent misuse of benchmarking is to consider it merely as a scorecard, that is to say, for looking backward to measure past success or failure, rather than as a map to guide forward progress to achieve goals and continue improvement.

E.3.3 Taxonomy level

Benchmarking can occur at the plant, process-unit, equipment-class, subunit or maintainable-item level. Key performance indicators for each hierarchical level (see Figure 3) provide different information. If a KPI set at one taxonomic level highlights a weakness, then the next lower taxonomy level of indicators should give further definition and clarification to the causes of the weakness. Benchmarking initiatives that rank plant or process-unit performance often look at relative levels of reliability, staffing, utilization and operating cost. KPIs for hierarchies at the level of equipment class and below include parameters that principally focus on the incidence of failure and repair. Where a "best practice" for continuous improvement on a process unit can, for example, involve the implementation of reliability-centred maintenance, the best practice at a lower hierarchy can be the implementation of more rigorous design specifications, balance or grouting requirements, etc.

E.3.4 Choice of benchmarks

KPIs that together can measure overall reliability and maintenance effectiveness within this International Standard are the following:

- a) equipment-class, subunit and maintainable-item mean time to failure (MTTF, see definition in Clause 3);
- b) availability (see definition in Clause 3);
- c) cost of production losses caused by unreliability and by maintenance activity;
- d) direct costs (labour, contracts and materials) of maintenance work;
- e) costs of maintenance support staff and of maintenance consumables;
- f) ensure maintenance activities are executed according to plan.

E.3.5 Alignment of benchmark and KPIs across peer groups

It is important that all benchmarking contributors supply a complete set of key performance indicators (KPIs) that are tied to the same frame of reference. To do this, the more successful benchmarking initiatives are the following.

- Identify those elements that most affect the commercial success of the business.
- Employ generic terms for each element: the descriptions of boundaries and the collection of data should be chosen in accordance with this International Standard.
- Provide sufficiently detailed definitions to promote and enable a consistent response by each participant and ensure that all performance data apply to the same time frame.

E.3.6 Benefits of benchmarking

Benchmarking may be used to provide continuous improvement to key work-process elements of plant maintenance and reliability including

- a) strategy/leadership,
- b) maintenance work management,
- c) predictive and preventive maintenance,
- d) computerized maintenance management information systems (CMMIS),
- e) training,
- f) materials management,
- g) contractor management,
- h) reliability improvement,
- i) competitive technology/benchmarking.

Confidential industry benchmarking of the reliability and maintenance function has become an essential tool for performance-improvement programmes. It has the primary objective of providing companies with useable comparative data that, at a level of detail that is actionable, helps them focus on credible opportunity targets to improve their performance.

To gain credibility and acceptance, it is necessary that these opportunity targets be seen as realistic, that is, they are understood by, and credible to, those responsible for achieving them.

Users of this International Standard are cautioned against focusing on only one or two of the KPIs and neglecting others.

E.3.7 Selection of peer groups

E.3.7.1 General

The selection of the peer group against which a participating plant compares its performance data is important. If this peer-group selection is well made, personnel in the plant will have confidence that it has the same performance opportunity as the better-performing plants in the group. Furthermore, use of a suitable method of analysis of physical causal factors, of plant characteristics and of maintenance practices within the group provides explanations of variations in performance that have greater validity.

When a plant's performance is seen to be poor compared with its peer group, the gap can be due both to differences in the plant's physical features (even within the same peer group) and also to differences in the practices and organization of the site. The characteristics of both categories of causal factor should

be benchmarked using a suitable method of benchmarking, so that the relative weight of each can be judged and realistic targets set.

E.3.7.2 Selection of peer groups

A peer group's distinguishing factor is a feature of a plant that affects one or several aspects of performance and is common and intrinsic to the group of plants and also that a plant cannot change in the short/medium term.

The two peer-group distinguishing factors that have been found most significant in studies on reliability and maintenance are

- process family: for reasons of equipment types, process severity (corrosivity, toxicity, etc.) and maintenance complexity;
- geographic region: for reasons of prevailing labour hourly costs, employment and contracting practices, safety and environment-protection norms, climate, management culture and industrialization level of the region.

E.4 Examples of benchmarks and KPIs using RM data

There are a variety of benchmarks and KPIs available. Measurement of costs and failure rates provides indications of trends in the effectiveness of maintenance and reliability programmes. KPIs can also be used to gauge an organization's adherence to programmes and procedures by recording compliance with preventive or predictive schedules.

No single KPI provides the complete picture and it is, therefore, necessary to define a basket of KPIs that together indicate progress and trends in the reliable operation of plant and equipment. Trends can be shown over a period of time and can require some special attention to allow for periodical as well as accumulative reporting, for example, "last-two-years average" in the latter case.

Table E.3 gives examples of KPIs that can be developed making use of RM or other reliability-related data. For further information on the sources of reliability data, see [D.5](#) and [Table D.5](#). Other/more KPIs can be useful depending on industry and application. In Table E.3, reference is made to the taxonomic levels in Table 2. These are suggestions and in some cases KPIs can be rolled up to Level 3.

Table E.2 — Taxonomic levels

Main category	Taxonomic level	Taxonomic hierarchy	Use/location
Use/location	1	Industry	Type of main industry
	2	Business category	Type of business or processing stream
	3	Installation category	Type of facility
	4	Plant/unit category	Type of plant/unit
	5	Section/system	Main section/system of the plant
Equipment sub-division	6	Equipment (class/unit)	Class of similar equipment units. Each equipment class contains similar pieces of equipment (e.g. compressors).
	7	Subunit	A subsystem necessary for the equipment unit to function.
	8	Component/maintainable item	The group of parts of the equipment unit that are commonly maintained (repaired/restored) as a whole
	9	Part ^a	A single piece of equipment
^a While this level may be useful in some cases, it is considered optional in this International Standard.			

Table E.3 — Examples of KPIs ^a

KPI	Relevant taxonomic levels ^b	Units	Explanation and calculation	Purpose and value	Involved personnel
1) METBF Mean elapsed time between failures	6 to 8	Time (hours, days, weeks, months, years) For different classes or types of equipment Trends are shown over a period of time	Indicates the average time between failure for components, equipment or units. Definition of failure is given in Clause 3 (general) and Annex F (safety equipment). Use of METBF implies that down time/repair is included. Guidelines for calculating METBF (and MTTF) are given in Annex C.	Indication of increasing or decreasing reliability of components, equipment or unit/plant	Equipment subject-matter experts (SMEs) Reliability engineers (REs) Middle management (MM) Inspection
2) MTTF Mean time to failure	6 to 8	As above	Is similar to METBF, but does not take into account the down time/repair time. METBF is the sum of MTTRes and MTTF. MTTF equals the reciprocal of the failure rate.	As above Note that MTTF, in principle, concerns only the first time to failure of a new item before any maintenance task has been performed	As above
3) MTBR Mean time between repairs	6 to 8	Time (hours, days, weeks, months, years) For different classes or types of equipment Trends are shown over a period of time	Indicates the average time between repairs for components, equipment or units. Although a failure typically results in a repair, this is not always the case. Repairs (e.g. major overhauls) can be undertaken on a time basis independent of failure. Calculation based on total time between repairs divided by number of repairs over a specified time period or to date. For subsea equipment, one may rename the KPI to “Mean time between interventions” (MTBI).	Indication of increasing or decreasing reliability of components or equipment within a plant/unit	SMEs REs MM Maintenance Inspection

^a Other/more KPIs can be useful depending on industry and application.

^b See Table E.2.

^c CM is sometimes used as an abbreviation for corrective maintenance, but in this document CM refers to Condition monitoring

Table E.3 (continued)

KPI	Relevant taxonomic levels ^b	Units	Explanation and calculation	Purpose and value	Involved personnel
4) Mean active repair time (MART)	6 to 8	Time usually in hours or days. For different classes or types of equipment Trends are shown over a period of time	The time taken to perform the repair of a component, equipment, system or unit. It is necessary that MART follows the timeline principles given in Figure 4, and also ISO/TR 12489:2013, Figure 5 to 7. One may introduce MDT (Mean down time) if it is also of interest to monitor the preparation and delay times, but such a KPI is not explicitly included in this table.	Indication of the productivity and work content of repair activities	SMEs REs Maintenance
5) Mean overall re-pairing time (MRT)	6 to 8	Time usually in hours or days. For different classes or types of equipment Trends are shown over a period of time	The time taken to prepare and perform the repair of a component, equipment, system or unit. It is necessary that MRT follows the timeline principles given in Figure 4, and also ISO/TR 12489:2013, Figure 5 to 7. One may introduce MDT (Mean down time) if it is also of interest to monitor the preparation and delay times, but such a KPI is not explicitly included in this table.	Indication of the productivity and work content of repair activities	SMEs REs Maintenance
6) Worst actors List of frequently failed equipment	6 to 9	List of equipment List of frequent failure modes Frequency of failure	Clear definition of which failure types are covered is necessary (see Annex C). List of most frequently failed equipment can also be generated by frequency of repairs. List can also be used for sub-supplier reliability management follow-up. Restructure as to plant impact.	Provides focus for reliability management and root cause failure analysis (RCA) Product/quality development	As above
<p>^a Other/more KPIs can be useful depending on industry and application.</p> <p>^b See Table E.2.</p> <p>^c CM is sometimes used as an abbreviation for corrective maintenance, but in this document CM refers to Condition monitoring</p>					

Table E.3 (continued)

KPI	Relevant taxonomic levels ^b	Units	Explanation and calculation	Purpose and value	Involved personnel
7) A ₀ Operational availability	6	% time available for operation of the equipment when all maintenance (corrective and preventive) is included in the down time	Normally on equipment-unit level.	Shows trend in equipment availability when both corrective and preventive maintenance is covered Input for production planning (see C.2.3)	SME REs MM Operations Maintenance Inspection
8) A _T Technical availability	6	% time available for operation of the equipment when corrective maintenance only is included in the down time	Normally on equipment-unit level.	The key technical-availability indicator Shows trend in equipment availability focusing on intrinsic reliability (see C.2.3)	SMEs REs MM Operations Maintenance Inspection
9) Safety critical elements with assurance tasks in CMMS	4 to 6	% of safety critical equipment with assurance tasks in the CMMS.	Top Quartile: 100%. Tracked Annually.	Ensure all Safety Critical Elements requiring assurance tasks have them assigned in the CMMS.	Asset Manager Operations Maintenance
10) Safety critical element planned maintenance compliance (not beyond latest allowable finish date)	4 to 6	% of Planned Maintenance WOs for safety critical equipment outstanding after the last scheduled finish date.	Top Quartile >98%. Tracked Monthly.	Measure safety critical element planned maintenance work completed before last approved finished date	Asset manager Operations Maintenance
11) Safety Critical Element Corrective Maintenance compliance (not beyond Latest Allowable Finish Date)	4 to 6	% of Corrective Maintenance WOs for safety critical equipment outstanding after the last scheduled finish date..	Top Quartile >98%. Tracked monthly	Measure safety critical element corrective maintenance work completed before last approved finished date	Asset Manager Operations Maintenance
12) Preventive maintenance (PM) man-hours ratio	4 to 6	% of total maintenance man-hours spent on PM (not including modifications)	Total PM work order (WO) man-hours divided by total WO man-hours, by equipment classification or types.	Indication of amount of proactive preventive maintenance work	SMEs REs Operations Maintenance

^a Other/more KPIs can be useful depending on industry and application.

^b See Table E.2.

^c CM is sometimes used as an abbreviation for corrective maintenance, but in this document CM refers to Condition monitoring

Table E.3 (continued)

KPI	Relevant taxonomic levels ^b	Units	Explanation and calculation	Purpose and value	Involved personnel
13) Corrective maintenance ^c man-hours ratio	4 to 6	% of total maintenance man-hours spent on corrective maintenance	Total corrective maintenance WO man-hours divided by total WO man-hours, by equipment classification or types.	Indication of amount of corrective maintenance work	SMEs REs Operations Maintenance
14) Overdue Assurance or Safety Critical work orders on Safety Critical Elements without Technical Authority (TA) approval	4 to 6	Number of assurance tasks for safety critical equipment that is beyond the Last Allowable Finish Date without technical authorisation.	Top Quartile: 0 per Plant/Unit Tracked monthly.	Check Safety Critical Elements work orders are not being rescheduled without appropriate Technical approval.	Asset Manager Operations Maintenance
15) PMs overdue	4 to 6	Number or % of PM WOs overdue by category	Count of outstanding PM WOs by equipment classification or as a % of total PM WOs. One may also select only safety-critical equipment or production-critical equipment to differentiate into groups.	Indication of outstanding PM backlog	Operations Maintenance
16) Predictive maintenance (PdM) complete Completion of predictive maintenance (e.g. inspections, testing, periodic condition monitoring)	4 to 6	Number or % PdM data collection activities completed	Define which predictive-maintenance activities to cover, individually or all. For example, number of data points, routes or equipment that have PdM NDT data collection carried out divided by total data points, routes or equipment, over a specified period of time. (Vibration analysis data, thickness readings, infrared scans, motor performance analysis).	Condition monitoring management	SMEs REs Operations Maintenance Inspection
17) Predictive maintenance (PdM) overdue	4 to 6	Number or % overdue predictive maintenance (PdM) activities	Define which predictive maintenance activities to cover, individually or all. Count or % of PdM NDT data points, routes or equipment that are outstanding over a specified time period of time.	Indicates backlog of PdM type of activities, e.g. NDT	SMEs REs Operations Maintenance Inspection
18) Corrective maintenance workload	4 to 6	Number of hours work recorded for corrective maintenance.	Top Quartile < 6 man weeks. Tracked monthly	Ensure number of hours of corrective maintenance is under control.	Asset Manager Operations Maintenance

^a Other/more KPIs can be useful depending on industry and application.

^b See Table E.2.

^c CM is sometimes used as an abbreviation for corrective maintenance, but in this document CM refers to Condition monitoring

Table E.3 (continued)

KPI	Relevant taxonomic levels ^b	Units	Explanation and calculation	Purpose and value	Involved personnel
19) Schedule compliance	4 to 6	% of scheduled total maintenance man-hours completed over a rolling three month period.	Top Quartile >98%. Tracked monthly.	Increase compliance with weekly schedule.	Asset Manager Operations Maintenance
20) Un-scheduled/fill-in work	4 to 6	% of maintenance man-hours consisting of unscheduled/fill in work over a rolling three month period.	Top Quartile <2%. Tracked monthly.	Ensure work is being scheduled and the resulting plan adhered to.	Asset Manager Operations Maintenance
21) Turn-around duration	4	Time, usually in days	It is necessary to include run-down and start-up in connection with turnarounds. Prolonged turnarounds due to modifications may be separated out in order not to disturb comparison with year-to-year requirements for major maintenance.	Maintenance planning Modification opportunities Outage planning Production planning	Operations Maintenance
22) Time between turnarounds	4 to 5	Measured on annual basis (number of months, years)	Time between turnarounds.	As above	As above
23) Maintenance estimating accuracy – hours	4 to 6	% difference between planned and actual man-hours for planned and corrective WOs	Top Quartile +/- 5%. Tracked monthly.	Ensure historical data is used in estimating (durations)	Asset Manager Operations Maintenance
24) Maintenance estimating accuracy – cost	4 to 6	% difference between planned and actual costs for planned and corrective WOs.	Top Quartile +/- 5%. Tracked monthly.	Ensure historical data is used in estimating (costs)	Asset Manager Operations Maintenance
25) Repair rework ratio	6	% of repairs where rework is required following repair	Number of WOs that are reworked divided by total number of WOs. Classified by equipment type. May be split into preventive and corrective maintenance.	Indication of work quality and productivity	REs Operations Maintenance

^a Other/more KPIs can be useful depending on industry and application.

^b See Table E.2.

^c CM is sometimes used as an abbreviation for corrective maintenance, but in this document CM refers to Condition monitoring

Table E.3 (continued)

KPI	Relevant taxonomic levels ^b	Units	Explanation and calculation	Purpose and value	Involved personnel
26) CMMS Confirmed to Technical Completion time	4 to 6	Time between work completion and technical close out of the work order.	Top Quartile 24 hours. Tracked monthly.	Ensure history is written within a reasonable time from the end of the activity (typically with 72 hours).	Maintenance
27) Average repair workshop cycle time	6 to 8	Time, usually in hours or days	The time taken from when failed item is received at repair shop until it is ready for use again	Repair management	Maintenance
28) Generic material ordering	4 to 6	% of material items issued that are identified in the CMMS.	Top Quartile <10%. Tracked monthly.	Ensure the Material Catalogue is complete.	Asset Manager Operations Maintenance
29) Materials achieving original Required on Site (RoS) date	4 to 6	% of materials delivered to site in compliance with the original required on site date.	Top Quartile >95%. Tracked monthly.	Reduce delays to corrective and preventive work caused by unavailability of materials.	Asset Manager Operations Maintenance
30) Inventory service level	4 to 6	% of materials required for maintenance satisfied from stock.	Top Quartile +/- 5%. Tracked monthly.	Ensure commonly used materials for maintenance activities are held in stock to reduce time waiting for materials.	Asset Manager Operations Maintenance
31) Total maintenance cost	4 to 6	Per plant, section or equipment for a given period (e.g. annually)	Total cost for both corrective and preventive maintenance including spare parts. Does not include costs related to down time with respect to lost production.	Trend analysis over a period of time	Plant management Operations Maintenance
<p>^a Other/more KPIs can be useful depending on industry and application.</p> <p>^b See Table E.2.</p> <p>^c CM is sometimes used as an abbreviation for corrective maintenance, but in this document CM refers to Condition monitoring</p>					

Table E.3 (continued)

KPI	Relevant taxonomic levels ^b	Units	Explanation and calculation	Purpose and value	Involved personnel
32) Maintenance productivity	4	% of maintenance man-hours consumed by non-productive activities, e.g. awaiting materials, etc.	Top Quartile >50%. Tracked monthly	Non-value added time is recorded and there is a focus on reducing or eliminating non-value added time.	Asset Manager Operations Maintenance
33) Cost of repairs per work order	4 to 6	Cost by different equipment types for various geographical locations, units or plants.	The cost of repair to equipment as represented by the costs collected against equipment work orders. Typically, it includes labour (company and/or contract), materials and equipment hire. Overhead can also be included.	Trend in repair cost over a period of time Identification of worst actors by repair cost and/or equipment type	As above
34) Failure fraction (see F.2.4, and also ISO/TR 12489:2013, 3.2.4).	6	Ratio	Equipment subject to such potential safety critical failures can be identified within a plant and monitored, and the ratio between the number of safety critical failures detected by periodic tests and the corresponding number of tests performed. Tracked annually.	Average unavailability (PFDavg) due to dangerous undetected failures is established by using test reports. This common industry practice for several countries.	Regulatory Authorities Asset manager Operations Maintenance

^a Other/more KPIs can be useful depending on industry and application.

^b See Table E.2.

^c CM is sometimes used as an abbreviation for corrective maintenance, but in this document CM refers to Condition monitoring

Annex F **(informative)**

Classification and definition of safety critical failures

F.1 General

The purpose of this Annex is to make the user of this International Standard aware of some specific definitions and classifications applied for safety critical equipment. IEC has developed the functional safety standards IEC 61508:2010 (all parts) and IEC 61511:2016 (all parts), which have been implemented by many industries including the natural gas, petroleum and petrochemical industries. The general principles described in IEC 61508:2010 (all parts) and IEC 61511:2016 (all parts) have been further developed by national initiatives into guidelines and analysing methods for use in the petroleum industry, for example in (The Norwegian Oil and Gas Association, 2016).

ISO/TR 12489:2013 provides guidance to reliability modelling and calculation of safety systems and is an essential document when equipment reliability data covered by this standard is used. An overview is given in F.2.

As part of this overall purpose, a recommended list of failure definitions for some safety systems and components is given in Table F.1.

F.2 Reliability modelling and calculation of safety systems

ISO/TR 12489:2013 provides guidelines to reliability engineers who deal with probabilistic approaches, which, in association with qualitative considerations, are increasingly used to design reliable safety systems. This is encouraged by regulations (e.g. SEVESO III directive, 2012) or widely recognized standards (e.g. the SIL approach recommended for safety instrumented systems by the IEC 61508:2010 mother standard and the sectorial derived standard like IEC 61511:2016 (all parts) which is focused on process systems). This implies to meet various probability related requirements, but these probabilistic matters are currently rather briefly documented in standards, and not satisfactorily addressed in reliability textbooks. Therefore, ISO/TR 12489:2013 aims at closing this gap by establishing a sound specific probabilistic background, helping the reliability engineers to properly deal with the probabilistic modelling and calculations of any type of safety systems (e.g. ESD, High Integrity Pressure Protection System, etc.). After gathering the relevant definitions and raising the typical difficulties, the technical report explains in detail how to solve them. It analyses in detail how simplified formulae can be established for simple safety systems and how the common standardized models - reliability block diagrams (IEC 61078:2016), fault trees (IEC 61025:2006), Markovian approach (IEC 61165:2006) and Petri nets (IEC 62551:2012) - may be used to deal with more complex situations. Moreover, ISO/TR 12489:2013 develops in detail the approaches mentioned in the IEC 61508:2010, part 6, Annex B, for SIL related calculations. It also provides guidelines about the multiple safety systems mentioned in IEC 61511:2016 (all parts).

Annex A in ISO/TR 12489:2013 provides a list of 31 systems with safety function, and also lists the associated equipment classes in this International Standard, which are of relevance for collection or estimation of reliability data when analysing such systems.

Annex D.5 provides a classification of reliability data sources for use when analysing such systems, but the classification is also useful for reliability data collection and exchange in general.

F.3 Classification of failures of safety instrumented systems

F.3.1 General definitions

Safety Instrumented Systems (SIS) can have great influence on a plant's safety and integrity, and failure of these systems is, therefore, dealt with in a more dedicated way than for other equipment. As these systems are frequently "dormant" in normal use and expected to function when called upon, it is of the utmost importance to reveal any hidden failure before the function is called upon.

Further, it is also of prime interest to know the consequences of a failure of these systems with regard to impact on safety.

Some general commonly used terms in this area are listed below with reference to where the definitions can be found:

- Dangerous failure (see ISO/TR 12489:2013, 3.2.3). These failures impede a given safety action.
- Safe failure (see ISO/TR 12489:2013, 3.2.5). These failures favour a given safety action.
- No-effect failures are failures that have no impact on safety.
- Intrinsically fail safe systems; systems based on a design which favour the safe failures and for which the probability of dangerous failures is negligible.
- Non-intrinsically fail safe system; systems where the probability of dangerous failures is not negligible.
- Immediately revealed failures (see ISO/TR 12489:2013, 3.2.10).
- Hidden failures (see ISO/TR 12489:2013, 3.2.11). These failures may be detected by e.g. periodic tests.

F.3.2 SIS failure mode classification in reliability data collection and analysis

IEC 61508:2010 (all parts) introduces a failure classification that is adapted to SIS. Here the failures are first divided into the two categories:

- random failures (see also definition in 3.79);
- systematic failures (see also definition in 3.90).

The random failures of components are in IEC 61508:2010 further categorized into these failure mode groups:

- dangerous detected (DD);
- dangerous undetected (DU);
- safe detected (SD);
- safe undetected (SU).

Collected reliability data may not contain historic failure mode events within all these four categories, and this will require caution and assumption when establishing failure rates for such "zero failure history". The physical equipment behaviour with respect to the failure modes that apply for a certain component is also vital to understand, to ensure proper allocation of failure data onto these four categories, whereof some perhaps need to be zero.

When collecting reliability data for SIS, two topics should be emphasised:

- common cause failures (see C.1.6 and ISO/TR 12489:2013, 3.2.14)
- test interval (periodic) for identifying dangerous undetected (DU) failures

When a safety/reliability study is performed as described in IEC 61508:2010 (all parts), it is important that the relevant failure modes are classified as DD, DU, SD or SU. See also Table 5 with respect to an information field to allow such data collection on a specific installation. Table B.15 indicates also the demand related failure modes covered by Annex B for the equipment classes covered therein. This supports the applicability of this International Standard to the specific analyses as described in IEC 61508:2010 (all parts).

Some of the collected common cause failures can be systematic failures, and would thus not be categorized as part of the random failure mode groups DU/DD/SD/SU above. Classification of systematic failures is also reflected in ISO/TR 12489:2013, Figure B.5. See also B.2.3.2 in this International Standard.

When recording and/or analysing failures for SIS, it is recommended to consult IEC 61508:2010 (all parts), IEC 61511:2016 (all parts), ISO/TR 12489:2013, and additional national guidelines as deemed relevant.

F.3.3 Downtime issues related to SIS reliability data collection and analysis

Downtime issues are important in reliability data collection and analysis of SIS. ISO/TR 12489:2013, Figures 5 to 7 provide definitions and guidance on such matters, but some specific remarks are given below.

Clause 3 defines the terms “mean overall repairing time (MRT)”, related to the repairs of failures after they have been detected. Another used term is “mean time to restoration (MTTRes)”, which includes both the fault detection and the repair times.

In any case, $MTTRes = MFDT + MRT$. The “mean fault detection time” (MFDT) of the dangerous detected failures (e.g. detected by diagnostic tests) is generally negligible compared to the MRT, and it is reasonable to assume that MTTRes and MRT have the same numerical values for dangerous detected failures.

F.4 Definition of failures for safety systems

F.4.1 General

Risk management of safety systems does also require equipment reliability management and associated data collection. The use by operators of the standard definitions given in Table F.1 would facilitate comparison and benchmarking to enhance safety levels in the industry. Undetected failures are typically called safety critical failures for safety function and such reporting practices exists involving regulator.

According to ISO/TR 12489:2013, 3.2.4, the dangerous failures that disable a Safety Instrumented Function (SIF) are labelled *safety critical failures* with regards to this SIF. The safety critical failures can be identified within a plant and monitored, and the ratio between the number of safety critical failures detected by periodic tests and the corresponding number of tests performed (commonly called “*failure fraction*”) is being used for that purpose. This indicator is the instantaneous unavailability (see ISO/TR 12489:2013, 3.1.11) at the time of the test, and it is a conservative estimate of the average unavailability (PFD_{avg}) (see ISO/TR 12489:2013, 3.1.14). It is thus important not to mix the “failure fraction” with other reliability terms, such as e.g. the term “safe failure fraction” (see IEC 61508-4:2010, 3.6.15).

In this context it should be noted that the term “critical” has not the same meaning in ISO/TR 12489:2013 and in this International Standard:

- This International Standard: The term “critical” is related to the failure impact of a failure on an equipment function(s) or on the plant (see 3.28). On the equipment level (taxonomy level 6, and

ISO 14224:2016(E)

also underlying level), “critical” is one of the three failure impact classes (critical, degraded and incipient). Thus, this term here is related to the degree of the failure itself.

- The non-critical failures are the degraded + incipient failures as defined by this International Standard.
- ISO/TR 12489:2013: The term “critical” is related to the effect of the failure on the safety function. It characterizes a failure completely disabling a safety instrumented function.
 - In the context of functional safety, the non-critical failures are those which do not disable the related SIF.

Let us consider a SIF implementing two redundant equipment items A and B:

- according to this International Standard, the dangerous failure of item A can be critical, degraded or incipient independently of the state of item B;
- according to ISO/TR 12489:2013, the dangerous failure of item A is critical only if
 - it is critical according to this International Standard and
 - item B already has had a dangerous critical failure according to this International Standard.

Therefore, due to the above issues, the term critical and non-critical failures will thus require caution.

The analyst needs to carefully consider which failure modes of the equipment are relevant with regards to the reliability analysis of the safety function. In this context the relevant items within the equipment boundary necessary for the safety function needs to be covered (i.e. detection, decision and action).

F.4.2 Recommended definitions

The list below provides recommended definitions where also technical and operational criteria for failure modes are given. The applicable failure modes are shown as elsewhere listed in Table B.15.

Note that the Table F.1 contains failures revealed during testing. Note that Table 5 mentions operational and test activation.

Table F.1 — Recommended definitions of failures for some safety systems/components (revealed during testing)

System/ component	Equipment class	Recommended failure definitions	Applicable failure modes ^{a,c,g}
1. Fire detection (smoke, flame, heat)	Fire and gas detectors ^b	Detector Fire and gas logic does not receive signal from detector, when detector is tested.	NOO, LOO, FTF
2. Fire detection (manual call point)	Input devices ^b	Manual call point Fire and gas logic does not receive a signal from the pushbutton when activated.	NOO, LOO, FTF
3. Gas detection	Fire and gas detectors ^b	Detector (catalytic, optical point, H₂S and H₂) Fire and gas logic does not receive signal equivalent to upper alarm limit when testing with prescribed test gas.	NOO, LOO, FTF
		Detector (optical line) Fire and gas logic does not receive signal equivalent to upper alarm limit when testing with prescribed test filter.	NOO, LOO, FTF
		Detector (acoustic) Fire and gas logic does not receive signal when tested.	NOO, LOO, FTF
4. Active fire protection (deluge)	Valves ^b	Deluge valve Deluge valve fails to open when tested.	FTO, DOP
	Nozzles	Nozzle More than 3 % of the nozzles are plugged/choked. Failures are reported per skid/loop.	PLU
5. Active fire protection (fire-fighting pump)	Pumps ^b	Function Fire-fighting pump fails to start upon signal.	FTS
		Capacity Fire-fighting pump delivers less than 90 % of design capacity.	LOO
6. Active fire protection (gaseous agent /Inergen)	Valves ^b	Function Release valve fails to open upon test. Valve does not open on signal or agent pressure/level is below specified minimum.	FTO
7. Active fire protection (water mist)	Valves ^b	Function Release valve fails to open upon test. The system pressure upstream release valve is not within specified value or nozzle does not function properly.	FTO
8. Active fire protection (fire-fighting foam)	Fire-fighting equipment	Function Water/foam does not reach fire area upon test.	FTO, DOP, FTS
9. Active fire protection (Sprinkler valve)	Valves	The valve does not open on test.	FTO

Table F.1 (continued)

System/ component	Equipment class	Recommended failure definitions	Applicable failure modes ^{a,c,g}
10. Active fire protection (Fire water monitor – remotely operating/ oscillating function)	Fire-fighting equipment	The monitor does not operate/ oscillate, and/or does not deliver water/foam to defined target area with expected amount	FTF
11. Active fire protection (Fire water monitor valve (actuated))	Valves	The valve does not open on signal.	FTO
12. Depressurization valves (blow-down)	Valves ^b	Valve Valve fails to open upon signal or within specified time limit.	FTO, DOP
13. PA system (loudspeakers), sirens and signal lights	Emergency communication	Loudspeaker announcement or sirens do not sound, or signal light not activated in prescribed area upon signal.	FTF
14. Blowout preventers (BOP)	Subsea BOP, Surface BOP	Function Valve fails to close upon signal or within a specified time limit.	FTC, DOP
		Leakage Internal leakage higher than specified value at first test.	LCP
15. ESD (sectioning valves defined as safety-critical)	Valves ^b	Function Valve fails to close upon signal or within a specified time limit.	FTC, DOP
		Leakage Internal leakage higher than specified value.	LCP
16. ESD (well isolation)	Subsea wellhead and X-mas tree. Surface wellhead and X-mas tree ^b	Function Valve fails to close upon signal or within a specified time limit.	FTC, DOP
		Leakage Internal leakage higher than specified value at first test.	LCP
17. ESD (downhole safety valve)	DHSV ^b	Function Valve fails to close upon signal or within a specified time limit.	FTC, DOP
		Leakage ^f Internal leakage higher than specified value.	LCP
18. Annulus safety valve (ASV)	Well completion	Function Valve fails to close upon signal or within a specified time limit.	FTC, DOP
		Leakage Internal leakage higher than specified value.	LCP

Table F.1 (continued)

System/ component	Equipment class	Recommended failure definitions	Applicable failure modes ^{a,c,g}
19. Gas lift valves (GLV) ^h	Well completion	Function Valve fails to close upon signal or within a specified time limit.	FTC, DOP
		Leakage Internal leakage higher than specified value.	LCP
20. ESD (riser)	Valves ^b	Function Valve fails to close upon signal or within a specified time limit.	FTC, DOP
		Leakage Internal leakage higher than specified value.	LCP
21. ESD (push button)	Input devices ^b	Function The ESD logic does not receive a signal from the push button when activated.	NOO, LOO, FTF
22. ESD (electric isolation/ISC)	Switchgear ^b	The breaker does not open on demand ensuring disconnection of electrical distribution boards and/or main consumers (drives).	FTO, FTF
23. Process safety (sectioning valves)	Valves ^b	Function Valve fails to close upon signal or within a specified time.	FTC, DOP, LCP
24. Process safety (PSV)	Valves	Function Valve fails to open at the lesser of 120 % of set pressure or at 5 MPa (50 bar) above set pressure.	FTO
25. PSD (Non-return valve, safety critical, leakage)	Valves	The valve has a higher internal leakage rate than the specified acceptance criterion	LCP
26. PSD (HIPPS valve, function)	Valves ^b	Valve does not move to predefined safe position on signal within the specified permitted time	FTO, FTC, DOP
27. PSD (HIPPS valve) ^d	Valves ^b	Valve has a higher internal leakage rate than the specified acceptance criterion	LCP, DOP
28. Input devices (pressure, temperature, level, flow, etc.)	Input devices ^b	Function Sensor does not give signal or gives erroneous signal (exceeding predefined acceptance limits).	NOO, ERO, LOO, HIO
29. Emergency power (emergency generator)	Electric generators ^b	Function Emergency generator fails to start or gives wrong voltage upon start.	FTS, LOO
30. Emergency power (central UPS for SIS)	Uninterruptible power supply ^b	Function Battery capacity too low.	LOC
31. Emergency power (UPS for emergency lighting)	Uninterruptible power supply ^b	Function Battery capacity too low. For emergency lights: When one or more emergency lights within one area or circuit fails to provide lighting for minimum 30 min.	LOC
32. Fire damper ^e	Fire-fighting equipment ^b	Function Damper fails to close upon signal	FTO, DOP, FTS, FTC

Table F.1 (continued)

System/ component	Equipment class	Recommended failure definitions	Applicable failure modes ^{a,c,g}
33. Natural ventilation and HVAC: HVAC transmitters (air flow or pressure differential), safety related	HVAC ^b	Function The safety trip/alarm logic does not receive a signal from the sensor when the measured process parameter is outside of the set point limit, or sensor output signal deviates from true air flow or pressure conditions (margins unless specified otherwise, +/- 5 %).	FTF
34. Natural ventilation and HVAC: HVAC switches (air flow or pressure differential) safety related	HVAC ^b	Function The safety trip/alarm logic does not receive a signal from the sensor when the measured process parameter is outside of the set point limit, or sensor output signal deviates from true air flow or pressure conditions (margins unless specified otherwise, +/- 5 %).	FTF
35. Ballast system (valves)	Valves ^b	Function Valve fails to operate on signal.	FTO, FTC, DOP
36. Ballast system (pumps)	Pumps ^b	Function Pump fails to start/stop on signal.	FTS
37. Watertight doors, closure	Evacuation, escape and rescue	The door does not close and latch on signal or the door gasket is not intact.	FTF
38. Watertight damper (e.g. butterfly valve)	Fire-fighting equipment ^b	The damper does not close on signal.	FTC, DOP
39. Escape, evacuation and rescue (EER): Lifeboat engine, start	Lifeboats	Lifeboat engines does not start on test	FTS
40. Escape, evacuation and rescue (EER): Lifeboat free fall release function	Lifeboats	Release function for lifeboat does not work on test.	FTF

Table F.1 (continued)

System/ component	Equipment class	Recommended failure definitions	Applicable failure modes ^{a,c,g}
41. Escape, evacuation and rescue (EER): Escape chute release function	Evacuation, escape and rescue	Release/ lowering function for escape chute does not work on test.	FTF
42. Escape, evacuation and rescue (EER): MOB-boat engine, start	Evacuation, escape and rescue	MOB-boat engine does not start when operated.	FTS
a	See Tables B.6 to B.14, and B.15 especially for definitions of abbreviations.		
b	IEC 61508:2010 (all parts) and/or IEC 61511:2016 (all parts) is/are applicable.		
c	Failures can occur upon any demand (both upon test demand as well as upon actual demand).		
d	Leakage; when safe state is closed (valve) and specific safety related leakage rates are specified		
e	Including related HVAC fans where relevant		
f	Leakage testing of DHSV/SCSSV is performed either by: <ul style="list-style-type: none"> • observing and monitoring the pressure build-up in a void/cavity downstream of the valve closing mechanism during the test observation period • by direct measurement of the observed leak rate across the closing mechanism The method used to establish the leak rate should be documented (pressure vs. time relationship or direct measurement). The initial leak rate is the one that should be reported, since the flow rate will be gradually reduced as the pressure below/above the closing mechanism equalizes.		
g	The failure mode INL (Internal leakage) is meant to be internal leakage of utility fluids and needs not be mixed with the failure mode LCP (Leakage in closed position) which involves hydrocarbon leakage through the valve orifice. In case of fail-safe design, INL is not relevant in this table as it will not lead to dangerous failures.		
h	If the gas lift valve acts as a barrier and thus have a barrier function.		

Bibliography

- [1] ISO 2314:2009, *Gas turbines — Acceptance tests*
- [2] ISO 3977 (all parts), *Gas turbines — Procurement*
- [3] ISO 5208:2015, *Industrial valves — Pressure testing of metallic valves*
- [4] ISO 8528-1, *Reciprocating internal combustion engine driven alternating current generating sets — Part 1: Application, ratings and performance*
- [5] ISO 8528-2, *Reciprocating internal combustion engine driven alternating current generating sets — Part 2: Engines*
- [6] ISO 8528-3, *Reciprocating internal combustion engine driven alternating current generating sets — Part 3: Alternating current generators for generating sets*
- [7] ISO 8528-4, *Reciprocating internal combustion engine driven alternating current generating sets — Part 4: Controlgear and switchgear*
- [8] ISO 8528-5, *Reciprocating internal combustion engine driven alternating current generating sets — Part 5: Generating sets*
- [9] ISO 8528-6, *Reciprocating internal combustion engine driven alternating current generating sets — Part 6: Test methods*
- [10] ISO 8528-7, *Reciprocating internal combustion engine driven alternating current generating sets — Part 7: Technical declarations for specification and design*
- [11] ISO 8528-8, *Reciprocating internal combustion engine driven alternating current generating sets — Part 8: Requirements and tests for low-power generating sets*
- [12] ISO 8528-9, *Reciprocating internal combustion engine driven alternating current generating sets — Part 9: Measurement and evaluation of mechanical vibrations*
- [13] ISO 8528-10, *Reciprocating internal combustion engine driven alternating current generating sets — Part 10: Measurement of airborne noise by the enveloping surface method*
- [14] ISO 8528-12, *Reciprocating internal combustion engine driven alternating current generating sets — Part 12: Emergency power supply to safety services*
- [15] ISO 10417:2004, *Petroleum and natural gas industries — Subsurface safety valve systems — Design, installation, operation and redress*
- [16] ISO 10418:1/Cor 1:2008, *Petroleum and natural gas industries — Offshore production installations — Analysis, design, installation and testing of basic surface process safety systems / Technical Corrigendum 1*
- [17] ISO 10423:2009, *Petroleum and natural gas industries — Drilling and production equipment — Wellhead and christmas tree equipment*
- [18] ISO 10432:2004, *Petroleum and natural gas industries — Downhole equipment — Subsurface safety valve equipment*
- [19] ISO 10437:2003, *Petroleum, petrochemical and natural gas industries — Steam turbines — Special-purpose applications*
- [20] ISO 10439-1:2015, *Petroleum, petrochemical and natural gas industries — Axial and centrifugal compressors and expander-compressors — Part 1: General requirements*

- [21] ISO 10439-2:2015, *Petroleum, petrochemical and natural gas industries — Axial and centrifugal compressors and expander-compressors — Part 2: Non-integrally geared centrifugal and axial compressors*
- [22] ISO 10439-3:2015, *Petroleum, petrochemical and natural gas industries — Axial and centrifugal compressors and expander-compressors — Part 3: Integrally geared centrifugal compressors*
- [23] ISO 10439-4:2015, *Petroleum, petrochemical and natural gas industries — Axial and centrifugal compressors and expander-compressors — Part 4: Expander-compressors*
- [24] ISO 10442:2002, *Petroleum, chemical and gas service industries — Packaged, integrally geared centrifugal air compressors*
- [25] ISO 11960:2014, *Petroleum and natural gas industries — Steel pipes for use as casing or tubing for wells*
- [26] ISO 11961:2008, *Petroleum and natural gas industries — Steel drill pipe*
- [27] ISO 12211:2012, *Petroleum, petrochemical and natural gas industries — Spiral plate heat exchangers*
- [28] ISO 12212:2012, *Petroleum, petrochemical and natural gas industries — Hairpin-type heat exchangers*
- [29] ISO/TR 12489:2013, *Petroleum, petrochemical and natural gas industries — Reliability modelling and calculation of safety systems*
- [30] ISO/PAS 12835:2013, *Qualification of casing connections for thermal wells*
- [31] ISO 13053 (all parts):2011, *Quantitative methods in process improvement — Six Sigma*
- [32] ISO 13354:2014, *Petroleum and natural gas industries — Drilling and production equipment — Shallow gas diverter equipment*
- [33] ISO 13623:2009, *Petroleum and natural gas industries — Pipeline transportation systems*
- [34] ISO 13624-1:2009, *Petroleum and natural gas industries — Drilling and production equipment — Part 1: Design and operation of marine drilling riser equipment*
- [35] ISO 13628-1:2005, *Petroleum and natural gas industries — Design and operation of subsea production systems -- Part 1: General requirements and recommendations*
- [36] ISO 13628-4:2010, *Petroleum and natural gas industries — Design and operation of subsea production systems — Part 4: Subsea wellhead and tree equipment*
- [37] ISO 13628-5:2009, *Petroleum and natural gas industries — Design and operation of subsea production systems — Part 5: Subsea umbilicals*
- [38] ISO 13628-7:2005, *Petroleum and natural gas industries — Design and operation of subsea production systems — Part 7: Completion/workover riser systems*
- [39] ISO 13628-15:2011, *Petroleum and natural gas industries — Design and operation of subsea production systems — Part 15: Subsea structures and manifolds*
- [40] ISO 13631:2002, *Petroleum and natural gas industries — Packaged reciprocating gas compressors*
- [41] ISO 13679:2002, *Petroleum and natural gas industries — Procedures for testing casing and tubing connections*
- [42] ISO 13702:2015, *Petroleum and natural gas industries — Control and mitigation of fires and explosions on offshore production installations — Requirements and guidelines*

- [43] ISO 13703:2000, *Petroleum and natural gas industries — Design and installation of piping systems on offshore production platforms*
- [44] ISO 13706:2011, *Petroleum, petrochemical and natural gas industries — Air-cooled heat exchangers*
- [45] ISO 13707:2000, *Petroleum and natural gas industries — Reciprocating compressors*
- [46] ISO 13709:2009, *Centrifugal pumps for petroleum, petrochemical and natural gas industries*
- [47] ISO 13710:2004, *Petroleum, petrochemical and natural gas industries — Reciprocating positive displacement pumps*
- [48] ISO 14001, *Environmental management systems — Requirements with guidance for use*
- [49] ISO 14310:2008, *Petroleum and natural gas industries — Downhole equipment — Packers and bridge plugs*
- [50] ISO 14313:2007, *Petroleum and natural gas industries — Pipeline transportation systems — Pipeline valves*
- [51] ISO 14723:2009, *Petroleum and natural gas industries — Pipeline transportation systems — Subsea pipeline valves*
- [52] ISO 14998:2013, *Petroleum and natural gas industries — Downhole equipment — Completion accessories*
- [53] ISO 15136-1:2009, *Petroleum and natural gas industries — Progressing cavity pump systems for artificial lift — Part 1: Pumps*
- [54] ISO 15138:2007, *Petroleum and natural gas industries — Offshore production installations — Heating, ventilation and air-conditioning*
- [55] ISO 15544:2000, *Petroleum and natural gas industries — Offshore production installations — Requirements and guidelines for emergency response*
- [56] ISO 15547-1:2005, *Petroleum, petrochemical and natural gas industries — Plate-type heat exchangers — Part 1: Plate-and-frame heat exchangers*
- [57] ISO 15547-2:2005, *Petroleum, petrochemical and natural gas industries — Plate-type heat exchangers — Part 2: Brazed aluminium plate-fin heat exchangers*
- [58] ISO 15551-1:2015, *Petroleum and natural gas industries — Drilling and production equipment — Part 1: Electric submersible pump systems for artificial lift*
- [59] ISO 15649:2001, *Petroleum and natural gas industries — Piping*
- [60] ISO 15663-1:2000, *Petroleum and natural gas industries — Life cycle costing — Part 1: Methodology*
- [61] ISO 15663-2:2001, *Petroleum and natural gas industries — Life-cycle costing — Part 2: Guidance on application of methodology and calculation methods*
- [62] ISO 15663-3:2001, *Petroleum and natural gas industries — Life-cycle costing — Part 3: Implementation guidelines*
- [63] ISO 15926 (all parts), *Industrial automation systems and integration — Integration of life-cycle data for process plants including oil and gas production facilities*
- [64] ISO 16070:2005, *Petroleum and natural gas industries — Downhole equipment — Lock mandrels and landing nipples*

- [65] ISO 16530-1:—¹⁾, *Petroleum and natural gas industries — Well integrity — Part 1: Life cycle governance*
- [66] ISO 16708:2006, *Petroleum and natural gas industries — Pipeline transportation systems — Reliability-based limit state methods*
- [67] ISO 16812:2007, *Petroleum, petrochemical and natural gas industries — Shell-and-tube heat exchangers*
- [68] ISO 16904:2016, *Petroleum and natural gas industries — Design and testing of LNG marine transfer arms for conventional onshore terminals*
- [69] ISO 17776:2000²⁾, *Petroleum and natural gas industries — Offshore production installations — Guidelines on tools and techniques for hazard identification and risk assessment*
- [70] ISO 19008:2016, *Standard cost coding system for oil and gas production and processing facilities*
- [71] ISO 19900:2013, *Petroleum and natural gas industries — General requirements for offshore structures*
- [72] ISO 19901-7:2013, *Petroleum and natural gas industries — Specific requirements for offshore structures — Part 7: Stationkeeping systems for floating offshore structures and mobile offshore units*
- [73] ISO 25457:2008, *Petroleum, petrochemical and natural gas industries — Flare details for general refinery and petrochemical service*
- [74] ISO 28300:2008, *Petroleum, petrochemical and natural gas industries — Venting of atmospheric and low-pressure storage tanks*
- [75] ISO 28460:2010, *Petroleum and natural gas industries — Installation and equipment for liquefied natural gas — Ship-to-shore interface and port operations*
- [76] ISO 31000:2009, *Risk management — Principles and guidelines*
- [77] IEC 31010:2009, *Risk management — Risk assessment techniques*
- [78] IEC 60034-1:2004, *Rotating electrical machines — Part 1: Rating and performance*
- [79] IEC 60034-12:2002, *Rotating electrical machines — Part 12: Starting performance of single-speed three-phase cage induction motors*
- [80] IEC 60038:2009, *IEC standard voltages*
- [81] IEC 60050-192:2015, *International electrotechnical vocabulary — Part 192: Dependability*
- [82] IEC 60050-444:2002, *International electrotechnical vocabulary — Part 444: Elementary relays*
- [83] IEC 60076-1:2000, *Power transformers — Part 1: General*
- [84] IEC 60076-2:2011, *Power transformers — Part 2: Temperature rise for liquid-immersed transformers*
- [85] IEC 60076-3:2013, *Power transformers — Part 3: Insulation levels, dielectric tests and external clearances in air*
- [86] IEC 60076-4:2002, *Power transformers — Part 4: Guide to the lightning impulse and switching impulse testing — Power transformers and reactors*
- [87] IEC 60076-5:2006, *Power transformers — Part 5: Ability to withstand short circuit*

1) To be published.

2) Under revision. New title will be *Petroleum and natural gas industries — Offshore production installations — Major Accident hazard management during the design of new installations*.

- [88] IEC 60076-7:2005, *Power transformers — Part 7: Loading guide for oil-immersed power transformers*
- [89] IEC 60076-8:1997, *Power transformers — Part 8: Application guide*
- [90] IEC 60076-10:2001, *Power transformers — Part 10: Determination of sound levels*
- [91] IEC 60076-11:2004, *Power transformers — Part 11: Dry-type transformers*
- [92] IEC 60076-12:2008, *Power transformers — Part 12: Loading guide for dry-type power transformers*
- [93] IEC 60079 (all parts), *Electrical apparatus for explosive gas atmospheres*
- [94] IEC 60085:2007, *Electrical insulation — Thermal evaluation and designation*
- [95] IEC 60146-1:2009, *Semiconductor converters - General requirements and line commutated converters*
- [96] IEC 60227 (all parts), *Polyvinyl chloride insulated cables of rated voltages up to and including 450/750 V*
- [97] IEC 60300-1:2014, *Dependability management — Part 1: Guidance for management and application*
- [98] IEC 60300-2, *Dependability management — Part 2: Dependability programme elements and tasks*
- [99] IEC 60300-3-1, *Dependability management — Part 3: Application guide — Analysis techniques for dependability — Guide on methodology*
- [100] IEC 60300-3-2, *Dependability management — Part 3: Application guide — Collection of dependability data from the field*
- [101] IEC 60300-3-3, *Dependability management — Part 3: Application guide — Life cycle costing*
- [102] IEC 60300-3-4, *Dependability management — Part 3: Application guide — Section 4: Guide to the specification of dependability requirements*
- [103] IEC 60300-3-5, *Dependability management — Part 3-5: Application guide — Reliability test conditions and statistical test principles*
- [104] IEC 60300-3-10, *Dependability management — Part 3-10: Application guide — Maintainability*
- [105] IEC 60300-3-11, *Dependability management — Part 3-11: Application guide — Reliability centred maintenance*
- [106] IEC 60300-3-12, *Dependability management — Part 3-12: Application guide — Integrated logistic support*
- [107] IEC 60300-3-14:2004, *Dependability management — Part 3-14: Application guide - Maintenance and maintenance support*
- [108] IEC 60319, *Presentation and specification of reliability data for electronic components*
- [109] IEC 60381-2, *Analog signals for process control systems — Part 2: Direct voltage signals*
- [110] IEC 60470, *High-voltage alternating current contactors and contactor-based motor-starters*
- [111] IEC 60502, *Power cables with extruded insulation and their accessories for rated voltages from 1 kV ($U_m = 1,2$ kV) up to 30 kV ($U_m = 36$ kV)*
- [112] IEC 60529:2001, *Degrees of protection provided by enclosures (IP Code)*
- [113] IEC 60605-4, *Equipment reliability testing — Part 4: Statistical procedures for exponential distribution — Point estimates, confidence intervals, prediction intervals and tolerance intervals*

- [114] IEC 60605-6, *Equipment reliability testing — Part 6: Test for the validity of the constant failure rate or constant failure intensity assumptions*
- [115] IEC 60706-2, *Guide on maintainability of equipment — Part 2: Maintainability studies during the design phase*
- [116] IEC 60706-3, *Guide on maintainability of equipment — Part 3: Verification and collection, analysis and presentation of data*
- [117] IEC 60706-5, *Guide on maintainability of equipment — Part 5: Diagnostic testing*
- [118] IEC 60812, *Analysis techniques for system reliability — Procedure for failure mode and effects analysis (FMEA)*
- [119] IEC 60840:2011, *Power cables with extruded insulation and their accessories for rated voltages above 30 kV ($U_m = 36$ kV) up to 150 kV ($U_m = 170$ kV) — Test methods and requirement*
- [120] IEC 60947-2:2006, *Low-voltage switchgear and controlgear — Part 2: Circuit-breakers*
- [121] IEC 60947-3:2008, *Low-voltage switchgear and controlgear — Part 3: Switches, disconnectors, switch-disconnectors and fuse-combination units*
- [122] IEC 60947-4-1:2009, *Low-voltage switchgear and controlgear — Part 4-1: Contactors and motor-starters — Electromechanical contactors and motor-starters*
- [123] IEC 61000-4-7:2002, *Electromagnetic compatibility (EMC) — Part 4-7: Testing and measurement techniques — General guide on harmonics and interharmonics measurements and instrumentation, for power supply systems and equipment connected thereto*
- [124] IEC 61025:2006, *Fault tree analysis (FTA)*
- [125] IEC 61070:1991, *Compliance test procedures for steady-state availability*
- [126] IEC 61078:2016, *Reliability block diagrams*
- [127] IEC 61123:1991, *Reliability testing — Compliance test plans for success ratio*
- [128] IEC 61124:2012, *Reliability testing — Compliance tests for constant failure rate and constant failure intensity*
- [129] IEC 61131, *Programmable controllers*
- [130] IEC 61163-1:2006, *Reliability stress screening - Part 1: Repairable assemblies manufactured in lots*
- [131] IEC 61164:2004, *Reliability growth — Statistical test and estimation methods*
- [132] IEC 61165:2006, *Application of Markov techniques*
- [133] IEC 61439-1, *Low-voltage switchgear and controlgear assemblies — Part 1: General rules*
- [134] IEC/TR 61508-0:2005, *Functional safety of electrical/electronic/programmable electronic safety-related systems - Part 0: Functional safety and IEC 61508*
- [135] IEC 61508-1:2010, *Functional safety of electrical/electronic/programmable electronic safety-related systems - Part 1: General requirements*
- [136] IEC 61508-2:2010, *Functional safety of electrical/electronic/programmable electronic safety-related systems - Part 2: Requirements for electrical/electronic/programmable electronic safety-related systems*
- [137] IEC 61508-3:2010, *Functional safety of electrical/electronic/programmable electronic safety-related systems - Part 3: Software requirements*

- [138] IEC 61508-4:2010, *Functional safety of electrical/electronic/programmable electronic safety-related systems - Part 4: Definitions and abbreviations*
- [139] IEC 61508-5:2010, *Functional safety of electrical/electronic/programmable electronic safety-related systems - Part 5: Examples of methods for the determination of safety integrity levels*
- [140] IEC 61508-6:2010, *Functional safety of electrical/electronic/programmable electronic safety-related systems - Part 6: Guidelines on the application of IEC 61508-2 and IEC 61508-3*
- [141] IEC 61508-7:2010, *Functional safety of electrical/electronic/programmable electronic safety-related systems - Part 7: Overview of techniques and measures*
- [142] IEC 61511-1:2016, *Functional safety — Safety instrumented systems for the process industry sector — Part 1: Framework, definitions, system, hardware and software requirements*
- [143] IEC 61511-2:2016, *Functional safety — Safety instrumented systems for the process industry sector — Part 2: Guidelines for the application of IEC 61511-1*
- [144] IEC 61511-3:2016, *Functional safety - Safety instrumented systems for the process industry sector - Part 3: Guidance for the determination of the required safety integrity levels*
- [145] IEC 61649:1997, *Goodness-of-fit tests, confidence intervals and lower confidence limits for Weibull distributed data*
- [146] IEC 61650:1997, *Reliability data analysis techniques — Procedures for comparison of two constant failure rates and two constant failure (event) intensities*
- [147] IEC 61703:2016, *Mathematical expressions for reliability, availability, maintainability and maintenance support terms*
- [148] IEC 61709:2011, *Electric components — Reliability - Reference conditions for failure rates and stress models for conversion*
- [149] IEC 61800-1:1997, *Adjustable speed electrical power drive systems — Part 1: General requirements - Rating specifications for low voltage adjustable speed d.c. power drive systems*
- [150] IEC 61800-2:2015, *Adjustable Speed Electrical Power Drive Systems — Part 2: General requirements — Rating specifications for low voltage adjustable frequency a.c. power drive systems*
- [151] IEC 61800-3:2004, *Adjustable speed electrical power drive systems — Part 3: EMC requirements and specific test methods*
- [152] IEC 61800-4:2002, *Adjustable Speed Electrical Power Drive Systems — Part 4: General requirements — Rating specifications for a.c. power drive systems above 1000V a.c. and not exceeding 35 kV*
- [153] IEC 61800-5-1:2007, *Adjustable speed electrical power drive systems — Part 5-1: Safety requirements — Electrical, thermal and energy*
- [154] IEC 61810-2: 2011, *Electromechanical elementary relays — Part 2: Reliability*
- [155] IEC 62040-2:2005, *Uninterruptible power systems (UPS) — Part 2: Electromagnetic compatibility (EMC) requirements*
- [156] IEC 62040-3:2011, *Uninterruptible power systems (UPS) — Part 3: Method of specifying the performance and test requirements*
- [157] IEC 62114³⁾, *Electrical insulation - Thermal evaluation and designation*
- [158] IEC 62271-1:2007, *High-voltage switchgear and controlgear — Part 1: Common specifications*

3) Withdrawn (replaced by IEC 60085).

- [159] IEC 62271-100:2008, *High-voltage switchgear and controlgear — Part 100: Alternating current circuit-breakers*
- [160] IEC 62271-102:2001, *High-voltage switchgear and controlgear — Part 102: Alternating current disconnectors and earthing switches*
- [161] IEC 62271-200:2011, *High-voltage switchgear and controlgear — Part 200: AC metal-enclosed switchgear and controlgear for rated voltages above 1 kV and up to and including 52 kV*
- [162] IEC 62508:2010, *Guidance on human aspects of dependability*
- [163] IEC 62551: 2012, *Analysis techniques for dependability — Petri net techniques*
- [164] IEC 62740: 2015, *Root cause analysis (RCA)*
- [165] EN 13306:2010, *Maintenance — Maintenance terminology*
- [166] API RP 7C-11F, *Recommended Practice for Installation, Maintenance, and Operation of Internal-Combustion Engines*
- [167] API RP 11S, *Recommended Practice for the Operation, Maintenance and Troubleshooting of Electric Submersible Pump Installations*
- [168] API RP 14B, *Design, Installation, Repair and Operation of Subsurface Safety Valve Systems, Sixth Edition*
- [169] API RP 17B, *Recommended Practice for Flexible Pipe, Fifth Edition (May 2014)*
- [170] API RP 17H, *Remotely Operated Tools and Interfaces on Subsea Production Systems, Second Edition, 2013*
- [171] API RP 554, *Part 1, API Recommended Practice 554, Part 2: Process Control Systems — Process Control Systems Functions and Functional Specification Development, Second Edition*
- [172] API RP 554, *Part 2, API Recommended Practice 554, Part 2: Process Control Systems — Process Control System Design, First Edition*
- [173] API RP 554, *Part 3, API Recommended Practice 554, Part 3: Process Control Systems — Project Execution and Process Control System Ownership, First Edition*
- [174] API RP 580, *Risk-Based Inspection, Second Edition*
- [175] SPEC API 5CT, *Specification for Casing and Tubing*
- [176] SPEC API 6A, *Specification for Wellhead and Christmas Tree Equipment, Twentieth Edition (ISO 10423:2009 Modification), Includes Errata (through Errata 7, December 2014), Addenda 1(Nov 2011), 2 (Nov 2012), 3 (March 2013)*
- [177] SPEC API 6D, *Specification for Pipeline and Piping Valves, Twenty-Fourth Edition (2014), includes Errata 1 (2014), Errata 2 (2014), Errata 3 (2015), and Addendum 1 (2015), Errata 5 (2015), Errata 6 (2015), Errata 7 (2016), and Addendum 2 (2016)*
- [178] SPEC API 7B-11C, *Specification for Internal-Combustion Reciprocating Engines for Oil Field Service*
- [179] SPEC API 12D, *Specification for Field Welded Tanks for Storage of Production Liquids*
- [180] SPEC API 12F, *Specification for Shop Welded Tanks for Storage of Production Liquids, Twelfth Edition*
- [181] SPEC API 12P, *Specification for Fiberglass Reinforced Plastic Tanks, Third Edition*
- [182] SPEC API 14A, *Specification for Subsurface Safety Valve Equipment, Twelfth Edition, Includes Errata (July, 2015)*

ISO 14224:2016(E)

- [183] SPEC API 14L, Specification for Lock Mandrels and Landing Nipples, Second Edition
- [184] SPEC API 16A, Specification for Drill Through Equipment. Includes Errata, Third Edition (2004)
- [185] SPEC API 16D, Specification for Control Systems for Drilling Well Control Equipment and Control Systems for Diverter Equipment Second Edition
- [186] SPEC API 17J, Specification for Unbonded Flexible Pipe, Fourth Edition (May 2014)
- [187] SPEC API 19G2, Flow-control devices for side-pocket mandrels, twelfth Edition
- [188] API/Std 17F, Standard for Subsea Production Control Systems, Third Edition
- [189] API/Std 53, *Blowout Prevention Equipment Systems for Drilling Wells, Fourth Edition*
- [190] API/Std 520, *Part 1, Sizing, Selection, and Installation of Pressure-relieving Devices, Part I - Sizing and Selection, Ninth Edition*
- [191] API/Std 520, *Part 2, Sizing, Selection, and Installation of Pressure-Relieving Devices in Refineries- Part II, Installation, Sixth Edition*
- [192] API/Std 521, *Pressure-relieving and Depressuring Systems, Sixth Edition (2014)*
- [193] API/Std 526, *Flanged Steel Pressure-relief Valves, Sixth Edition (Includes Errata 1, Errata 2)*
- [194] API/Std 537, *Flare Details for General Refinery and Petrochemical Service, Second Edition (ISO 25457:2008, Identical)*
- [195] API/Std 537, *Datasheets, Datasheets for API 537, Second Edition*
- [196] API/Std 541, *Form-wound Squirrel-Cage Induction Motors-500 Horsepower and Larger, Fifth Edition*
- [197] API/Std 541, *Datasheets, Data sheets for API Std 541*
- [198] API/Std 547, *General-Purpose Form-Wound Squirrel Cage Induction Motors 250 Horsepower and Larger - First Edition*
- [199] API/Std 547, *Datasheets, Datasheets for API Standard 547, General-Purpose Form Wound Squirrel Cage Induction Motors - 250 Horsepower and Larger*
- [200] API/Std 560, *Fired Heaters for General Refinery Service, Fourth Edition*
- [201] API/Std 560, *Datasheets, Datasheets for Fired Heaters for General Refinery Services*
- [202] API/Std 594, *Check Valves: Flanged, Lug, Wafer and Butt-welding*
- [203] API/Std 609, *Butterfly Valves: Double-flanged, Lug- and Wafer-type*
- [204] API/Std 610, *Centrifugal Pumps for Petroleum, Petrochemical and Natural Gas Industries, Eleventh Edition (ISO 13709:2009 Identical Adoption), Includes Errata (July 2011)*
- [205] API/Std 610 *Datasheets, Datasheets for Centrifugal Pumps for Petroleum, Petrochemical and Natural Gas Industries, Eleventh Edition*
- [206] API/Std 611, *Datasheets, Datasheets for API Std 611, Fifth Edition*
- [207] API/Std 611, *Datasheets, Datasheets for Centrifugal Pumps for Petroleum, Petrochemical and Natural Gas Industries, Eleventh Edition*
- [208] API/Std 612, *Petroleum, Petrochemical and Natural Gas Industries-Steam Turbines-Special-purpose Applications, Seventh Edition*
- [209] API/Std 612, *Datasheets, Datasheets for API Std 612*

- [210] API/Std 616, *Gas Turbines for the Petroleum, Chemical, and Gas Industry Services, Fifth Edition*
- [211] API/Std 616, *Datasheets, Datasheets for API Standard 616, Gas Turbines for the Petroleum, Chemical, and Gas Industry Services*
- [212] API/Std 617, *Axial and Centrifugal Compressors and Expander-compressors, Eighth Edition*
- [213] API/Std 617, *Datasheets, Datasheets for API Standard 617, Axial and Centrifugal Compressors and Expander-compressors, Eighth Edition*
- [214] API/Std 618, *Reciprocating Compressors for Petroleum, Chemical, and Gas Industry Services, Fifth Edition, Includes Errata 1 and 2 (2009 and 2010)*
- [215] API/Std 618, *Datasheets, Datasheets for use with Std 618, Fifth Edition, Includes Errata (2009)*
- [216] API/Std 619, *Rotary-Type Positive-Displacement Compressors for Petroleum, Petrochemical, and Natural Gas Industries, Fifth Edition*
- [217] API/Std 619, *Datasheets, Datasheets for API Std 619*
- [218] API/Std 620, *Design and Construction of Large, Welded, Low-Pressure Storage Tanks, Twelfth Edition*
- [219] API/Std 650, *Welded Tanks for Oil Storage, Twelfth Edition, Includes Errata 1 (2013), Errata 2 (2014), and Addendum 1 (2014)*
- [220] API/Std 650, *Datasheets, Datasheets for API 650, Welded Steel Tanks for Oil Storage, 12th Edition*
- [221] API/Std 660, *Shell-and-tube Heat Exchangers, Ninth Edition*
- [222] API/Std 660, *Datasheets, Datasheets API Std 660*
- [223] API/Std 661, *Petroleum, Petrochemical, and Natural Gas Industries - Air-cooled Heat Exchangers, Seventh Edition*
- [224] API/Std 661, *Datasheets, Datasheets for Air-Cooled Heat Exchangers for General Refinery Services, Sixth Edition - Adoption of ISO 13706-1:2005*
- [225] API/Std 662, *Part 1, Plate Heat Exchangers for General Refinery Services - Part 1 - Plate-and-Frame Heat Exchangers, First Edition - ISO Adoption from ISO 15547-1:2005*
- [226] API/Std 662, *Part 2, Plate Heat Exchangers for General Refinery Services - Part 2 - Brazed Aluminum Plate-fin Heat Exchangers First Edition - ISO Adoption from ISO 15547-2:2005*
- [227] API/Std 662, *Datasheets, Datasheets for Plate Heat Exchangers for General Refinery Services, Second Edition*
- [228] API/Std 673, *Centrifugal Fans for Petroleum, Chemical and Gas Industry Services, Third Edition*
- [229] API/Std 673, *Datasheets, Datasheets for Centrifugal Fans for Petroleum, Chemical and Gas Industry Services, 3rd Edition*
- [230] API/Std 674, *Positive Displacement Pumps - Reciprocating, Includes Errata (May 2014), Errata 2 (April 2015)*
- [231] API/Std 674, *Datasheets, Datasheets for Positive Displacement Pumps - Reciprocating*
- [232] API/Std 676, *Positive Displacement Pumps-Rotary, Third Edition*
- [233] API/Std 676, *Datasheets, Datasheets for Positive Displacement Pumps – Rotary*
- [234] API/Std 2000, *Venting Atmospheric and Low-pressure Storage Tanks. Seventh Edition*
- [235] API/Std 2610, *Design, Construction, Operation, Maintenance, and Inspection of Terminal & Tank Facilities, Second Edition*

- [236] NORSOK C-004:2013, *Helicopter deck on offshore installations*
- [237] NORSOK D-002:2013, *Well intervention equipment, Revision 2*
- [238] NORSOK D-010:2013, *Well integrity in drilling and well operations*
- [239] NORSOK I-001:2010, *Field instrumentation*
- [240] NORSOK N-001:2012, *Integrity of offshore structures*
- [241] NORSOK R-002:2012, *Lifting equipment*
- [242] NORSOK S-001:2008, *Technical safety*
- [243] NORSOK T-001:2010, *Telecom systems*
- [244] NORSOK T-100:2010, *Telecom subsystems*
- [245] NORSOK U-100:2015, *Manned underwater operations*
- [246] NORSOK Z-008: 2011, *Risk based maintenance and consequence classification*
- [247] NORSOK Z-013:2010, *Risk and emergency preparedness assessment*
- [248] DNV OS-F101:2013, *Submarine Pipeline Systems*
- [249] DNV RP-F116:2015, *Integrity Management of Submarine Pipeline Systems*
- [250] DNV-OS-E406:2010, *Design of Free Fall Lifeboats*
- [251] ASME B31.3-2014, *Process Piping*
- [252] ASME B16.34-2013, *Valves - Flanged, Threaded and Welding End*
- [253] ASME: BPVC Section VIII-Rules for Construction of Pressure Vessels Division 1
- [254] ASME: BPVC Section VIII-Rules for Construction of Pressure Vessels Division 2 - Alternative Rules
- [255] BS 4778-3.1:1991, *Quality vocabulary. Availability, reliability and maintainability terms. Guide to concepts and related definitions*
- [256] BS 4999-140:1987, *General requirements for rotating electrical machines Part 140. Voltage regulation and parallel operation of A.C. synchronous generators*
- [257] CAN/CSA C88-M, *Power Transformers and Reactors*
- [258] CSA FT4, *Vertical Flame Test — Cables in Cable Trays*
- [259] CAN/CSA C68.3-97, *Shielded and Concentric Neutral Power Cables Rated 5-46 kV (Includes GI #2, #3, and Updates #4 and #5)*
- [260] FCC 47CFR15, *Utility-Type Battery Chargers NEMA PE 5 Radio Frequency Devices*
- [261] ICEA S-93-639-2000, *International safety guide for oil tankers and terminals Quality management and quality assurance standards, Part1 – Part 4 ISO 9000 series 5-46 kV shielded power cable for use in the transmission and distribution of electric energy*
- [262] IEEE 1202-2006, *IEEE Standard for Flame-Propagation Testing of Wire & Cable*
- [263] IEEE C37.012-2014, *IEEE Guide for the Application of Capacitance Current Switching for AC High-Voltage Circuit Breakers Above 1000 V*
- [264] IEEE C37.101-2006, *IEEE Guide for Generator Ground Protection*
- [265] IEEE C37.102-2007, *IEEE Guide for AC Generator Protection*

- [266] IEEE C37.13.1-2006, *IEEE Standard for Definite Purpose Switching Devices for Use in Metal-Enclosed Low-Voltage Power Circuit Breaker Switchgear*
- [267] IEEE C37.20.7-2007, *IEEE Guide for Testing Metal-Enclosed Switchgear Rated Up to 38 kV for Internal Arcing Faults*
- [268] IEEE C37.20.7-2007/Cor 1-2010, *IEEE Guide for Testing Metal-Enclosed Switchgear Rated up to 38 kV for Internal Arcing Faults Corrigendum 1*
- [269] IEEE C57.12.10-2010, *IEEE Standard Requirements for Liquid-Immersed Power Transformers*
- [270] IEEE 1566-2005, *IEEE Standard for Performance of Adjustable Speed AC Drives Rated 375 kW and Larger*
- [271] IEEE C57.18.10-1998, *IEEE Standard Practices and Requirements for Semiconductor Power Rectifier Transformers*
- [272] NEMA 20C, *Cable tray systems*
- [273] NEMA MG 1, *Motors and generators*
- [274] NEMA PE 1, *Uninterruptible Power Systems (UPS) — Specification and Performance Verification*
- [275] NEMA PE 5, *Utility Type Battery Chargers*
- [276] NEMA PE 7, *Communication Type Battery Chargers*
- [277] NEMA VE-1, *Metal cable tray systems*
- [278] NEMA VE-2, *Cable tray installation guidelines*
- [279] NFPA 13: *Standard for the Installation of Sprinkler Systems. National Fire Protection Association, NFPA.*
- [280] NFPA 15: *Standard for Water Spray Fixed Systems for Fire Protection. National Fire Protection Association, NFPA.*
- [281] NFPA 16: *Standard for the Installation of Foam-Water Sprinkler and Foam-Water Spray Systems. National Fire Protection Association, NFPA.*
- [282] UL 1072, *UL standard for safety medium-voltage power cables*
- [283] UL 1277, *UL standard for safety electrical power and control tray cables with optional optical-fiber members*
- [284] UL 1569, *UL standard for safety metal-clad cables*
- [285] UL 2225, *UL standard for safety cables and cable-fittings for use in hazardous (classified) locations*
- [286] UL 2250, *UL standard for safety instrumentation tray cable*
- [287] IMO/COMSAR/Circ.32, *Harmonization of GMDSS requirements for radio installations on board SOLAS ships, 2004*
- [288] IMO. SOLAS. *International Convention for the Safety of Life at Sea (SOLAS), 1974*
- [289] IMO, SOLAS. MSC.48 (66): *Life saving appliances code, 2010.*
- [290] IMO, SOLAS. MSC.81 (70): *Testing and evaluation of life saving appliances, 2010.*
- [291] MIL-STD-1629A, *Procedures for performing FMEA-analysis, 1980*
- [292] SAE JA1011:1999, *Evaluation Criteria for RCM Processes*

- [293] SAE JA1012:2002, *A Guide to the Reliability Centered Maintenance (RCM) Standard*
- [294] ASCHER H., & FEINGOLD H. *Repairable Systems Reliability*. Marcel Dekker, New York, 1984
- [295] COOKE R.M. *Experts in Uncertainty: Expert Opinion and Subjective Probability in Science*. Oxford University Press, 1992
- [296] GEORGIN J.P., & SIGNORET J.P. The maximum likelihood estimate from a confidence level point of view – Proposition for an improved one. *Reliab. Eng.* 1981, **2** pp. 259–269
- [297] HERNU M. Using benchmark data effectively, NPRA Maintenance conference May 2000 (Austin TX)
- [298] KIRWAN B. *A guide to practical human reliability assessment*. Taylor & Francis, UK, 1994
- [299] MARTZ H.F., & WALLER R.A. *Bayesian Reliability and Analysis*. John Wiley & Sons, 1982
- [300] MOORE-EDE M. *The definition of human fatigue, white paper*, Circadian Information Limited Partnership, 2009.
- [301] NPRA Maintenance Conference 2002, Identifying and implementing improvement opportunities, through benchmarking, Workshop MC-02-88
- [302] OREDA® (Offshore and Onshore Reliability Data): Joint oil and gas industry project for collection of equipment reliability and maintenance data
- [303] REASON J. *Human Error*. Cambridge University Press, UK, 1990
- [304] SELVIK J.T., & AVEN T. A framework for reliability and risk centered maintenance. *Reliab. Eng. Syst. Saf.* 2011, **96** (2) pp. 324–331
- [305] SEVESO III directive: The European Parliament and the Council of the European Union, Directive 2012/18/EU of the European Parliament and the Council of 4 July 2012 on the control of major-accident hazards involving dangerous substances, amending and subsequently repealing Council Directive 96/82/EC.
- [306] SINTEF and NTNU, *Offshore and Onshore Reliability Data Handbook, Volume I & II*, ed. 6, April 2015
- [307] The Norwegian Oil and Gas Association, 070 - Norwegian Oil and Gas Recommended Guidelines for Application of IEC 61508 and IEC 61511 in the Norwegian Petroleum Industry, Draft version, 26 Feb 2016
- [308] VAN NOORTWIJK J.M., DEKKER R., COOKE M., MAZZUCCHI T.A. Expert judgment in maintenance optimization. *IEEE Trans. Reliab.* 1992, **41** (3) pp. 427–432
- [309] WELLMASTER®: Joint oil and gas industry project for collection of well completion reliability and maintenance data

